

Panasonic®

**Building Passion,
Building Solutions.**
Panasonic Air Conditioning Systems

We face a time in which "quality air" differentiates business. It's a time for Panasonic to fully display its strengths. Our ability to assemble and build superior systems isn't just due to the rich resources we have as a comprehensive electronics manufacturer, but also to Panasonic's 100 years of tradition, where each person thinks and acts on their own initiative while working in a team to reach further heights. We do not compromise. Each of our independent selves is a one stop solution. We face our customers' challenges together with our customers and do all that we can to build effective systems. As a true partner for our customers, we strive to always be at the forefront of business.

- Please read the Installation Instructions carefully before installing the unit, and the Operating Instructions before using it.
- Specifications are subject to change without prior notice.
- The contents of this catalogue are accurate as of March 2021.
- Due to printing considerations, actual colours may vary slightly from those shown.
- All graphics are provided solely for the purpose of illustrating a point.



Do not add or replace refrigerant other than the specified type. Manufacturer is not responsible for damage or deterioration in safety due to usage of other refrigerant.

Authorised Dealer

FSV Mini FSV ASIA GENERAL_MARCH_2021

FSV VRF SYSTEMS 2021/2022



Residential &
Light Commercial Use



Commercial Use



A Better Life, A Better World



Panasonic Heating & Cooling Solutions

Global site : aircon.panasonic.com
PRO Club : panasonicproclub.global



[airconpanasonicglobal](https://www.youtube.com/channel/UCaRn3p1p1p1p1p1p1p1p1p1)

QUALITY AIR FOR LIFE

THE GAME CHANGER



ALL INVERTER

VRF with Extraordinary Energy-Saving Performance and Powerful Operation

EER 5.3 (U-8ME2H7)

A game-changing VRF system delivering energy-saving performance, powerful operation, reliability and comfort surpassing anything previously possible.

It represents a true paradigm shift in air conditioning solutions. Taking quality to the extreme — that's the Panasonic challenge.



Multiple large-capacity all inverter compressors (more than 14HP)

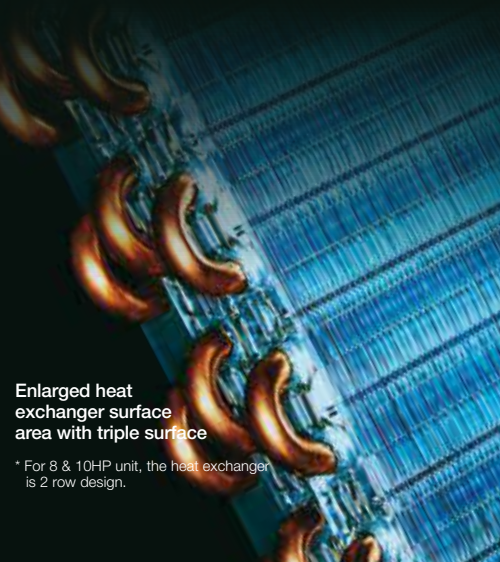

Enlarged heat exchanger surface area with triple surface

* For 8 & 10HP unit, the heat exchanger is 2 row design.



Newly designed curved air discharge bell mouth for better aerodynamics

Panasonic
FSV EX
INVERTER

Extraordinary

5.3
EER

In the case of U-8ME 2H7

CONTENTS

| | | |
|---|---|--|
| 02 FSV-EX Introduction | 60 Indoor Units | 102 R1 Type / Concealed Floor Standing |
| 04 Mini-FSV Introduction | 62 FSV Indoor Units Range | 104 Remark for High Static Ducted Series |
| 06 FSV-EX Advantages | 64 F3 Type / Mid Static Adaptive Ducted | 106 FSV Controllers |
| 08 FSV-EX Series / Exclusive Feature 1 Extended Operation Range | 68 F2 Type / Mid Static Ducted | 109 Individual Control Systems |
| 10 FSV-EX Series / Exclusive Feature 2 Energy-Saving Performance | 72 M1 Type / Slim Low Static Ducted | 111 Timer Operation |
| 12 FSV-EX Series / Exclusive Feature 3 Oil Management System | 74 Z1 Type / Slim Low Static Ducted Twenty Series | 112 Centralised Control Systems |
| 14 ECONAVI | 76 E2 Type / High Static Ducted | 116 P-AIMS |
| 16 Exclusive Feature / High-spec Wired Remote Controller | 78 E2 Type / Energy Saving High Fresh Air Ducted | 118 T10 Terminal for External Control |
| 20 Exclusive Feature / Air Handling Unit Kit | 80 E1 Type / High Static Ducted | 119 Interfaces for External Control |
| 24 Exclusive Feature / Design Support Software for FSV | 82 H1 Type / High-Fresh Air Ducted | 120 Serial Interface for 3rd Party External Controller |
| 26 FSV Systems | 84 K2 Type / Wall Mounted | 121 Serial Interface for LonWorks Network |
| 28 2-WAY FSV-EX ME2 Series | 88 U2 Type / 4-Way Cassette | 122 FSV Controller External Dimensions |
| 44 2-WAY Mini-FSV LE Series | 92 Y2 Type / 4-Way Mini Cassette | 124 VRF Renewal |
| 54 nanoe™ X | 94 L1 Type / 2-Way Cassette | 128 A Globally Trusted Air Conditioning Brand |
| | 96 D1 Type / 1-Way Cassette | 130 Reliability and Durability |
| | 98 T2 Type / Ceiling Mounted | 132 Global Networking of Air Conditioning Solutions |
| | 100 P1 Type / Floor Standing | 134 Panasonic VRF Global Project References |

MINI GAME CHANGER

LE1 Series
4.20^{*}
EER
* In the case of 8HP



Mini VRF LE Series

Cooling & Heating Type 8/10 HP [LE1] 4/5/6 HP [LE2]

Mini-FSV with Extraordinary Energy-Saving Performance and High External Static Pressure(35Pa)



High External Static
Pressure 35Pa

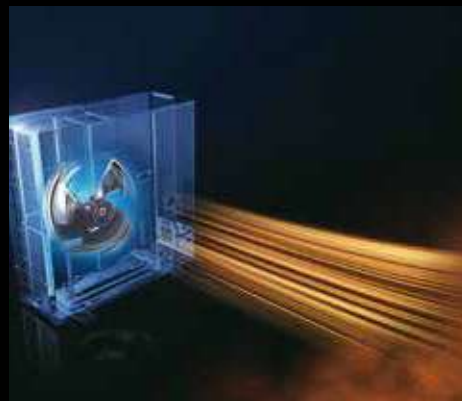

Compact Design



Long Piping Design
Length for Greater
Design Flexibility

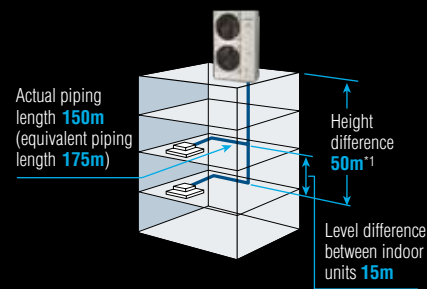

LE1 Max. total piping length: **300m**
LE2 Max. total piping length: **180m**

*1: 40m if the outdoor unit is below the indoor unit.

LE2 Series
5.08^{*}
EER
* In the case of 4HP

FSV-EX Advantages



The most efficient, powerful and quiet system in Panasonic's history. There has never been a VRF system like it. It's the story of a true game changer.

Extraordinary Energy-Saving Performance

The FSV-EX marks a revolutionary step forward in VRF efficiency. A look at the incredible EER value clearly indicates that. What's more, this high EER value is achieved even during part load operation. This shows the extraordinary energy-saving performance the FSV-EX is capable of providing.

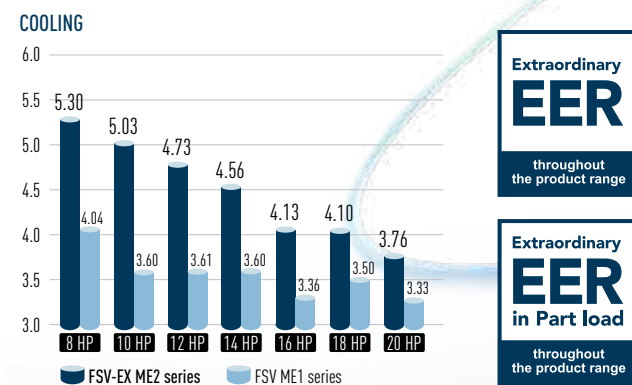

Low-Noise Operation

Numerous technological innovations, including an improved compressor and a newly designed bell mouth and larger fan, have dramatically reduced the outdoor noise level. The result is an even more comfortable building environment.

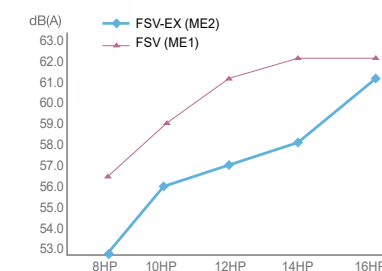

Multiple large-capacity all inverter compressors

(more than 14HP)

Two independently controlled inverter compressors achieve high efficiency. Redesigned components in the body provide performance improvement especially in the rated cooling condition and EER performance.



Extended Operation Range Up to 52°C

The FSV-EX can provide cooling even when the outside temperature reaches a maximum of about 52°C. And amazingly, it can still operate at 100% capacity when the outside temperature is as high as 43°C. This high power capability enables reliable operation even under extremely high temperature conditions.

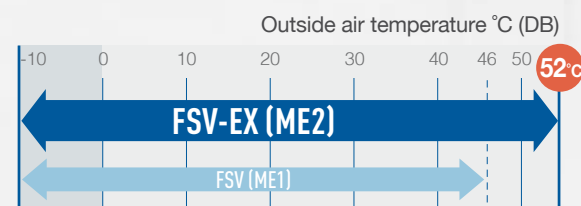

Enlarged heat exchanger surface area with triple surface*

The new heat exchanger features a triple-surface construction. Compared to the divided dual-surface construction in current models, there is no division of space and the area for heat exchange is larger. Also, highly efficient piping pattern increases heat exchange performance by 5%.



* For 8 & 10HP unit, the heat exchanger is 2 row design.

Extended Operation Range up to 52°C



High reliability even under high temperature conditions

Designed to be durable enough to withstand extreme heat, FSV EX ensures reliable cooling operation over an extended operation range up to 52°C.

OPERATING RANGE

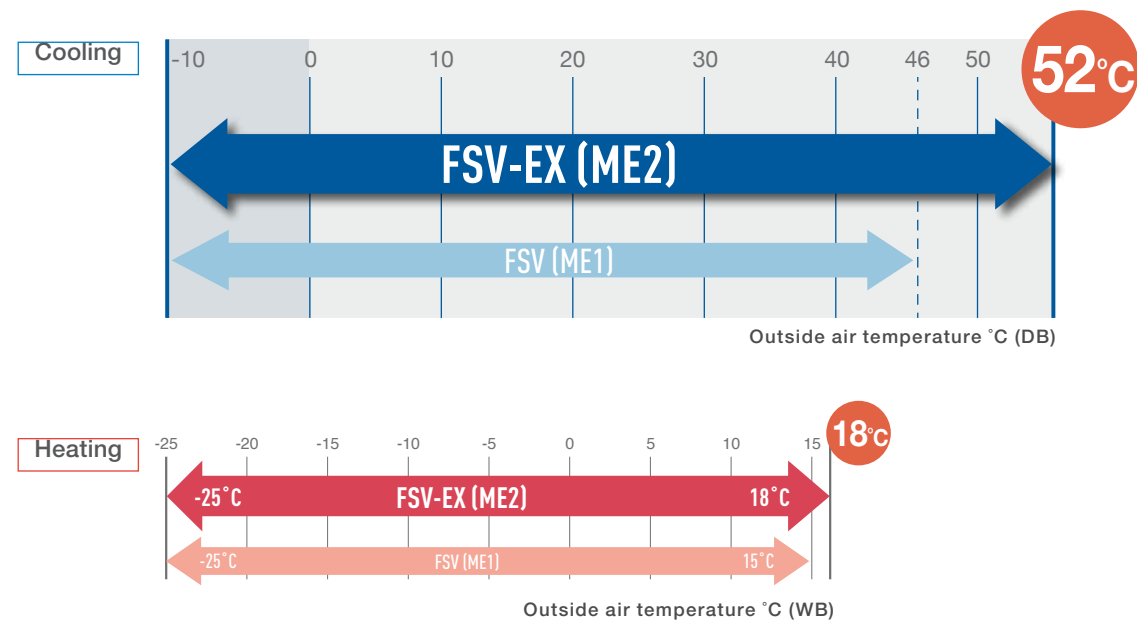

Full-capacity Operation up to 43°C

The FSV-EX can provide cooling even when the outside temperature reaches a maximum of about 52°C. And amazingly, it can still operate at 100% capacity when the outside temperature is as high as 43°C. This high power capability enables reliable operation even under extremely high temperature conditions.

CAPACITY RATIO (COOLING)

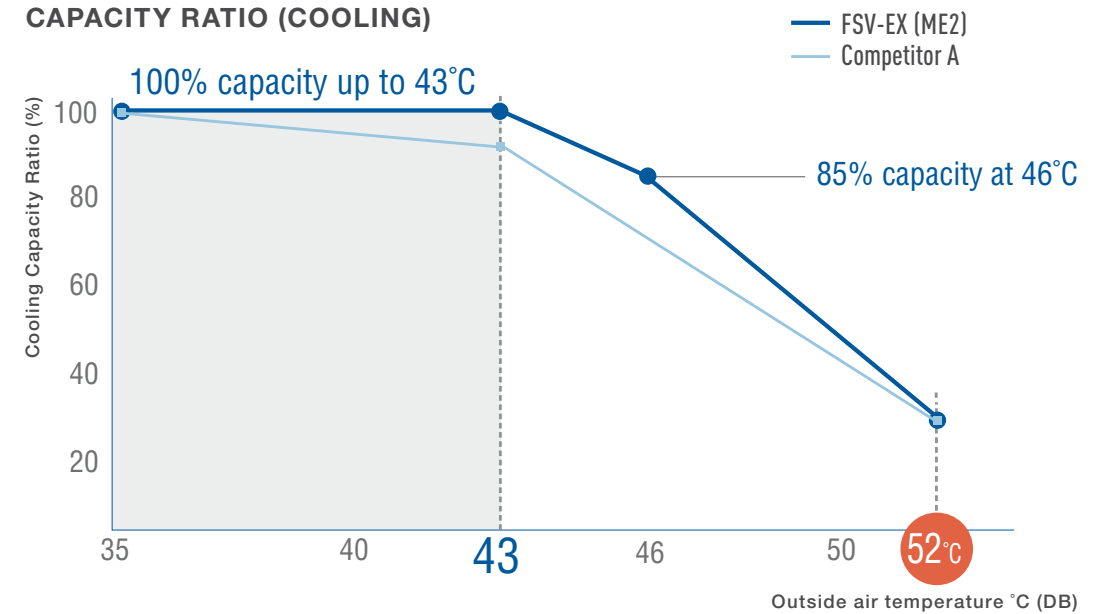

<Test Condition> 12HP model, IU/OU capacity ratio:100%, Indoor Condition:27°C[DB]/19°C[WB]
Competitor A spec is from technical data book.



Extraordinary Energy-Saving Performance



Practical Design for Actual Operation

Panasonic builds air conditioning systems not only with a high EER for rated operation, but also with Seasonal-EER appropriate to the customer's actual environment of use. For instance, with rated operation, outdoor temperature is constant at 35°C, but in reality the outdoor temperature is continuously changing. Consequently, required air conditioning performance also changes. That's why Panasonic implements the following kind of proprietary control.

1. Set temperature is rapidly attained; full-load operating time is kept to a minimum.
2. The frequency of forced oil recovery is minimised. The volume of oil within the compressors is monitored precisely by sensors, so forced oil recovery under full-load operation is conducted only when necessary. Since this suppresses noise due to oil recovery, comfort is maintained.
3. Panasonic pursues a high EER, of course, as well as high EER in part load, for energy saving performance under a broad range of loads.

Panasonic's design concept contributes to substantial energy cost reductions.

Rapidly reaches set temperature
→ full-load operation duration minimised

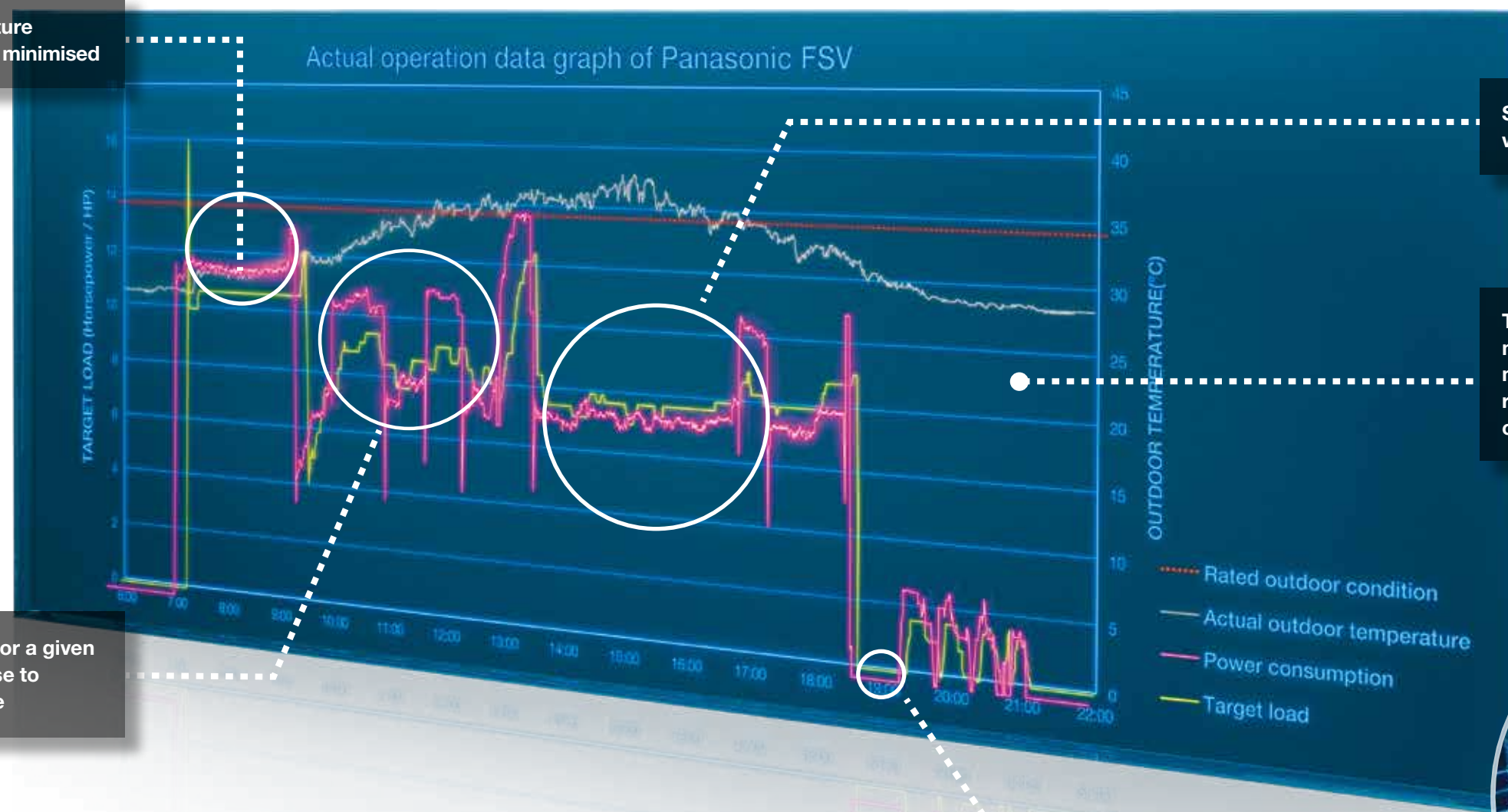

Set temperature maintained with minimum load operation

Thanks to superior oil management, oil recovery is minimised, contributing to reduced energy use and costs

Load increased as required for a given outdoor temperature increase to maintain the set temperature

When outdoor temperature drops, operation is immediately stopped

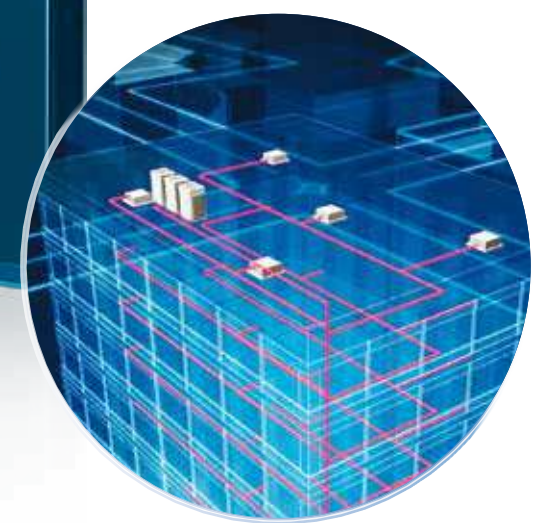

Actual performance data of Panasonic FSV installed in Asia

Simulated conditions
Location: Panasonic building in Malaysia System: One 16HP outdoor unit, 4 cassette-type indoor units

Intelligent 3-stage Oil Management System



In a VRF system, where lengthy piping and a large number of indoor units need to be controlled collectively, the key to maintaining the system's reliability is to ensure an appropriate amount of oil is secured in the compressors. In order to avoid oil shortage in the compressor, maximum operation is normally forcibly conducted at regular intervals to recover oil from indoor units. This method, typically employed in a standard VRF, causes the system to overheat or overcool and thus waste energy.

In Panasonic VRF systems, a sensor for detecting oil levels is mounted in each compressor. In installations with multiple outdoor units, a shortage of oil in one compressor can be compensated for by recovering oil either from another compressor in the same unit, from a compressor in an adjacent outdoor unit, or from a connected indoor unit. Panasonic VRF systems provide users with a comfortable environment whilst saving energy.

The Panasonic system efficiently manages oil recovery in three stages; minimising the frequency of forced oil recovery while reducing energy cost and maintaining comfort.

STAGE-1

Panasonic compressors are equipped with sensors which monitor oil levels precisely at all times. If oil levels fall, oil can be transferred from other compressors within the same outdoor unit.



STAGE-2

If oil levels in all compressors within the outdoor unit fall, oil can be replenished from adjacent outdoor units.

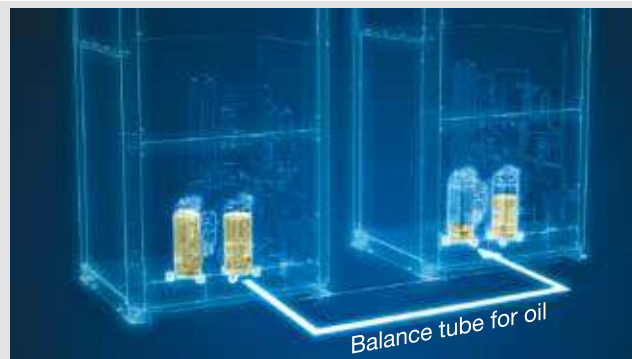

STAGE-3

Forced oil recovery is implemented only if oil levels become insufficient in spite of above measures. The Panasonic system's design concept is radically different from conventional oil systems.

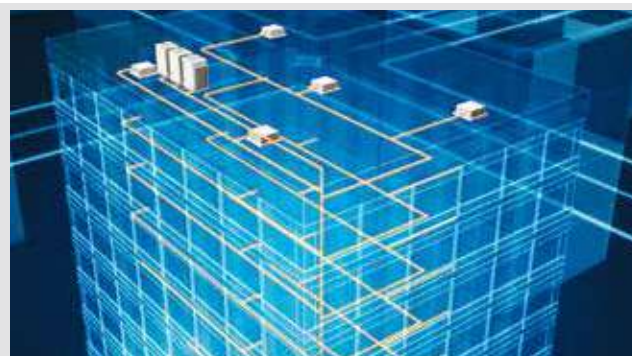

Features of 3-stage oil recovery design

1 Oil sensors installed in each compressor

Oil sensors installed in each Panasonic compressor precisely monitor oil levels, eliminating unnecessary oil recovery.



2 Highly functional oil separator

Thanks to extended separate piping, oil recovery efficiency reaches 90%, minimising the oil to be discharged from the compressor.



ECONAVI Detects Inefficiencies and Saves Energy

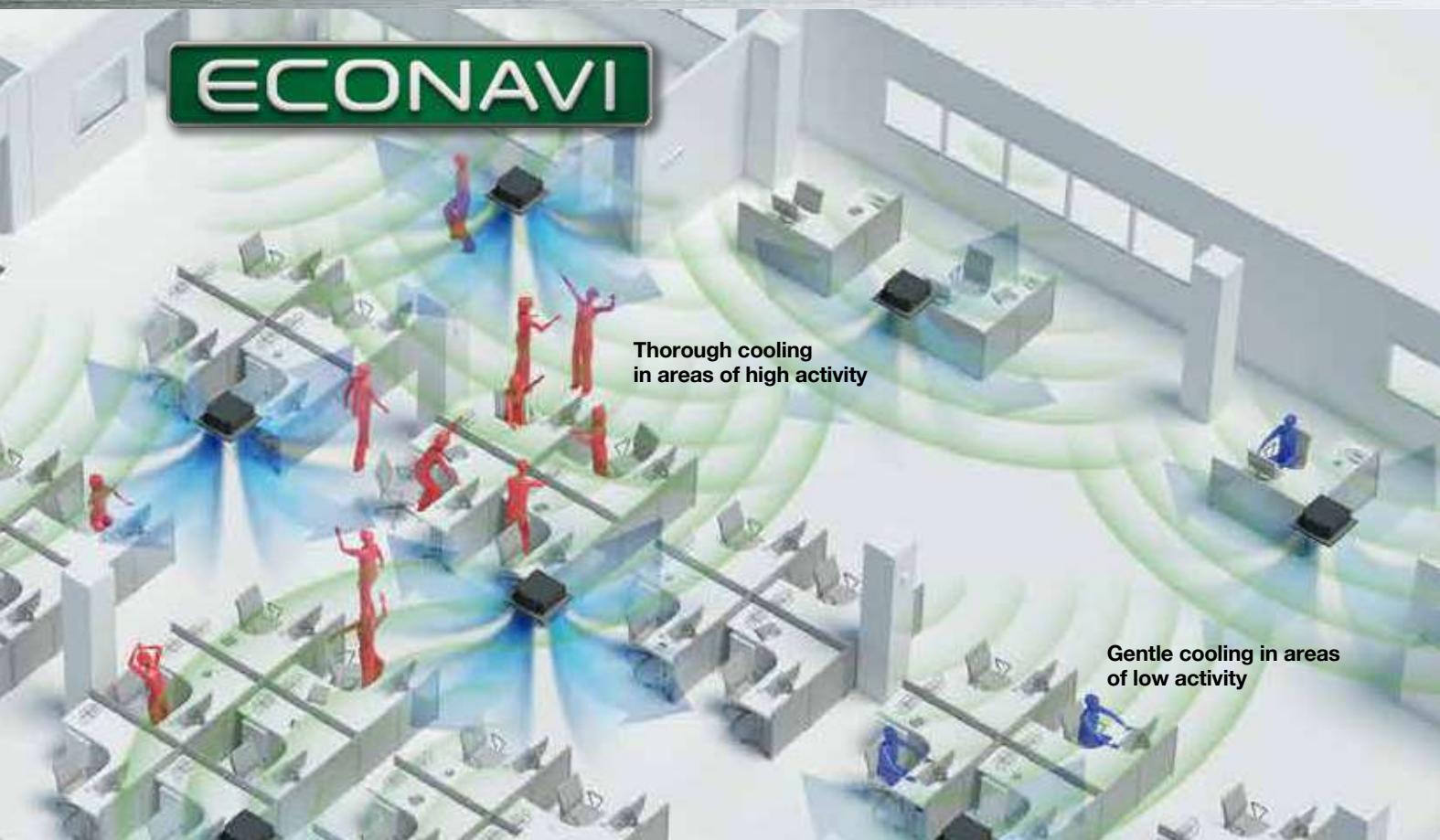

Detection of the level of activity enables precise power saving.

Presence or absence of people at their desks and the level of activity in the office are detected in real time. Set temperature is automatically adjusted to optimise the lower power consumption.



- In the morning**
Thorough cooling when there is a high level of activity
- In the afternoon**
Reduced cooling when there are fewer people
- At night**
Automatic Thermo Off depending on conditions at the end of the day*

Human activity and presence detection

| Activity detection | | Presence detection | |
|--------------------------|---------------------------|---|-----------------------|
| HIGHER ACTIVITY | LOWER ACTIVITY | After 20 mins absence | After 3 hours absence |
| Cooling Set Temp. +/-0°C | Cooling Set Temp. +1°C | Cooling Set Temp. +2°C | Cooling Thermo OFF* |
| Heating Set Temp. -1°C | Heating Set Temp. +/-0 °C | Heating Set Temp. -2°C | Heating Thermo OFF* |
| Every 2 min | Every 2 min | After 3 hours the setting can change to Stop or Temperature Shift | |

*Depending on conditions, the setting can change to Switch Off After 3 Hours, Thermo Off or Temperature Shift.

ECONAVI

Remote ECONAVI sensor allows optimum energy operation

Pillars, walls, cabinets and other fittings obstruct the sensor, reducing the area of detection and lowering the energy-saving effect. Taking into consideration blind spots, Panasonic enables the optimum layout for sensors in any office.

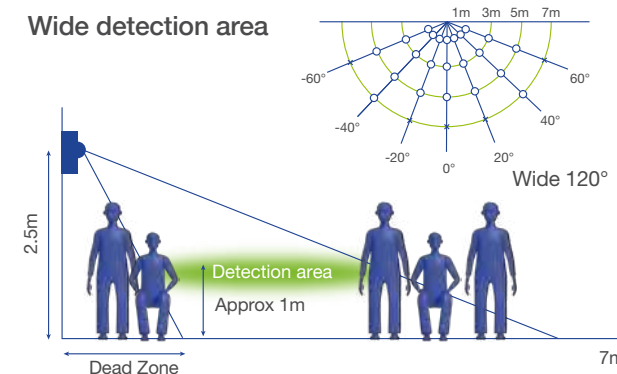

- A sensor is remotely set to maximise the detection area.
- Installation flexibility ready for indoor unit replacement and layout changes.



ECONAVI sensor CZ-CENSC1 Panasonic enables use with various types of indoor units

Providing outstanding energy-saving performance, Panasonic's inverter VRF System can be connected to ECONAVI to detect when energy is being wasted. ECONAVI senses the presence or absence of people and the level of activity in each area of an office. When unnecessary heating or cooling is detected, indoor units are individually controlled to match office conditions for energy-saving operation.

ECONAVI VRF Field Test

- Indoor units (12)
- Sensors (12)
- Trial term: 11 Apr - 16 May 2014
- Location: Panasonic Malaysia Building
- Office floor: Cooling capacity 112kW
- Testing conditions:
 - Remote controller setting temperature 23°C
 - Setting time AM7:00-PM21:00
- Units used

| System | Outdoor unit | Indoor unit |
|--------------|--------------|---------------|
| ① CU-L7-6 | U-20ME1E8 | 1 S-106MU1E5 |
| | | 2 S-106MU1E5 |
| | | 3 S-106MU1E5 |
| | | 4 S-106MU1E5 |
| | | 5 S-56MU1E5 |
| ② CU-L7-7 | U-20ME1E8 | 6 S-106MU1E5 |
| | | 7 S-106MU1E5 |
| | | 8 S-56MU1E5 |
| | | 9 S-106MU1E5 |
| ③ CU-L7-7 | U-14ME1E8 | 10 S-106MU1E5 |
| | | 11 S-56MU1E5 |
| | | 12 S-106MU1E5 |

Power consumption

Without ECONAVI
With ECONAVI

Up to **15%** energy saving

Energy-saving effect tested and verified by Field test

High-spec Wired Remote Controller

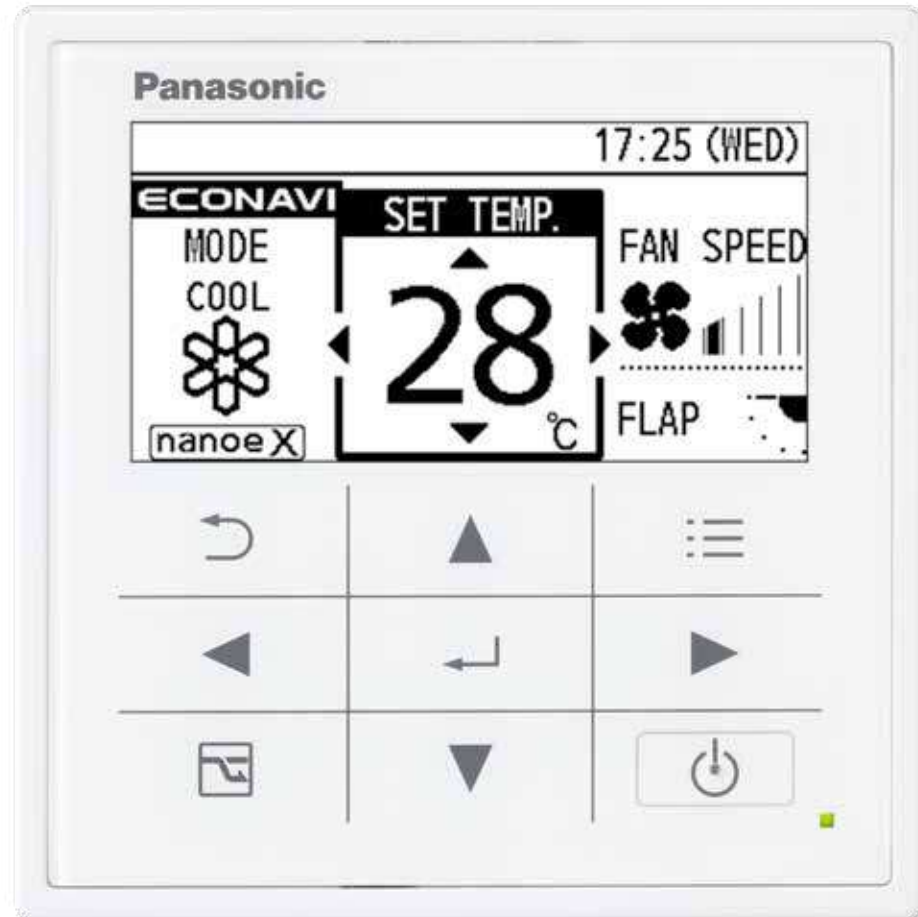

CZ-RTC5B Actual size

Large 3.5" Full-dot LCD with White LED Backlight

Characters and icons are clearly displayed for improved visibility. The display is also large enough to provide a wide range of information for easy confirmation of operation conditions.

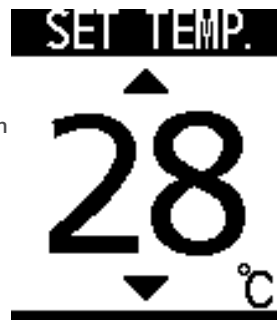

Stylish, Easy-to-use Touch Key Design

The elegant, flat design features large touch keys in a simple layout enabling easy, intuitive operation.



Multiple control settings to meet a wide range of air conditioning needs

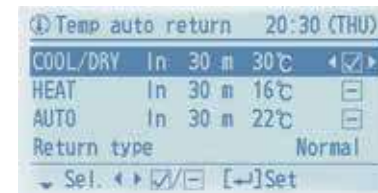

Temperature Auto Return

Even if you change the temperature setting, after a set time it automatically returns to the original temperature setting. You can set temperature auto return time in 10-minute intervals within a period of 4 hours.

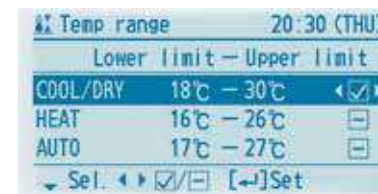

Temperature Setting Range

You can set the upper and lower temperature limits. Doing this helps reduce power consumption due to over cooling or heating. Setting is possible in the Cooling, Heating and Dry modes.

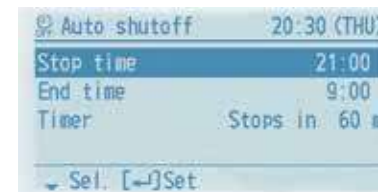

Auto Shutoff

Air conditioning automatically stops after a set time, so you don't have to worry about forgetting to switch the unit off. Even if you manually switch the unit back on after it has stopped, it automatically switches off again after the set time.

Wide range of controls for extra convenience

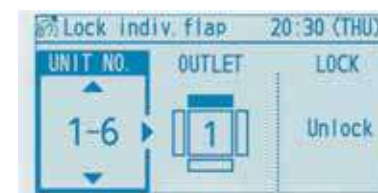

Individual Flap Control

(Lock individual flap only for 4-way cassette U1 type)

Each of the 4-directional outlets can be selected and locked to provide efficient air distribution that matches the indoor unit layout. Indoor units can be set individually.

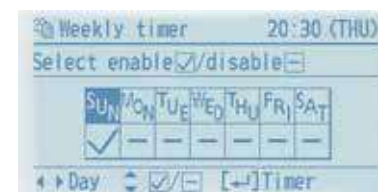

Weekly Timer

This lets you specify 8 Start/Stop times and temperature presets for each day of the week.

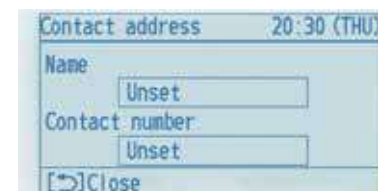

Service Contact Address

Once you have register service contact details, they are automatically displayed if a problem with the air conditioner occurs. This helps you quickly deal with the situation.

Convenient Controls



Operation Lock

To prevent operation by anyone other than the supervisor, operation keys can be locked. This prevents unauthorized personnel from changing temperature settings, airflow rate, airflow direction and other settings.



Filter Information

Filter information is indicated for cleaning after a set time of operation period has past. The number of hours can be adjusted.



Quiet Operation Mode

There's a Quiet mode that reduces the outdoor unit's operating noise. The mode can be switched On/ Off and Start/ End times can be set.



Maintenance Function

Display of outdoor malfunction data, service contact details, filter cleaning remaining time and other data enables at-a-glance verification of maintenance information with the remote controller.



Repeat OFF Timer

You can stop the operation after a certain period of time each time operation is performed.



Setting Lists

Information concerning current settings is displayed in the remote controller's LCD for easy confirmation.



Function List

| | Control Item | Controllability | |
|---------------------------|--|-------------------------|-----------------|
| | | "B" model | Non "A-B" model |
| Menu items | Basic instructions | ● | ● |
| | FLAP | ● | ● |
| | Individual louver control (Lock individual flap only for 4-way cassette U2 type) | ● | ● |
| | ON/ OFF timer | ● | ● |
| | Weekly timer | ● | ● |
| | Filter information | ● | — |
| | Outing function | ● | ● |
| | Quiet operation mode | ● | — |
| | Energy saving | ● | ● |
| | Initial settings | ● | ● |
| | Ventilation | ● | ● |
| | Energy Saving | Temperature auto return | ● |
| Temperature setting range | | ● | ● |
| Auto shutoff | | ● | ● |
| Schedule peak cut | | ● | — |
| Repeat off timer | | ● | ● |
| ECONAVI on/ off | | ● | — |
| Maintenance Function | Outdoor unit error data | ● | — |
| | Service Contact address | ● | ● |
| | RC setting mode | ● | ● |
| | Test Run | ● | ● |
| | Sensor Information | ● | ● |
| | Service check | ● | ● |
| | Simple/ Detailed Settings | ● | ● |
| Auto address | ● | ● | |



Air Handling Unit Kit

AHU Kit connects FSV-EX and FSV outdoor units to Air Handling Units System

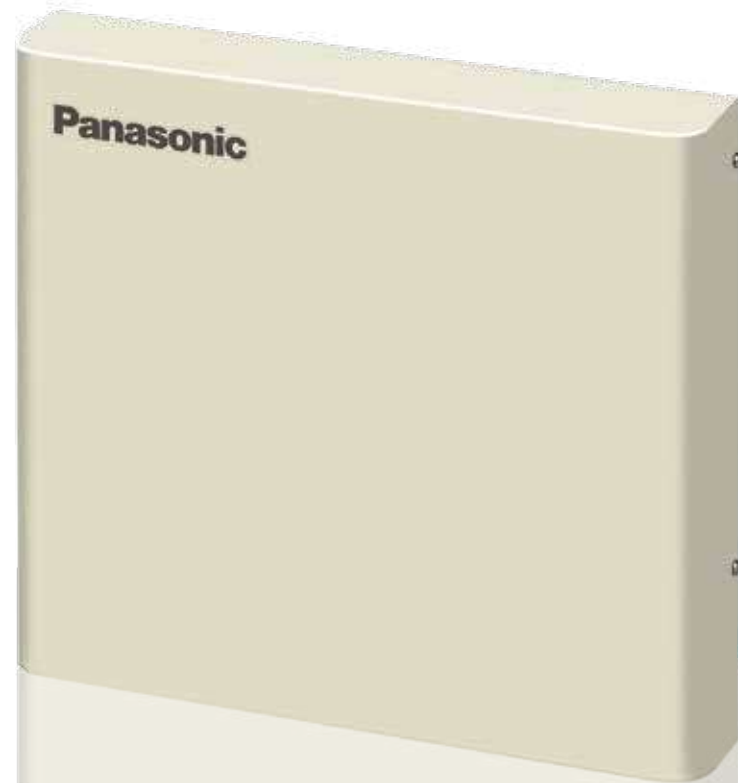

If you require this fresh air solution, please contact an authorized Panasonic distributor.

Connect Air Handling Unit to your FSV-EX and FSV systems for a high efficiency operation.

Application: Hotels, offices, server rooms or all large buildings where air quality control such as humidity control and fresh air are needed.

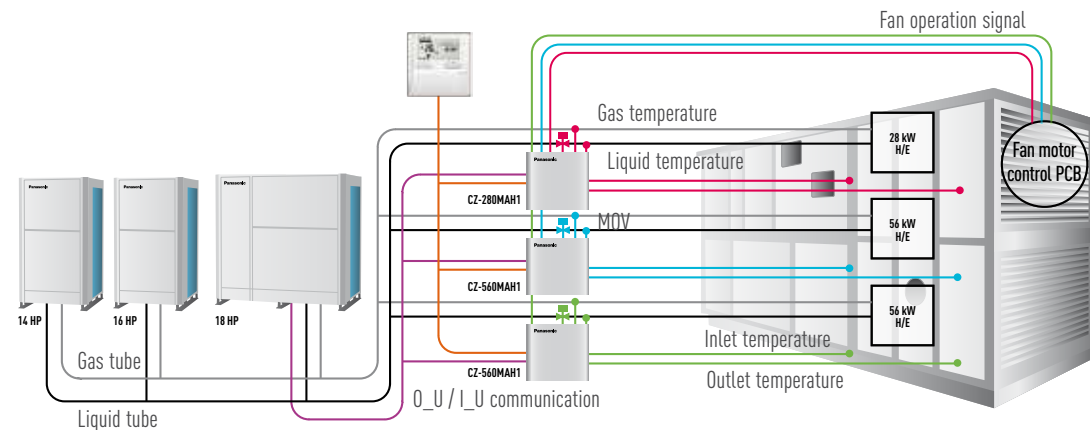

AIR HANDLING UNIT Kit to connect to your ventilation system

AHU Connection Kit

PCB, Power trans, Terminal block



Remote control can be easily installed on the AHU Kit box. (Remote control must be purchased separately.)

Expansion valve



Thermistor x2 (Refrigerant: E1, E3)



Thermistor x2 (Air: Tf, Tb)



Optional Remote controller

Timer remote controller. CZ-RTC4



Optional parts: Following functions are available by using different type of control accessories:

CZ-RTC4 Wired remote controller

- Operation-ON/OFF
- Mode select
- Temperature setting
- * Fan operation signal can be taken from the PCB.

T10 terminal

- Input signal= Operation ON/OFF
- Remote controller prohibition
- Output signal= Operating-ON status
- Alarm output (by DC12 V)

OPTION terminal, DC12V outlet

- Output signal= Cool / Heat/Fan status
- Defrost
- Thermostat-ON

CZ-CAPBC2 Seri-para I/O unit for each indoor unit

- Temperature setting by 0-10 V or 0-140 Ω input signal
- Room (inlet air) temp outlet by 4-20 mA
- Mode select or/and ON/OFF control
- Fan operation control
- Operation status output/ Alarm output

Technical Zoom

- Max. piping length: 100m (actual)/ 120m (equivalent)
- Difference between longest and shortest piping from first branch: 10m
- Max. length of branch tubing: 12m
- * Other conditions to be referred the standard piping design regulations.
- Available temperature range in Heating: -20 °C (WB)~15 °C (WB)
- Available temperature range for the suction air at AHU Kit: Cool: 18~32 °C / Heat: 16~30 °C

CZ-280MAH1 // CZ-560MAH1

- The system controlled by the suction air (or return air from room) temperature as same as standard indoor unit. (Selectable mode: Automatic / Cooling / Heating / Fan / Dry (but same as Cool))
- The discharge air temperature is also controlled to prevent too-low air discharge in Cooling or too-high air discharge in Heating. (in case of VRF system)
- Demand control (Forcible thermostat-OFF control by operating current)
- Defrost operation signal, Thermo-ON/OFF states output
- External target temperature setting via Indoor/Outdoor signal interface is available with CZ-CAPBC2. (Ex. 0 - 10 V)
- Connectable with P-LINK system

System and regulations. System overview

- A: AHU Kit controller box (with control PCB)
- B: AHU equipment (Field supplied)
- C: Remote controller (option parts)
- D: Outdoor unit
- E: Gas piping (Field supplied)
- F: Liquid piping (Field supplied)
- G: Electronic expansion valve
- H: Thermistor for Gas pipe (E3)
- I: Thermistor for Liquid pipe (E1)
- J: Thermistor for Suction air (TA)
- K: Thermistor for Discharge air (BL)
- L: Inter unit wiring
- M: Magnetic relay for operating the blower (Field supplied)

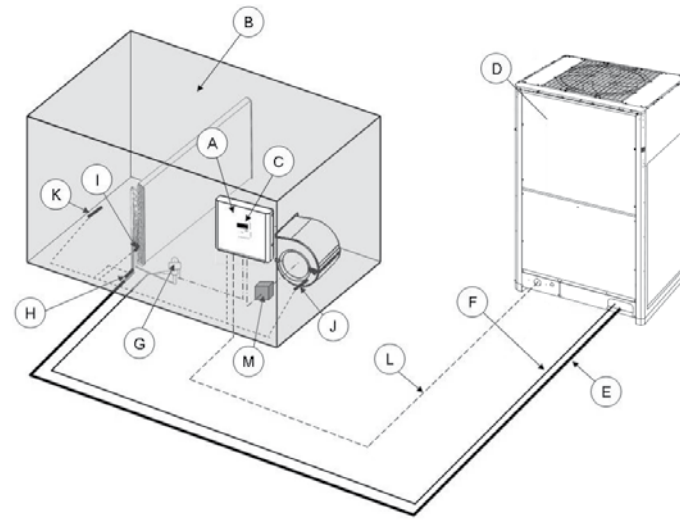

AHU Connection Kit / System Combination

| | Capacity (HP) | Outdoor unit combination | | | |
|---|------------------|--------------------------|-----------|-----------|-----------|
| 2-WAY FSV-EX ME2 Series (Space-saving Combination)* | 28.0 kW (10 HP) | U-10ME2H7 | | | |
| | 56.0 kW (20 HP) | U-20ME2H7 | | | |
| | 85.0 kW (30 HP) | U-14ME2H7 | U-16ME2H7 | | |
| | 113.0 kW (40 HP) | U-20ME2H7 | U-20ME2H7 | | |
| | 140.0 kW (50 HP) | U-14ME2H7 | U-16ME2H7 | U-20ME2H7 | |
| | 168.0 kW (60 HP) | U-20ME2H7 | U-20ME2H7 | U-20ME2H7 | |
| | 196.0 kW (70 HP) | U-10ME2H7 | U-20ME2H7 | U-20ME2H7 | U-20ME2H7 |
| | 224.0 kW (80 HP) | U-20ME2H7 | U-20ME2H7 | U-20ME2H7 | U-20ME2H7 |

*These are combination examples for space-saving combination. These combinations are also compatible for high efficiency models on page 34-35.

Project References

Office

Hong Kong Red Cross Headquarters



Air Conditioning System:
VRF 2-way FSV ME1 series:
2 systems
Indoor Units: 2 units
AHU Kit: 6 units
Cooling Capacity: 280 kW / 80 USRT



Residential + Commercial

Malaysia Utropolis, Glenmarie



Air Conditioning System:
VRF 2-way FSV ME1 series:
29 systems
Indoor Units: 168 units
AHU Kit: 9 units
Cooling Capacity: 3,077 kW / 875 USRT



AHU Connection Kit / System Combination

AHU kit combination

| | | | |
|------------|------------|------------|------------|
| CZ-280MAH1 | | | |
| CZ-560MAH1 | | | |
| CZ-560MAH1 | CZ-280MAH1 | | |
| CZ-560MAH1 | CZ-560MAH1 | | |
| CZ-560MAH1 | CZ-560MAH1 | CZ-560MAH1 | |
| CZ-560MAH1 | CZ-560MAH1 | CZ-560MAH1 | |
| CZ-560MAH1 | CZ-560MAH1 | CZ-560MAH1 | CZ-280MAH1 |
| CZ-560MAH1 | CZ-560MAH1 | CZ-560MAH1 | CZ-560MAH1 |

Design Support Software for FSV



Features the unique Mounting Scheme function providing more thorough spec-in and tender quotation support for easier, faster completion of work.

The Panasonic VRF Designer software can be used for all Panasonic FSV and FSV-EX ranges

Panasonic has identified the importance of ever-increasing demands for fast and accurate responses to customer requests in our industry. More and more emphasis is being placed upon energy-efficiency in our marketplace. The ability to calculate cooling/heating loads and produce information of actual design conditions is a major advantage to any architect, consultant, contractor or end user.

Panasonic understands the time-poor and demanding industry we are in and we are pleased to announce the launch of the next generation of our system design software program.

The Panasonic VRF Designer software has been customised to make the selection and design process as quick and easy as possible.

The design package utilises system wizards and import tools to enable both simple and complex systems to be created. In addition, the system will allow outdoor and indoor units to be dragged on an interactive desktop. This allows users to create everything from realistic floor plans with detailed piping and wiring schematics to send out with quotations, through to installation guidance drawings.

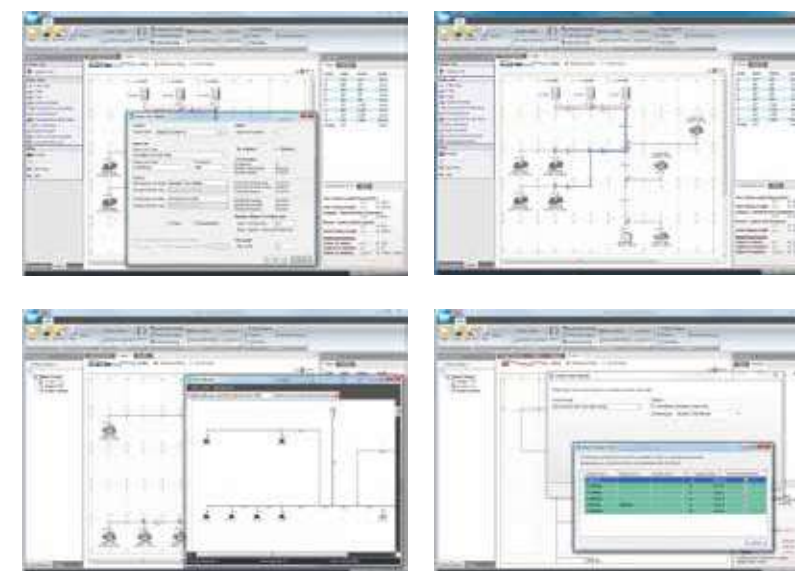
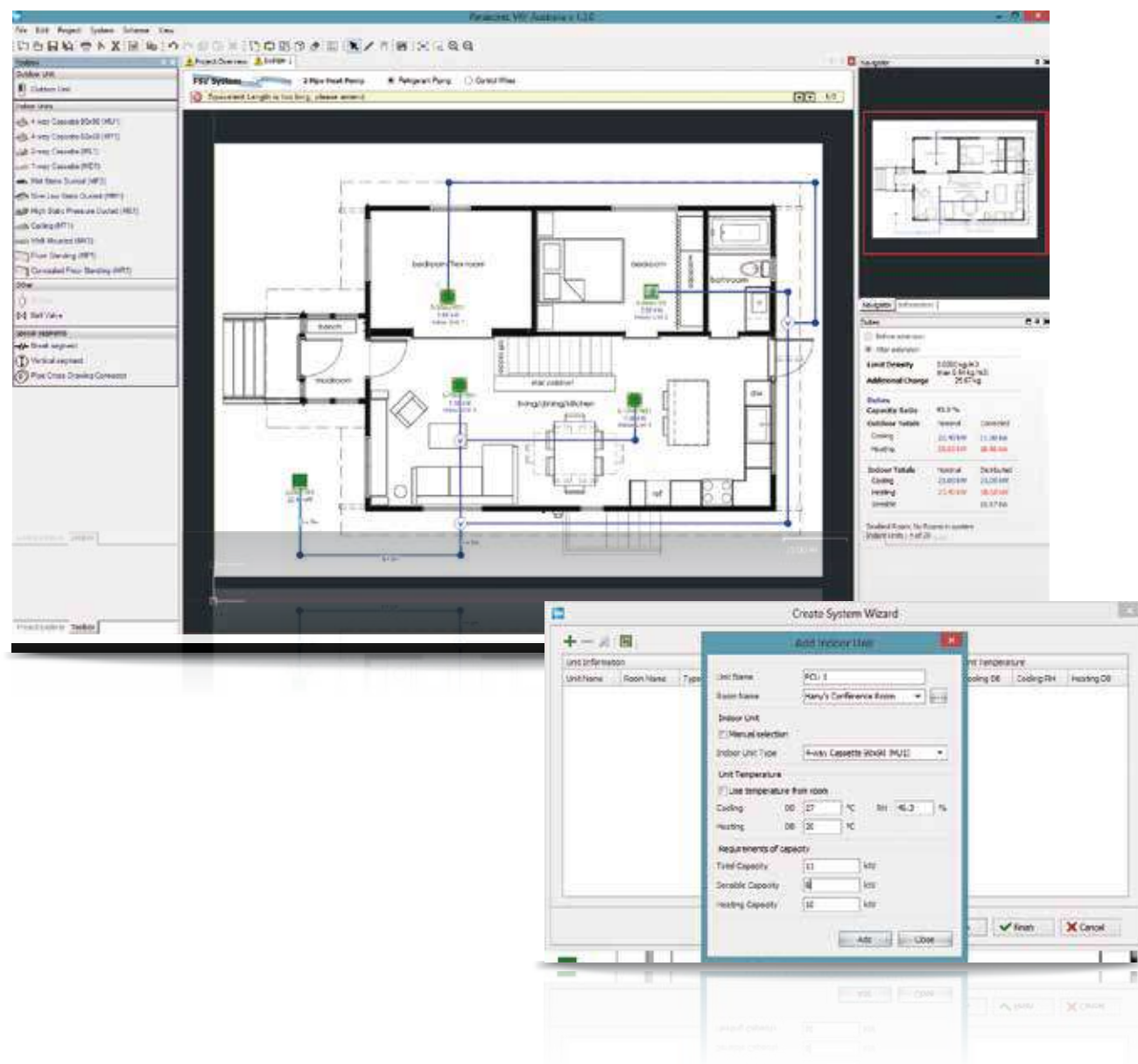

Features include

- Mounting scheme
Design selection from building floor drawing.
- Any kind of drawing format. (dxf, jpg, png..etc.)
- Conventional principal scheme.
- Easy to use system wizards.
- Auto piping and wiring features.
- Converted duties for conditions and pipework
- Auto(CAD) [dxf], Excel and PDF export.
- Detailed wiring and pipework diagrams.
- Automatic price quotation.
- Automatic tender document assist.

FSV Systems

FSV systems are designed for energy savings, high efficiency, and high durability with strong cooling power even operating at high ambient temperature. Panasonic continuously apply advanced technologies to meet the requirements of diverse situations and contribute to the creation of comfortable living spaces.



FSV EX ALL INVERTER

2-WAY FSV-EX ME2 Series

Extraordinary energy-saving performance and powerful operation

Space-saving Combination Model

Cooling or Heating Type

Hi-Durability Model

- Wide range of systems from 8HP to 80HP
- Class-leading EER of 5.3 (for 8HP model)
- Industry-leading low noise of 53.0 DB (8HP model)
- Cooling operation possible with outdoor temperature as high as 52°C (DB)
- Long maximum pipe length (up to 1,000 m)
- Up to 64 indoor units connectable
- External static pressure of 80 Pa
- Extended operating range allows heating with outdoor temperatures as low as -25°C (WB)
- Suitable for R22 renewal projects 



High Efficiency Combination Model

Cooling or Heating Type

Hi-Durability Model

- Wide range of systems from 8HP to 64HP
- Class-leading EER of 5.3 (for 8HP model)
- Higher EER than the Space-saving Combination Model e.g., a combination of two 10HP units delivering 20HP reduces compressor load.
- Suitable for R22 renewal projects 



FSV INVERTER

2-WAY Mini-FSV LE2 Series

For small-scale commercial and residential use

Cooling or Heating Type 1/3-phase

4/5/6 HP

- High external static pressure 35Pa
 - Wide operation range: Cooling: -10°C to 46°C DB, Heating at: -20°C to 18°C WB
 - Refrigerant chargeless up to 50m
 - Extraordinary energy saving: 5.08* EER for 4HP model
 - Demand response (Peak cut) by optional parts.
 - Maximum number of connectable indoor units : 9*
 - Diversity ratio 50-130%
 - DC inverter technology combined with R410A for excellent efficiency
 - Demand response (Peak cut) by optional parts.
 - One ampere starting current
 - Full range of indoor units and control options
 - Auto restart from outdoor unit
 - Hi-durability outdoor unit model is available.
 - Suitable for R22 renewal projects 
- * 6 HP only; 4 HP for 7 units, 5 HP for 8 units.



FSV INVERTER

2-WAY Mini-FSV LE1 Series

For small-scale commercial and residential use

Cooling or Heating Type 3-phase

8/10 HP

- High external static pressure 35Pa
- Wide operation range: Cooling: -10°C to 46°C DB, Heating at: -20°C to 18°C DB
- Maximum number of connectable indoor units : 13
- Diversity ratio 50-130%
- DC inverter technology combined with R410A for excellent efficiency
- Actual piping length: 150m (Total piping length: 300m)
- System difference of elevation: 50m / 40m (outdoor above/below)
- Difference in elevation between indoor units: 15m
- Demand response (Peak cut) by optional parts.
- One ampere starting current
- Full range of indoor units and control options
- Auto restart from outdoor unit
- Hi-durability outdoor unit model is available.
- Suitable for R22 renewal project 



High-efficiency & Space-saving VRF system

2-WAY FSV-EX ME2

Remarkable improvement on key components



Extraordinary energy-saving performance

1 Multiple large-capacity all inverter compressors (more than 14HP)

Two independently controlled inverter compressors achieve high efficiency. Redesigned components in the body provide performance improvement especially in the rated cooling condition and EER performance.



2 Enlarged heat exchanger surface area with triple surface*

The new heat exchanger features a triple-surface construction. Compared to the divided dual-surface construction in current models, there is no division of space and the area for heat exchange is larger. Also, highly efficient piping pattern increases heat exchange performance by 5%.

* For 8 & 10HP unit, the heat exchanger is 2 row design.

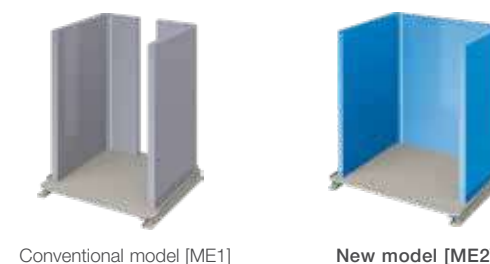

Redesigned for smooth and better air discharge

3 Newly designed curved air discharge bell mouth for better aerodynamics

The new curved shape with integrated top and bottom assure smooth exhaust flow. This gives more air-volume with same sound level, less power input at same air-volume.

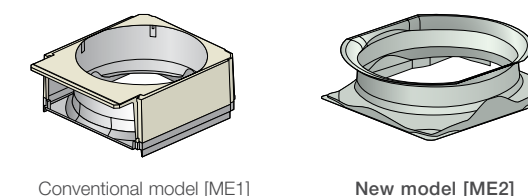

4 Large air discharge area with new flush surface top panel

To reduce air resistance, instead of a tubular fan design, a new large flat fan guard design, flush with the top panel, is employed. This design lead to the improvements in air resistance, but also contributed to better appearance designing.



High-efficiency & Space-saving VRF system

2-WAY FSV-EX ME2

A large number of indoor units can be connected

Up to 64 indoor units can be connected in a single system for ultimate design flexibility.

*Maximum number of indoor units depends on outdoor unit capacity.

Up to 64 Indoor Units Connectable!



Increased piping length for greater design flexibility

Adaptable to various building types and sizes
Actual piping length : **200m**
(equivalent piping length : 210m)

*Elevation difference of Max. 90m in case of ODU is higher than IDU may be allowed following certain conditions. Please consult with Panasonic sales engineers in case of piping elevation of over 50m is required.

*1: 40 m if the outdoor unit is below the indoor unit.

Max. total piping length:1,000m

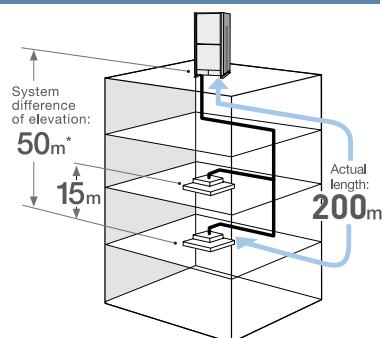

Connectable indoor/outdoor unit capacity ratio up to 130% *

FSV systems attain maximum indoor unit connection capacity of up to 130 %* of the unit's connection range, depending on the outdoor and indoor models selected. So for a reasonable investment, FSV systems provide an ideal air conditioning solution for locations where full cooling/heating are not always required.

| SYSTEM / HP | 8 | 10 | 12 | 14 | 16 | 18 | 20 | 22 | 24 | 26 | 28 | 30 | 32 | 34 | 36 | 38 | 40 | 42 | 44 | 46 | 48 | 50 | 52 | 54 | 56 | 58 | 60 | 62 | 64 | 66 | 68 | 70 | 72 | 74 | 76 | 78 | 80 | | |
|--------------|----|----|----|----|----|----|----|----|----|----|----|----|----|----|----|----|----|----|----|----|----|----|----|----|----|----|----|----|----|----|----|----|----|----|----|----|----|----|----|
| MNcIU : 130% | 13 | 16 | 19 | 23 | 26 | 29 | 33 | 36 | 40 | 43 | 46 | 50 | 53 | 56 | 59 | 63 | 64 | 64 | 64 | 64 | 64 | 64 | 64 | 64 | 64 | 64 | 64 | 64 | 64 | 64 | 64 | 64 | 64 | 64 | 64 | 64 | 64 | 64 | 64 |

MNcIU : Maximum Number of Connectable Indoor Unit

Note: If more than 100% indoor units are operated with a high load, the units may not perform at the rated capacity. For the details, please consult with an authorised Panasonic dealer

- * If the following conditions are satisfied, the effective range is above 130 % up to 200 %.
- i) Obey the limited number of connectable indoor units.
- ii) The lower limit of operating range for heating outdoor temperature is limited to -10°CWB (standard -25°CWB).
- iii) Simultaneous operation is limited to less than 130 % of connectable indoor units.

Excellent energy savings

The operation efficiency has been improved using highly efficient R410A refrigerant, new DC inverter compressor, and new heat exchanger design.

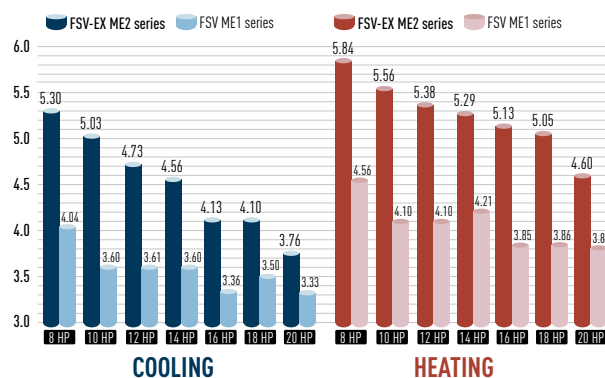

Up to 50m length difference between the longest and the shortest piping from the first branch

Flexible piping layout makes it easier to design systems for locations such as train stations, airports, schools and hospitals.

- Up to 64 units can be connected to one system.
- Difference between maximum and minimum pipe runs after first branch can be a maximum of 50m.
- Larger pipe runs can be up to 200m.

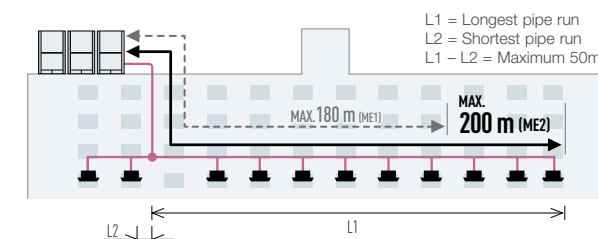

Extended operating range

Cooling operation range:
-10°C DB to +52°C DB

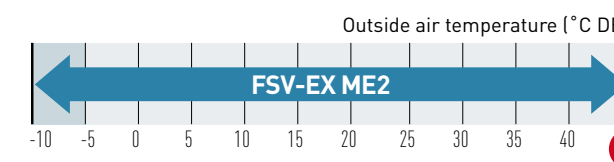

Heating operation range:

Extended heating operation range enables heating even when the outdoor temperature is as low as -25°C. Using a wired remote control, indoor heating temperature range can be set from 16°C to 30°C*.

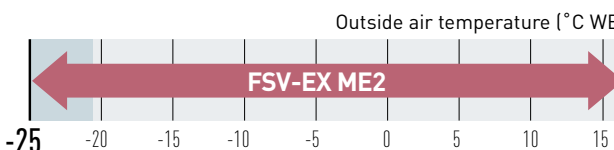

* Depending on the type of remote controller.

Compact design

The new ME2 series has reduced the installation space required with up to 20 HP available in a single chassis. 8 - 10 HP are able to fit inside a lift for easy handling on site.

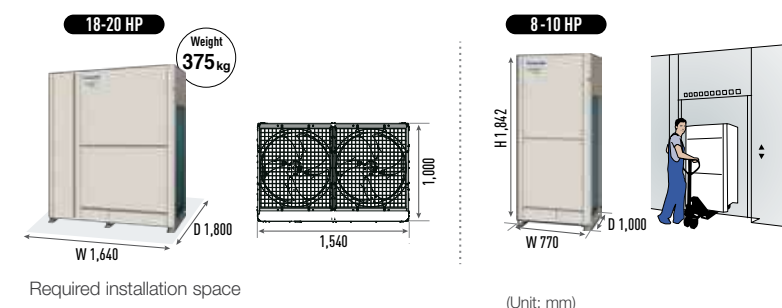

Newly designed fan

Optimised air flow

Newly designed fan and bell-mouth reduces stress on the fan by dispersing air quickly. Thus, lower air resistance results in lower energy consumption.

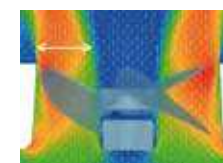

Noise reduction

Turbulence (blue) can be suppressed and the unwanted noise can be reduced. Even though a high speed fan is utilised, the noise level is still very low.

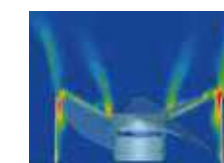

High-efficiency & Space-saving VRF system

2-WAY FSV-EX ME2

High external static pressure on condensers

With a newly designed fan, fan guard, motor, and casing, new models can be custom-installed on-site to provide up to 80 Pa of external static pressure. An air discharge duct prevents shortages of air circulation, allowing outdoor units to be installed on every floor of a building.



Fan

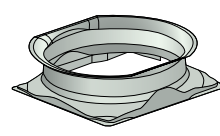

Fan Motor and Casing

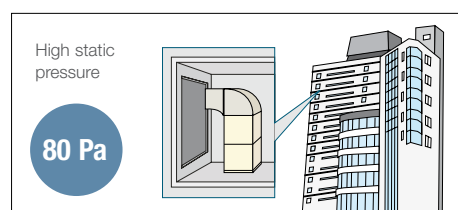

Extended compressor life by uniform compressor operation time

The total run-time of compressors are monitored by a built-in microcomputer, which ensures that operation times of all compressors within the same refrigerant circuit are balanced.

Compressors with histories showing shorter run times are selected first, ensuring equal wear and tear across all units and extended the working life of the system.

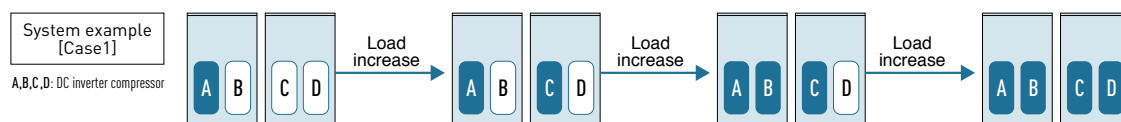

* Depend on accumulated operation time of each compressors.

* Compressor priority has possibility to be changed.

(e.g) Case1: A→C→B→D, Case2: C→A→D→B, Case3: A→C→D→B, Case4: C→A→B→D

Automatic backup operation in the case of compressor failure or outdoor unit malfunction

Except for 8, 10 & 12 HP single unit installation

*Backup operation allows uninterrupted cooling or heating to continue whilst waiting for service. Users should contact their authorised service centre as soon as fault occurs.

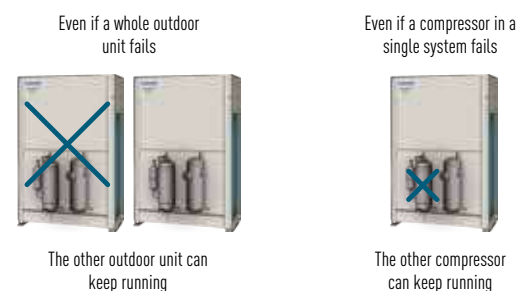

Automatic backup operation.

Demand response

Featuring inverter control technology, all Panasonic FSV systems are Demand Response Management (DRM) ready. With this control, power consumption at times of peak load can be set in three steps to deliver optimum performance. This helps to reduce annual power consumption with minimal loss in comfort.

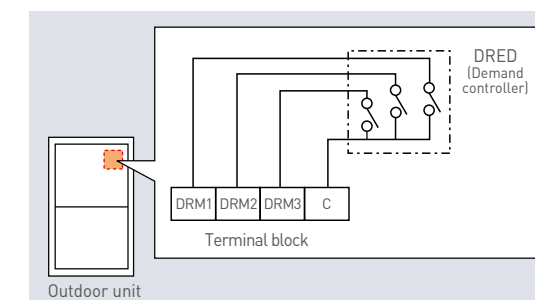

Simple Demand Response with the CZ-CAPDC4

Demand control terminal is available to control 0-50-75-100% of capacities.

*CZ-CAPDC4 is required as an option

| Demand Response Signal | Power Input |
|------------------------|-------------|
| DRM 1 | 0% |
| DRM 2 | 50% |
| DRM 3 | 100% |

Flexible Demand Response with the CZ-CAPDC2 *1

Setting is possible as 0% or in the range from 40 to 100% (in steps of 5%). At the time of shipping, setting has been done to the three steps of 0%, 70% and 100%.

*1 An outdoor Seri-Para I/O unit (CZ-CAPDC2) is required for demand input signal.

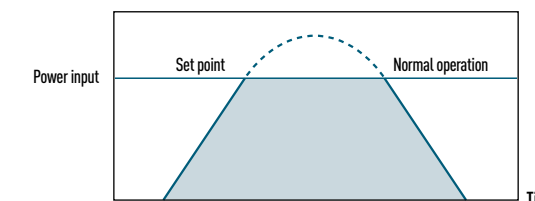

| | Power input | |
|---------|-------------------------------|----------------------------|
| Level 1 | 100% (Preset) | Possible to change 40-100% |
| Level 2 | 70% (Preset) | |
| Level 3 | 0% (Always in stop condition) | |

Hi-durability outdoor unit

Corrosion-resistance treated for high resistance to rust and salty air to assure long-lasting performance.

Note: Selecting this unit does not completely eliminate the possibility of rust developing. For details concerning unit installation and maintenance, please consult an authorised dealer.

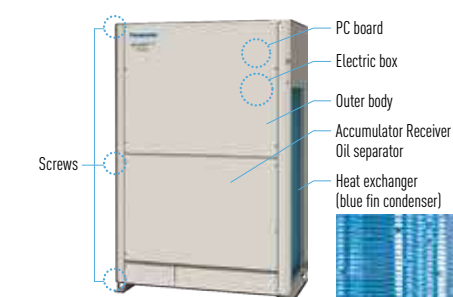

2-WAY FSV-EX ME2 Series **SPACE SAVING COMBINATION MODEL**



8 / 10 HP

According to the installation site, you may choose the setting position in the depth direction of the anchor bolt from A, B or C.

- A: (Installation hole pitch) For removing tube forward
- B: (Installation hole pitch) For removing the downward
- C: (Installation hole pitch)

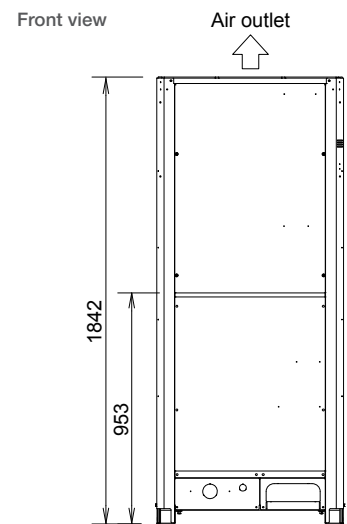
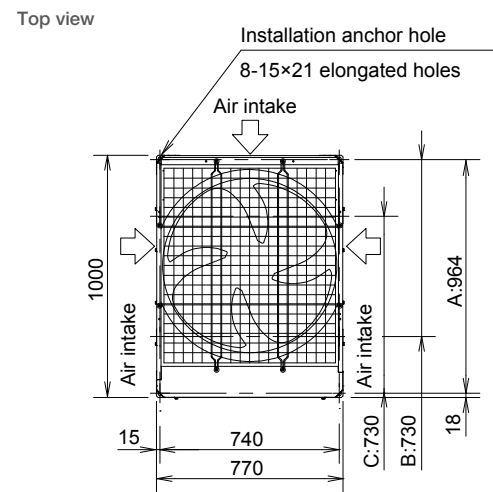

unit: mm

12 / 14 / 16 HP

According to the installation site, you may choose the setting position in the depth direction of the anchor bolt from A, B or C.

- A: (Installation hole pitch) For removing tube forward
- B: (Installation hole pitch) For removing the downward
- C: (Installation hole pitch)

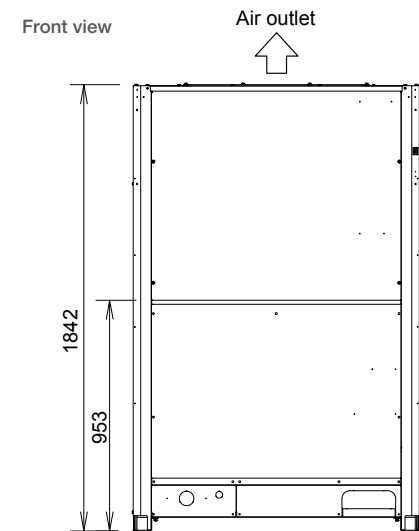
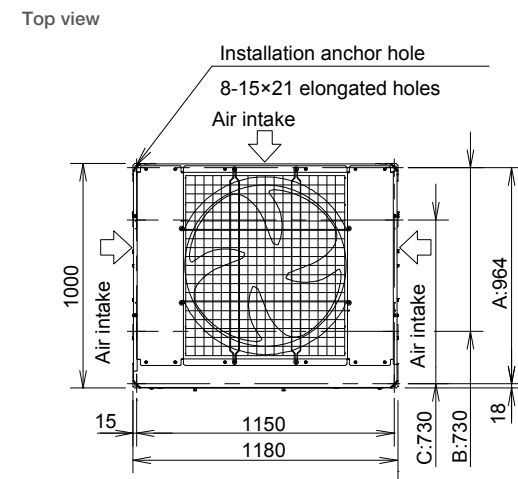

unit: mm

18 / 20 HP

According to the installation site, you may choose the setting position in the depth direction of the anchor bolt from A, B or C.

- A: (Installation hole pitch) For removing tube forward
- B: (Installation hole pitch) For removing the downward
- C: (Installation hole pitch)

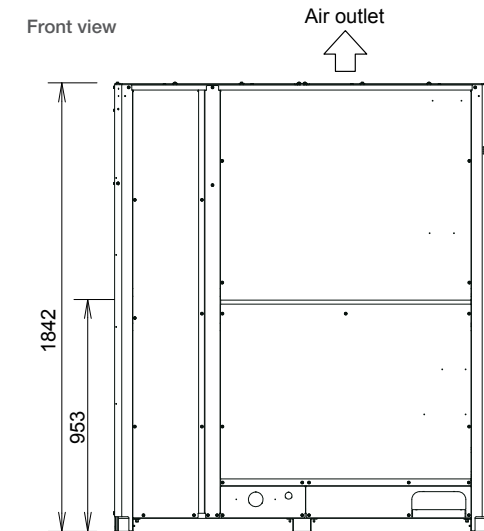
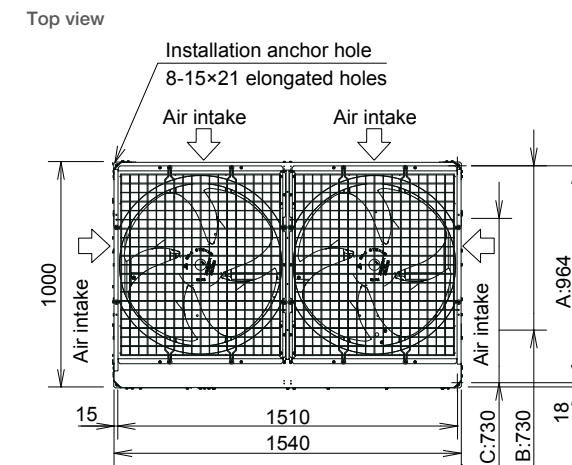

unit: mm

Piping Design

Select installation locations so that the lengths and sizes of refrigerant piping are within the allowable ranges shown in the figure below.

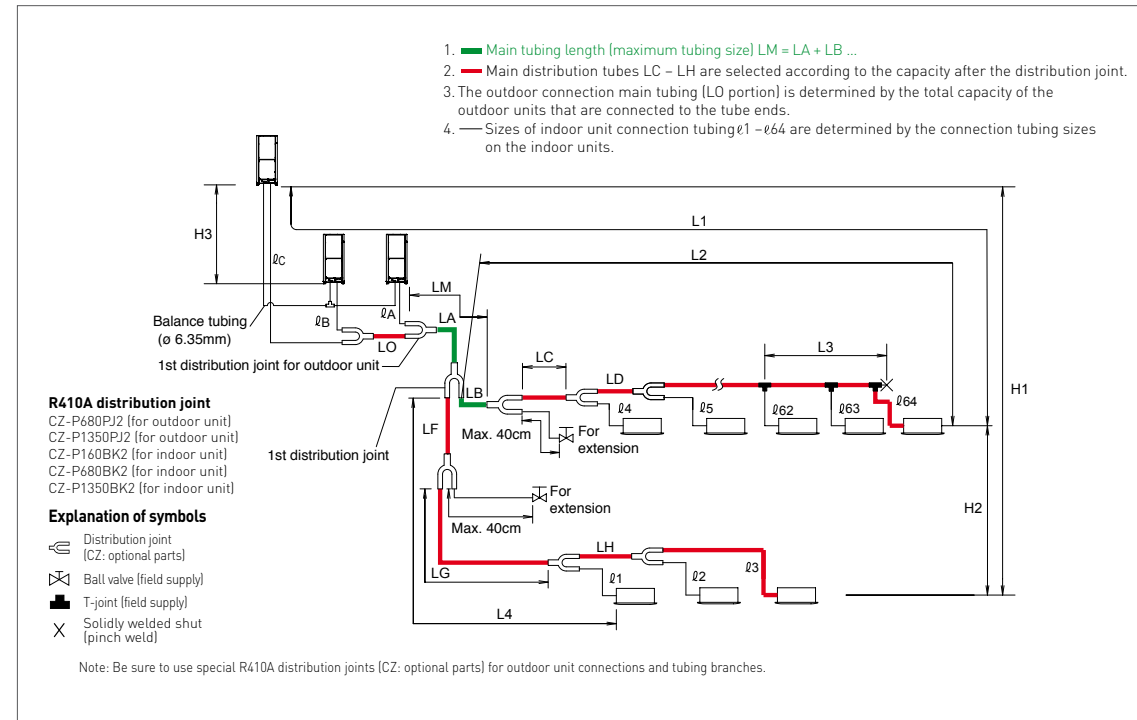

Ranges that apply to refrigerant piping lengths and to differences in installation heights

| Items | Mark | Contents | Length (m) |
|----------------------------------|---|---|--|
| Allowable tubing length | L1 | Max. tubing length | Actual length $\leq 200^{*2}$ Equivalent length $\leq 210^{*2}$ |
| | ΔL (L2-L4) | Difference between max. length and min. length from the 1st distribution joint | $\leq 50^{*5}$ |
| | LM | Max. length of main tubing (at maximum size) * Even after 1st distribution joint, LM is allowed if at maximum tubing length. | — ^{*3} |
| | $\ell 1, \ell 2 - \ell 64$ | Max. length of each distribution tube | $\leq 50^{*7}$ |
| | $L1 + \ell 1 + \ell 2 - \ell 63 + \ell A + \ell B + LF + LG + LH$ | Total max. tubing length including length of each distribution tube (only liquid tubing) | ≤ 1000 |
| Allowable elevation difference | $\ell A, \ell B + LO, \ell C + LO$ | Maximum tubing length from outdoor's 1st distribution joint to each outdoor unit | ≤ 10 |
| | H1 | When outdoor unit is installed higher than indoor unit | ≤ 50 |
| | H2 | When outdoor unit is installed lower than indoor unit | ≤ 40 |
| Allowable length of joint tubing | H3 | Max. difference between indoor units | $\leq 15^{*6}$ |
| | H3 | Max. difference between outdoor units | ≤ 4 |
| Allowable length of joint tubing | L3 | T-joint tubing (field-supply); Max. tubing length between the first T-joint and solidly welded-shut end point | ≤ 2 |

L = Length, H = Height
 NOTE
 1: The outdoor connection main tubing (LO portion) is determined by the total capacity of the outdoor units that are connected to the tube ends.
 2: If the longest tubing length (L1) exceeds 90 m (equivalent length), increase the sizes of the main tubes (LM) by 1 rank for gas tubes and liquid tubes. Use a field supply reducer. Select the tube size from the table of main tubing sizes (Table 3) and from the table of refrigerant tubing sizes (Table 8) on the second following page.
 3: If the longest main tubing length (LM) exceeds 50 m, increase the main tubing size at the portion before 50 m by 1 rank for the gas tubes. Use a field supply reducer. Determine the length less than the limitation of allowable maximum tubing length. For the portion that exceeds 50 m, set based on the main tubing size (LA) listed in Table 3.
 4: If the size of the existing tubing is already larger than the standard tubing size, it is not necessary to further increase the size.
 * If the existing tubing is used, and the amount of on-site refrigerant charge exceeds the value listed below, then change the size of the tubing to reduce the amount of refrigerant.
 Total amount of refrigerant for the system with 1 outdoor unit: 50 kg
 Total amount of refrigerant for the system with 2 outdoor units: 80 kg
 Total amount of refrigerant for the system with 3 outdoor units or 4 outdoor units: 105 kg
 5: When the tubing length exceeds 40 m, increase a longer liquid or gas tubing by 1 rank. Refer to the Technical Data for the details.
 6: If the total distribution tubing length exceeds 500m, maximum allowable elevation difference (H2) between the indoor units is calculated by the following formula. Make sure the indoor unit's actual elevation difference should fall within the figure calculated as follows.
 Unit of account (meter): $15 \times (2 - \text{total tubing length(m)} \div 500)$
 7: If any of the tubing length exceeds 30m, increase the size of the liquid and gas tubes by 1 rank.

Necessary amount of additional refrigerant charge per outdoor unit

| U-8ME2H7(E) | U-10ME2H7(E) | U-12ME2H7(E) | U-14ME2H7(E) | U-16ME2H7(E) | U-18ME2H7(E) | U-20ME2H7(E) |
|-------------|--------------|--------------|--------------|--------------|--------------|--------------|
| 5.5kg | 5.5kg | 7.0 kg | 7.0 kg | 7.0 kg | 7.0 kg | 7.0 kg |

System limitations

| | |
|---|------------------------|
| Max. No. allowable connected outdoor units | 4 ^{*2} |
| Max. capacity allowable connected outdoor units | 224 kW (80 HP) |
| Max. connectable indoor units | 64 ^{*1} |
| Max. allowable indoor/outdoor capacity ratio | 50-130 % ^{*3} |

*1: In the case of 38 HP or smaller units, the number is limited by the total capacity of the connected indoor units.
 *2: Up to 4 units can be connected if the system has been extended.
 *3: If the following conditions are satisfied, the effective range is above 130 % and below 200 %.
 i) Obey the limited number of connectable indoor units.
 ii) The lower limit of operating range for heating outdoor temperature is limited to -10°CWB (standard -25°CWB).
 iii) Simultaneous operation is limited to less than 130 % of connectable indoor units.

Additional refrigerant charge

| Liquid tubing size mm (inches) | Amount of refrigerant charge/m (g/m) |
|--------------------------------|--------------------------------------|
| $\phi 6.35$ ($\phi 1/4$) | 26 |
| $\phi 9.52$ ($\phi 3/8$) | 56 |
| $\phi 12.7$ ($\phi 1/2$) | 128 |
| $\phi 15.88$ ($\phi 5/8$) | 185 |
| $\phi 19.05$ ($\phi 3/4$) | 259 |
| $\phi 22.22$ ($\phi 7/8$) | 366 |
| $\phi 25.4$ ($\phi 1$) | 490 |

Refrigerant piping (Existing piping can be used.)

High Efficiency Combination Model

| Piping size (mm) | | | |
|---------------------|----------------------------|--------------|-------------|
| Material Temper - O | Material Temper - 1/2 H, H | | |
| $\phi 6.35$ | t 0.8 | $\phi 22.22$ | t 1.0 |
| $\phi 9.52$ | t 0.8 | $\phi 25.4$ | t 1.0 |
| $\phi 12.7$ | t 0.8 | $\phi 28.58$ | t 1.0 |
| $\phi 15.88$ | t 1.0 | $\phi 31.75$ | t 1.1 |
| $\phi 19.05$ | t 1.2 | $\phi 38.1$ | over t 1.35 |
| | | $\phi 41.28$ | over t 1.45 |
| | | $\phi 44.45$ | over t 1.55 |

Space Saving Combination Model

| Piping size (mm) | | | |
|---------------------|----------------------------|--------------|-------------|
| Material Temper - O | Material Temper - 1/2 H, H | | |
| $\phi 6.35$ | t 0.8 | $\phi 22.22$ | t 1.0 |
| $\phi 9.52$ | t 0.8 | $\phi 25.4$ | t 1.0 |
| $\phi 12.7$ | t 0.8 | $\phi 28.58$ | t 1.0 |
| $\phi 15.88$ | t 1.0 | $\phi 31.75$ | t 1.1 |
| $\phi 19.05$ | t 1.2 | $\phi 38.1$ | over t 1.35 |
| | | $\phi 41.28$ | over t 1.45 |
| | | $\phi 44.45$ | over t 1.55 |
| | | $\phi 50.8$ | over t 1.8 |

* When bending the tubes, use a bending radius that is at least 4 times the outer diameter of the tubes. In addition, take sufficient care to avoid crushing or damaging the tubes when bending them.



Refrigerant Branch Pipes (optional accessories) for 2-WAY ME2 Series

Optional Distribution Joint Kits

See the installation instructions packaged with the distribution joint kit for the installation procedure.

* In case the total capacity of indoor units connected after distribution exceeds the total capacity of the outdoor units, select the distribution tubing size for the total capacity of the outdoor units.

| Model name | Cooling capacity after distribution | Remarks |
|----------------|-------------------------------------|------------------|
| 1. CZ-P680PJ2 | 68.0 kW or less | For outdoor unit |
| 2. CZ-P1350PJ2 | more than 68.0 kW | For outdoor unit |
| 3. CZ-P160BK2 | 22.4 kW or less * | For indoor unit |
| 4. CZ-P680BK2 | 68.0 kW or less * | For indoor unit |
| 5. CZ-P1350BK2 | more than 68.0 kW * | For indoor unit |

Tubing size (with thermal insulation)

1. CZ-P680PJ2

For outdoor unit (Capacity after distribution joint is 68.0 kW or less.)

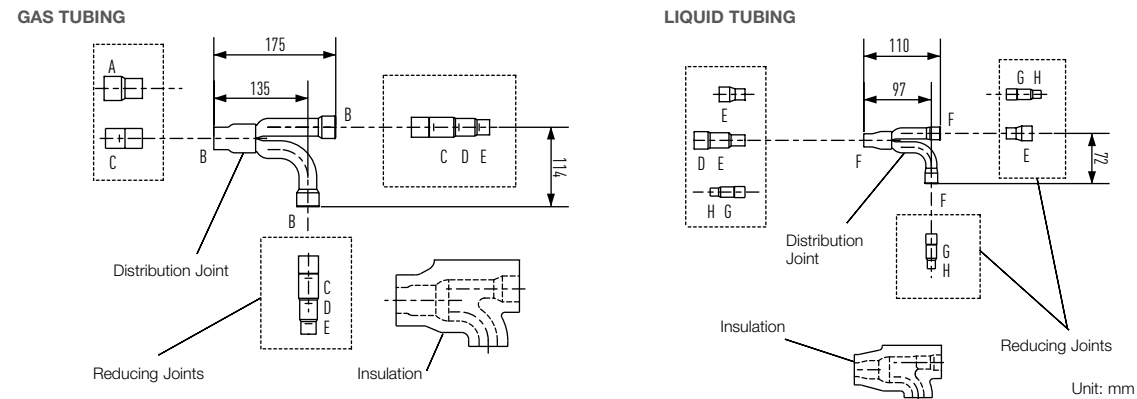

| Size of connection point on each part (Shown are inside diameters of tubing) | | | | | | | | |
|--|--------|--------|--------|--------|--------|--------|--------|--------|
| Size | Part A | Part B | Part C | Part D | Part E | Part F | Part G | Part H |
| Dimension (mm) | ø31.75 | ø28.58 | ø25.40 | ø22.22 | ø19.05 | ø15.88 | ø12.70 | ø9.52 |
| Dimension (inches) | Ø1-1/4 | Ø1-1/8 | Ø1 | Ø7/8 | Ø3/4 | Ø5/8 | Ø1/2 | Ø3/8 |

2. CZ-P1350PJ2

For outdoor unit (Capacity after distribution joint is more than 68.0 kW.)

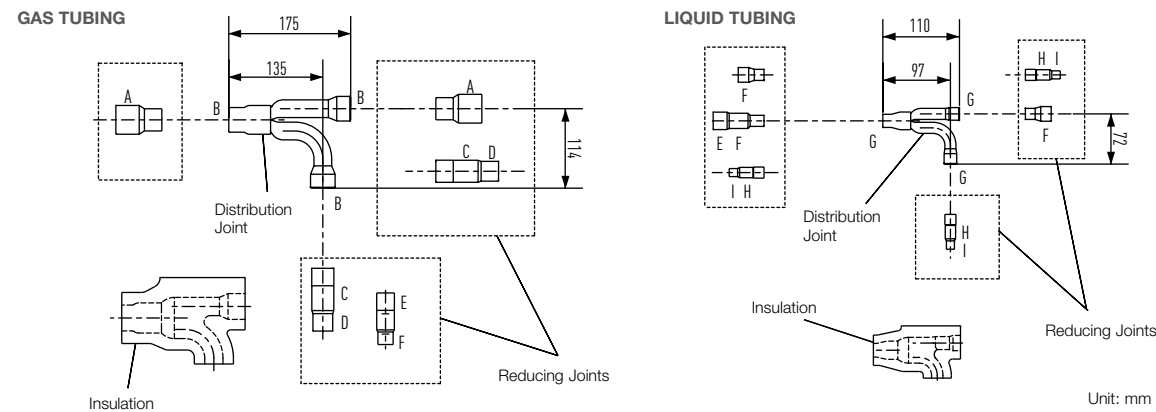

| Size of connection point on each part (Shown are inside diameters of tubing) | | | | | | | | | |
|--|--------|--------|--------|--------|--------|--------|--------|--------|--------|
| Size | Part A | Part B | Part C | Part D | Part E | Part F | Part G | Part H | Part I |
| Dimension (mm) | ø38.10 | ø31.75 | ø28.58 | ø25.40 | ø22.22 | ø19.05 | ø15.88 | ø12.70 | ø9.52 |
| Dimension (inches) | Ø1-1/2 | Ø1-1/4 | Ø1-1/8 | Ø1 | Ø7/8 | Ø3/4 | Ø5/8 | Ø1/2 | Ø3/8 |

* If the tube diameter is more than ø38.1, use field-supply reducer.

3. CZ-P160BK2

Use: For indoor unit (Capacity after distribution joint is 22.4 kW or less.)*

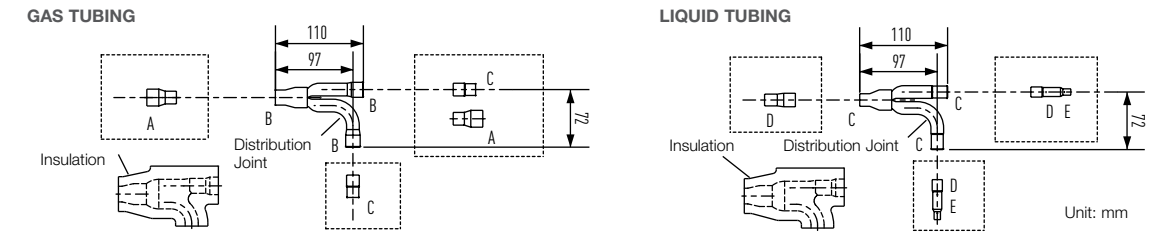

| Size of connection point on each part (Shown are inside diameters of tubing) | | | | | |
|--|--------|--------|--------|--------|--------|
| Size | Part A | Part B | Part C | Part D | Part E |
| Dimension (mm) | Ø19.05 | Ø15.88 | Ø12.70 | Ø9.52 | Ø6.35 |
| Dimension (inches) | Ø3/4 | Ø5/8 | Ø1/2 | Ø3/8 | Ø1/4 |

4. CZ-P680BK2

Use: For indoor unit (Capacity after distribution joint is more than 22.4 kW and no more than 68.0 kW.)*

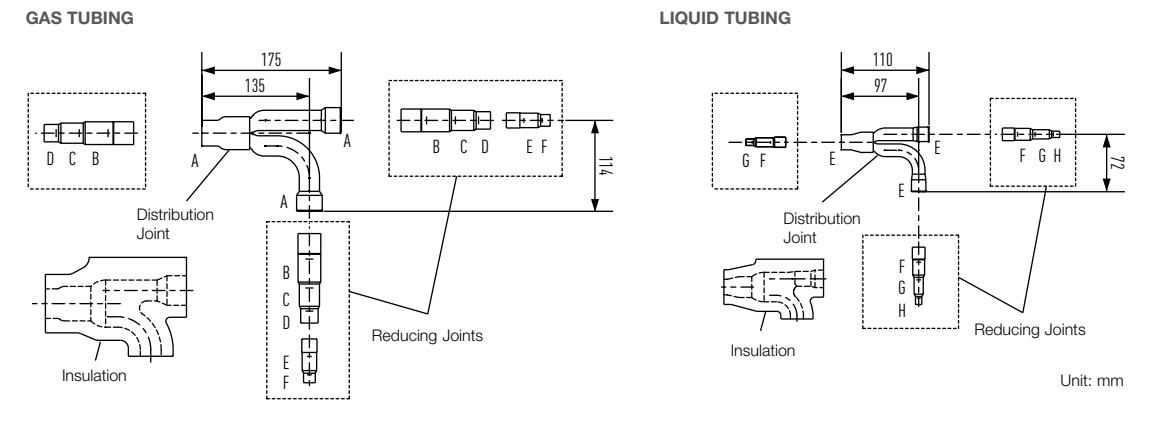

| Size of connection point on each part (Shown are inside diameters of tubing) | | | | | | | | |
|--|--------|--------|--------|--------|--------|--------|--------|--------|
| Size | Part A | Part B | Part C | Part D | Part E | Part F | Part G | Part H |
| Dimension (mm) | Ø28.58 | Ø25.40 | Ø22.22 | Ø19.05 | Ø15.88 | Ø12.70 | Ø9.52 | Ø6.35 |
| Dimension (inches) | Ø1-1/8 | Ø1 | Ø7/8 | Ø3/4 | Ø5/8 | Ø1/2 | Ø3/8 | Ø1/4 |

5. CZ-P1350BK2

Use: For indoor unit (Capacity after distribution joint is more than 68.0 kW.)*

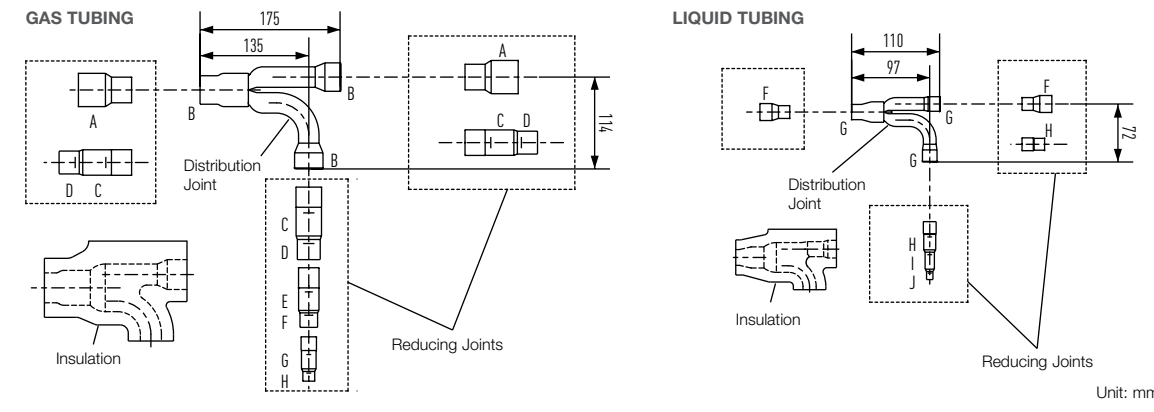

| Size of connection point on each part (Shown are inside diameters of tubing) | | | | | | | | | | |
|--|--------|--------|--------|--------|--------|--------|--------|--------|--------|--------|
| Size | Part A | Part B | Part C | Part D | Part E | Part F | Part G | Part H | Part I | Part J |
| Dimension (mm) | Ø38.10 | Ø31.75 | Ø28.58 | Ø25.40 | Ø22.22 | Ø19.05 | Ø15.88 | Ø12.70 | Ø9.52 | Ø6.35 |
| Dimension (inches) | Ø1-1/2 | Ø1-1/4 | Ø1-1/8 | Ø1 | Ø7/8 | Ø3/4 | Ø5/8 | Ø1/2 | Ø3/8 | Ø1/4 |

*If the tube diameter is more than ø38.1, use field-supply reducer.

* In case the total capacity of indoor units connected after distribution exceeds the total capacity of the outdoor units, select the distribution tubing size for the total capacity of the outdoor units.

2-WAY Mini-FSV LE Series

High External Static Pressure 35Pa



Long piping design length for greater design flexibility

LE1 LE2

Adaptable to various building types and sizes

Actual piping length 150m (equivalent piping length 175m)

Max. total piping length: 300m

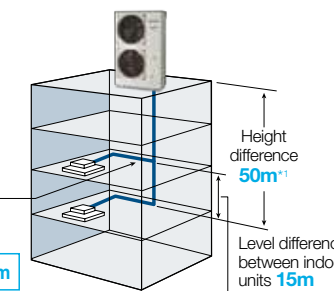

LE 1

Actual piping length 150m (equivalent piping length 175m)

Max. total piping length: 180m

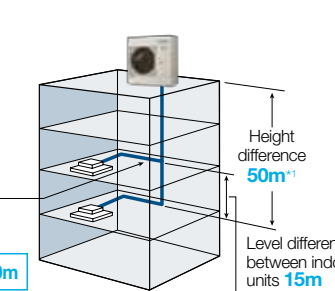

LE 2

*1: 40m if the outdoor unit is below the indoor unit.

Refrigerant chargeless up to 50m

LE2

Up to 50m of piping without additional gas charging makes installation flexible, easy and hassle-free.

A 50m pipe length is sufficient for most residential and small business buildings. When total piping length exceeds 50m, additional refrigerant charge is required.

Chargeless
Max. total piping length: 50m

Charge
Max. total piping length: 180m (Actual length: 150m)

[Sample piping lay-out]

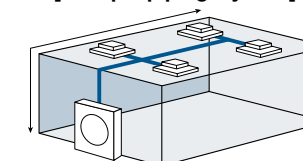

High external static pressure 35Pa

LE1 LE2

When unit is installed on a narrow balcony and exposed to the sun, the fence at the front side would restrict hot air from being discharged. Heat accumulated in an enclosure can cause over-heating. This could potentially result in damage or shorten the product's life span. A high external static pressure sends the air further away from the outdoor unit and through the fence. This provides better air circulation and distribution.



Previous model - Low pressure

When the pressure is low, hot air will accumulate in the unit thus affecting its work performance and of the unit above it as well.

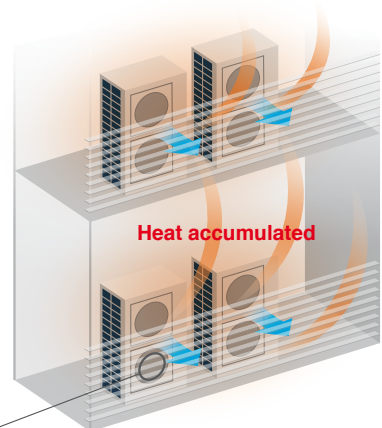

Previous fan

High electrostatic pressure disrupted the airflow of the previous fan, lowering the air pressure and preventing hot air from being discharged far enough.



LE series - High pressure

But with a high pressure of 35Pa, hot air is sent further away preventing overheating inside the outdoor unit enclosure.

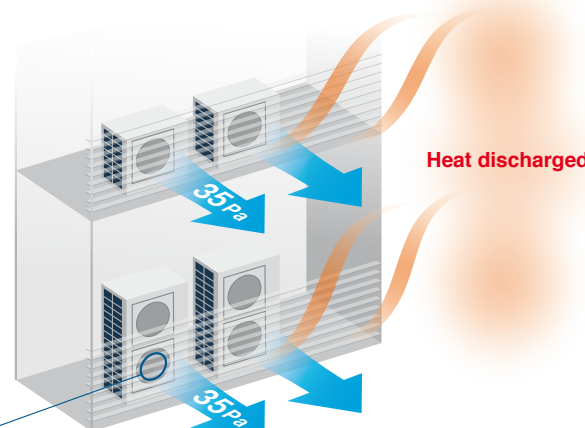

LE series fan

The new LE Series fan has ribs extending near the blade tips, in a structure that resists deformation. During high electrostatic pressure, this blade shape suppresses disruptions in the airflow, and a high air pressure of 35 Pa discharges the hot air a sufficient distance.



Compact design

LE1 LE2

Also, since Mini VRF LE Series is a single unit, it is possible to install the unit in more various places compared to the Single Split system.

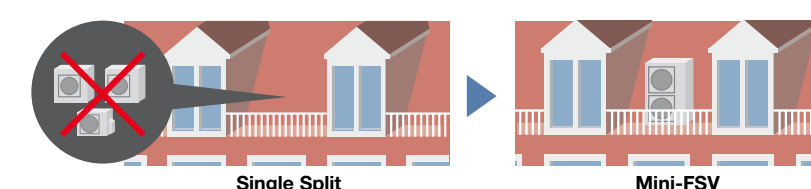

Short height of 996mm

LE2

In addition to raising efficiency, we have made the outdoor unit more compact. It can now be installed in places that were previously too small.

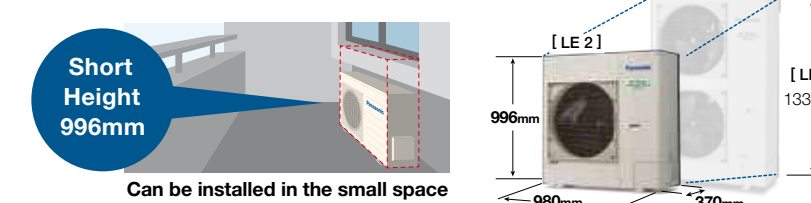

Up to 13 indoor units connectable

LE1 LE2

An expansion from Panasonic VRF line up, the mini FSV is compatible with the same indoor units and controls as the rest of the FSV range.



* Use any of the 22 type indoor models. Depending on the size or type of indoor unit, tubing size shall be changed. Please refer manuals for details.
* Diversity ration 50-130%
* 6 HP only; 4 HP for 7 units, 5 HP for 8 units.

2-WAY Mini-FSV LE Series

High efficiency

LE1 LE2

The operation efficiency has been improved using highly efficient R410A refrigerant, a DC Inverter compressor, DC motor and a heat exchanger design.

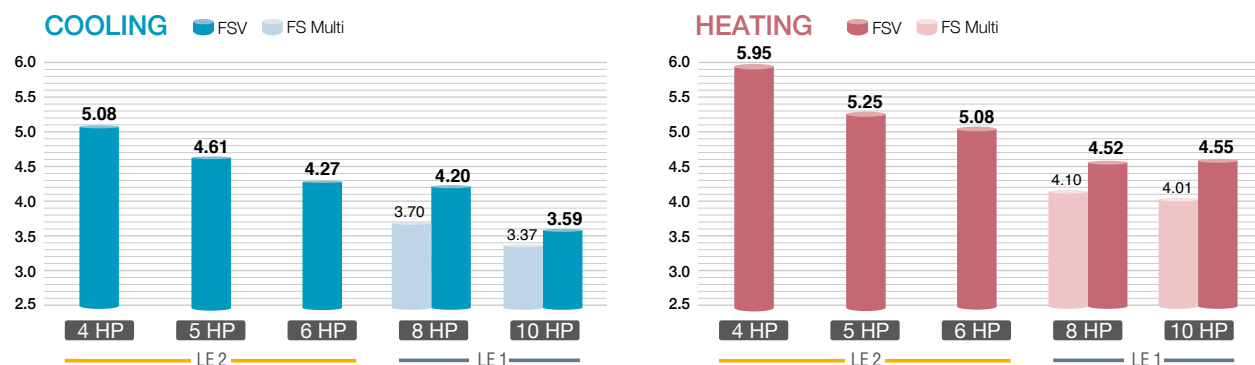

Energy savings design

LE1 LE2

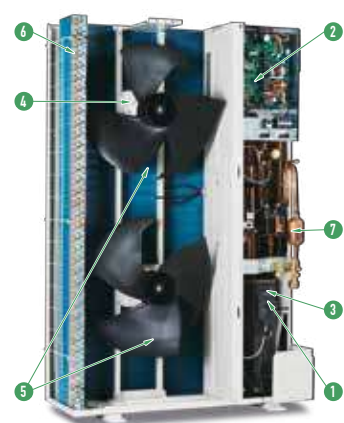

- 1 Panasonic Inverter Compressor**
A large-capacity inverter compressor has been adopted. The inverter compressor is superior in performance with improved partial-load capacity.
- 2 Printed Circuit Board**
The number of PCB is 2 pieces for making maintenance easier.
- 3 Accumulator**
A large accumulator has been adopted to maintain compressor reliability because of the increased refrigerant quantity, which allows an extended max piping length.
- 4 DC Fan Motor**
Checking load and outside temperature, the DC motor is controlled for optimum air volume.
- 5 Newly Designed Fan**
The newly designed fan blades have been developed to inhibit air turbulence and to increase efficiency. As fan diameter has been increased its size, the air volume has been increased whilst maintaining a same sound level.
- 6 Heat Exchanger & Copper Tubes**
The heat exchanger size and the copper tube sizes in the heat exchanger have been redesigned to increase efficiency.
- 7 Oil Separator**
A centrifugal separator has been adopted to improve oil separation efficiency and reduce refrigerant pressure loss.

Flexible demand response with the optional terminal block

LE1 LE2

Demand Response

Featuring inverter control technology, all Panasonic Mini FSV systems are Demand Response Management (DRM) ready. With this control, power consumption at times of peak load can be set in three steps to deliver optimum performance. This helps to reduce annual power consumption with minimal loss in comfort.

*Terminal block parts to be supplied separately. Please ask your dealer.

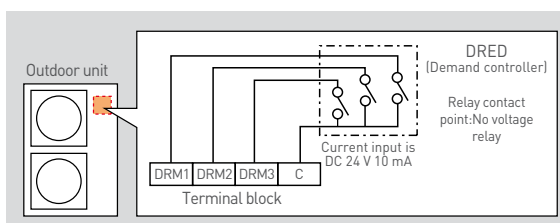

Flexible Demand Response with the CZ-CAPDC2^{*1}

Setting is possible as 0% or in the range from 40 to 100% (in steps of 5%). At the time of shipping, setting has been done to the three steps of 0%, 70% and 100%.

^{*1} An outdoor Seri-Para I/O unit (CZ-CAPDC2) is required for demand input signal.
* Demand timer setting for high spec remote controller is available.

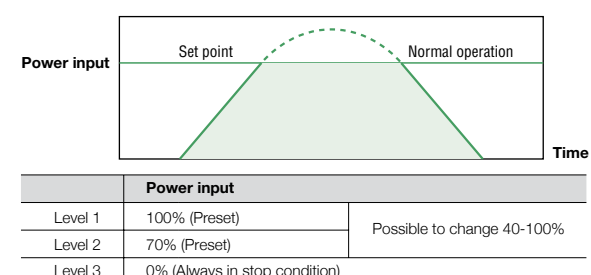

Wide operating range

LE1 LE2

- Cooling operation is possible even when outdoor temperature is as low as -10°C DB.
- Cooling operation is possible even when outdoor temperature is as high as 46°C DB.
- Heating operation is possible even when outdoor temperature is as low as -20°C WB.

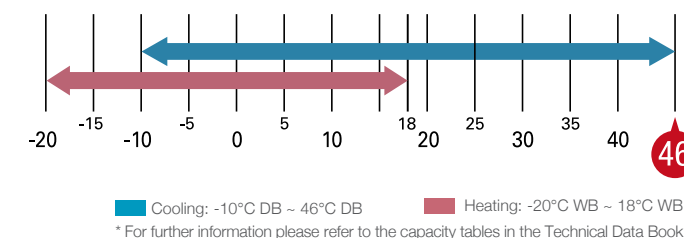

The remote controller temperature can be set from 18°C up to 30°C (Cooling), 16°C up to 30°C (Heating)*1.
*1 Depending on the type of remote controller.

Blue fin condenser

LE1 LE2

The anti-corrosion Blue Fin treatment of the heat exchanger provides greater resistance against corrosion. All models are equipped with Blue Fin condenser.

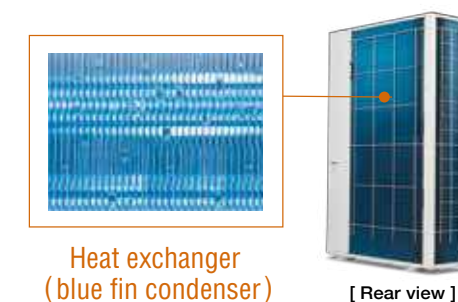

High durability outdoor unit

LE1 LE2

Corrosion-resistance treated for high resistance to rust and salty air to assure long-lasting performance.

Note: Selecting this unit does not completely eliminate the possibility of rust developing. For details concerning unit installation and maintenance, please consult an authorised dealer.

* Specific model with suffix "E" has this treatment.

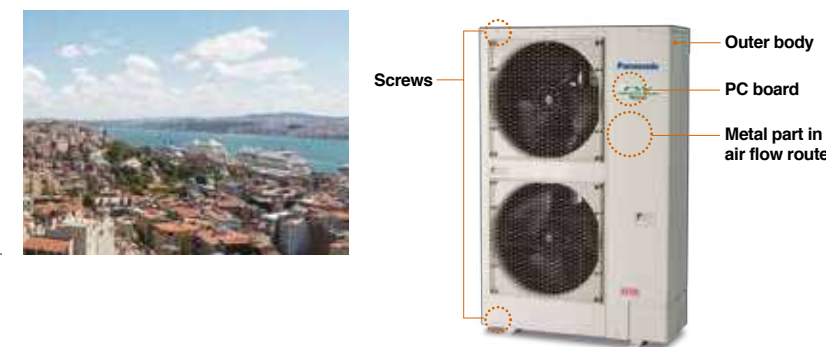

Quiet operation mode

LE1 LE2

- Quiet operation mode reduces outdoor unit operating sound down to 7dB than rating.
- 3-step set point is available.
- External input signal is also available.

* Timer setting of quiet operation mode is available in High-spec Remote Controller (CZ-RTC6).



2-WAY Mini-FSV LE2 Series

| HP | 4 | | | 5 | | | 6 | | | | | | | | | | | | | | | | | | | | | | | | | | | | | | | | | | | | | | | | | | | | | | | | | | | | |
|-------------------------------------|--|-------------------------|-------------------|--|-------------------|-----------------|--|-----------------|-----------------|--|------|--------------------|--|------|--|--|------|-----------------|-----------------|--|-----------------|---|--|-------|---|--|-------|--|--|-------|--|--|------|--|--|------|--|--|------|--|--|-------|--|--|-------|--|--|-------|--|--|------|--|--|------|--|--|------|--|--|
| Model name | U-4LE2H4 | | | U-4LE2H7 | | | U-5LE2H4 | | | U-5LE2H7 | | | U-6LE2H4 | | | U-6LE2H7 | | | | | | | | | | | | | | | | | | | | | | | | | | | | | | | | | | | | | | | | | | | |
| Power supply | 220/230/240V/1-phase/50Hz 220/230V/1-phase/60Hz | | | 380/400/415V/3-phase/50Hz 380/400V/3-phase/60Hz | | | 220/230/240V/1-phase/50Hz 220/230V/1-phase/60Hz | | | 380/400/415V/3-phase/50Hz 380/400V/3-phase/60Hz | | | 220/230/240V/1-phase/50Hz 220/230V/1-phase/60Hz | | | 380/400/415V/3-phase/50Hz 380/400V/3-phase/60Hz | | | | | | | | | | | | | | | | | | | | | | | | | | | | | | | | | | | | | | | | | | | |
| Voltage | 220V | 230V | 240V | 380V | 400V | 415V | 220V | 230V | 240V | 380V | 400V | 415V | 220V | 230V | 240V | 380V | 400V | 415V | | | | | | | | | | | | | | | | | | | | | | | | | | | | | | | | | | | | | | | | | |
| Capacity | Cooling | | kW | | | 12.1 | | | 12.1 | | | 14.0 | | | 14.0 | | | 15.5 | | | 15.5 | | | | | | | | | | | | | | | | | | | | | | | | | | | | | | | | | | | | | | |
| | Heating | | kW | | | 12.5 | | | 12.5 | | | 16.0 | | | 16.0 | | | 16.5 | | | 16.5 | | | | | | | | | | | | | | | | | | | | | | | | | | | | | | | | | | | | | | |
| EER/COP | Cooling | | W/W | | | 5.08 | | | 5.08 | | | 4.61 | | | 4.61 | | | 4.27 | | | 4.27 | | | | | | | | | | | | | | | | | | | | | | | | | | | | | | | | | | | | | | |
| | Heating | | W/W | | | 5.95 | | | 5.95 | | | 5.25 | | | 5.25 | | | 5.08 | | | 5.08 | | | | | | | | | | | | | | | | | | | | | | | | | | | | | | | | | | | | | | |
| Dimensions H x W x D | mm | | | 996 x 980 x 370 | | | 996 x 980 x 370 | | | 996 x 980 x 370 | | | 996 x 980 x 370 | | | 996 x 980 x 370 | | | 996 x 980 x 370 | | | | | | | | | | | | | | | | | | | | | | | | | | | | | | | | | | | | | | | | |
| Net weight | kg | | | 106 | | | 106 | | | 106 | | | 106 | | | 106 | | | 106 | | | | | | | | | | | | | | | | | | | | | | | | | | | | | | | | | | | | | | | | |
| Electrical ratings | Cooling | Running current | A | | | 11.90 | | | 11.40 | | | 10.90 | | | 3.89 | | | 3.69 | | | 3.56 | | | 15.20 | | | 14.50 | | | 13.90 | | | 4.91 | | | 4.67 | | | 4.50 | | | 18.10 | | | 17.30 | | | 16.60 | | | 5.87 | | | 5.57 | | | 5.37 | | |
| | | Power input | kW | | | 2.38 | | | 2.38 | | | 2.38 | | | 2.38 | | | 3.04 | | | 3.04 | | | 3.04 | | | 3.04 | | | 3.04 | | | 3.63 | | | 3.63 | | | 3.63 | | | 3.63 | | | 3.63 | | | 3.63 | | | | | | | | | | | |
| | Heating | Running current | A | | | 10.60 | | | 10.10 | | | 9.70 | | | 3.47 | | | 3.29 | | | 3.18 | | | 15.20 | | | 14.60 | | | 14.0 | | | 4.93 | | | 4.68 | | | 4.51 | | | 16.20 | | | 15.50 | | | 14.90 | | | 5.25 | | | 4.99 | | | 4.81 | | |
| | | Power input | kW | | | 2.10 | | | 2.10 | | | 2.10 | | | 2.10 | | | 2.10 | | | 3.05 | | | 3.05 | | | 3.05 | | | 3.05 | | | 3.05 | | | 3.25 | | | 3.25 | | | 3.25 | | | 3.25 | | | 3.25 | | | 3.25 | | | | | | | | |
| Starting current | A | | | 1 | | | 1 | | | 1 | | | 1 | | | 1 | | | 1 | | | 1 | | | 1 | | | | | | | | | | | | | | | | | | | | | | | | | | | | | | | | | | |
| Air flow rate | m ³ / min | | | 69 | | | 69 | | | 72 | | | 72 | | | 74 | | | 74 | | | | | | | | | | | | | | | | | | | | | | | | | | | | | | | | | | | | | | | | |
| | L/s | | | 1,150 | | | 1,150 | | | 1,200 | | | 1,200 | | | 1,233 | | | 1,233 | | | | | | | | | | | | | | | | | | | | | | | | | | | | | | | | | | | | | | | | |
| Refrigerant amount at shipment | kg | | | R410A 6.70 | | | R410A 6.70 | | | R410A 6.70 | | | R410A 6.70 | | | R410A 6.70 | | | R410A 6.70 | | | | | | | | | | | | | | | | | | | | | | | | | | | | | | | | | | | | | | | | |
| Piping connection | Gas pipe | | mm (inches) | | | Ø15.88 (Ø5/8) | | | Ø15.88 (Ø5/8) | | | Ø15.88 (Ø5/8) | | | Ø15.88 (Ø5/8) | | | Ø15.88 (Ø5/8) | | | Ø15.88 (Ø5/8) | | | | | | | | | | | | | | | | | | | | | | | | | | | | | | | | | | | | | | |
| | Liquid pipe | | mm (inches) | | | Ø9.52 (Ø3/8) | | | Ø9.52 (Ø3/8) | | | Ø9.52 (Ø3/8) | | | Ø9.52 (Ø3/8) | | | Ø9.52 (Ø3/8) | | | Ø9.52 (Ø3/8) | | | | | | | | | | | | | | | | | | | | | | | | | | | | | | | | | | | | | | |
| Ambient temperature operating range | Cooling | | -10°CDB~+46°CDB | | | -10°CDB~+46°CDB | | | -10°CDB~+46°CDB | | | -10°CDB~+46°CDB | | | -10°CDB~+46°CDB | | | -10°CDB~+46°CDB | | | -10°CDB~+46°CDB | | | | | | | | | | | | | | | | | | | | | | | | | | | | | | | | | | | | | | |
| | Heating | | -20°CWB~+18°CWB | | | -20°CWB~+18°CWB | | | -20°CWB~+18°CWB | | | -20°CWB~+18°CWB | | | -20°CWB~+18°CWB | | | -20°CWB~+18°CWB | | | -20°CWB~+18°CWB | | | | | | | | | | | | | | | | | | | | | | | | | | | | | | | | | | | | | | |
| Sound pressure level (Cooling) | Normal mode | | dB(A) | | | 52.0 | | | 52.0 | | | 53.0 | | | 53.0 | | | 54.0 | | | 54.0 | | | | | | | | | | | | | | | | | | | | | | | | | | | | | | | | | | | | | | |
| | Silent mode (3) | | dB(A) | | | 45.0 | | | 45.0 | | | 46.0 | | | 46.0 | | | 47.0 | | | 47.0 | | | | | | | | | | | | | | | | | | | | | | | | | | | | | | | | | | | | | | |
| Sound power level (Cooling) | Normal mode | | dB | | | 69.0 | | | 69.0 | | | 71.0 | | | 71.0 | | | 73.0 | | | 73.0 | | | | | | | | | | | | | | | | | | | | | | | | | | | | | | | | | | | | | | |
| | Global remarks | | Rated conditions: | | | Cooling | | | Heating | | | * As a foot print. | | | ** High durable model (with suffix "E") has same specifications. | | | | | | | | | | | | | | | | | | | | | | | | | | | | | | | | | | | | | | | | | | | | |
| | | Indoor air temperature | | | 27°C DB / 19°C WB | | | 20°C DB | | | | | | | | | | | | | | | | | | | | | | | | | | | | | | | | | | | | | | | | | | | | | | | | | | | |
| | | Outdoor air temperature | | | 35°C DB | | | 7°C DB / 6°C WB | | | | | | | | | | | | | | | | | | | | | | | | | | | | | | | | | | | | | | | | | | | | | | | | | | | |

Dimensions U-4LE2H4 / U-4LE2H7 U-5LE2H4 / U-5LE2H7 U-6LE2H4 / U-6LE2H7

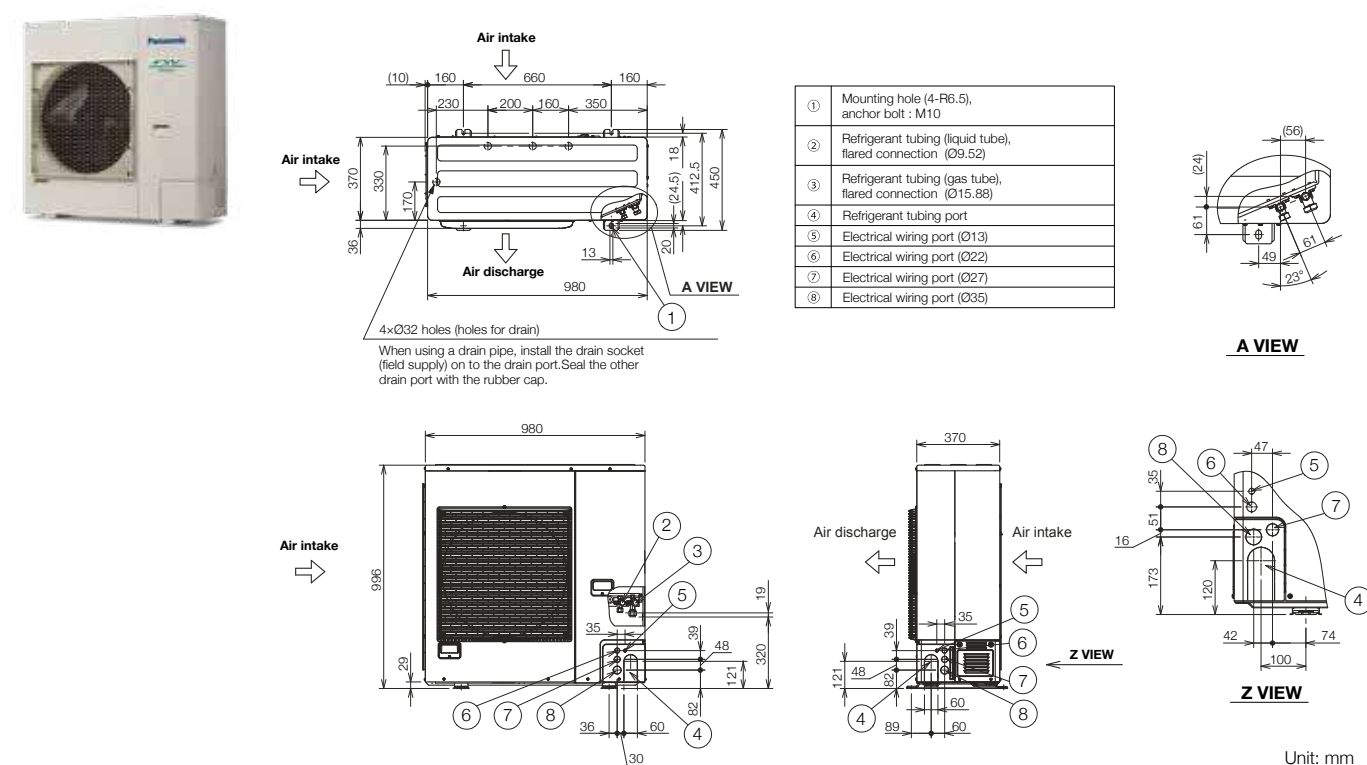

2-WAY Mini-FSV LE1 Series

| HP | 8 | | | 10 | | | | | | | | | | | | | | | | | | | |
|-------------------------------------|--|-------------------------|-------------------|--|-------------------|---------------|-------------------|-----------------|---------------|---|--|--------------------|--|--|--|--|--|------|--|--|------|--|--|
| Model name | U-8LE1H7 | | | U-10LE1H7 | | | | | | | | | | | | | | | | | | | |
| Power supply | 380/400/415V/3-phase/50Hz 380/400V/3-phase/60Hz | | | 380/400/415V/3-phase/50Hz 380/400V/3-phase/60Hz | | | | | | | | | | | | | | | | | | | |
| Voltage | 380V | 400V | 415V | 380V | 400V | 415V | | | | | | | | | | | | | | | | | |
| Capacity | Cooling | | kW | | | 22.4 | | | 28.0 | | | | | | | | | | | | | | |
| | Heating | | kW | | | 25.0 | | | 28.0 | | | | | | | | | | | | | | |
| EER/COP | Cooling | | W/W | | | 4.20 | | | 3.59 | | | | | | | | | | | | | | |
| | Heating | | W/W | | | 4.52 | | | 4.55 | | | | | | | | | | | | | | |
| Dimensions (H/W/D) | mm | | | 1,500 x 980 x 370 | | | 1,500 x 980 x 370 | | | | | | | | | | | | | | | | |
| Net weight | kg | | | 132 | | | 133 | | | | | | | | | | | | | | | | |
| Electrical ratings | Cooling | Running current | A | | | 8.70 | | | 8.25 | | | 7.95 | | | 12.7 | | | 12.1 | | | 11.7 | | |
| | | Power input | kW | | | 5.33 | | | 5.33 | | | 5.33 | | | 7.8 | | | 7.80 | | | 7.80 | | |
| | Heating | Running current | A | | | 9.05 | | | 8.60 | | | 8.25 | | | 10.0 | | | 9.55 | | | 9.20 | | |
| | | Power input | kW | | | 5.53 | | | 5.53 | | | 5.53 | | | 6.15 | | | 6.15 | | | 6.15 | | |
| Starting current | A | | | 1 | | | 1 | | | 1 | | | | | | | | | | | | | |
| Air flow rate | m ³ / min | | | 150 | | | 160 | | | | | | | | | | | | | | | | |
| | L/s | | | 2,500 | | | 2,666 | | | | | | | | | | | | | | | | |
| Refrigerant amount at shipment | kg | | | R410A 6.30 | | | R410A 6.60 | | | | | | | | | | | | | | | | |
| Piping connection | Gas pipe | | mm (inches) | | | Ø19.05 (Ø3/4) | | | Ø22.22 (Ø7/8) | | | | | | | | | | | | | | |
| | Liquid pipe | | mm (inches) | | | Ø9.52 (Ø3/8) | | | Ø9.52 (Ø3/8) | | | | | | | | | | | | | | |
| Ambient temperature operating range | Cooling: -10°CDB~+46°CDB, Heating: -20°CWB~+18°CWB | | | Cooling: -10°CDB~+46°CDB, Heating: -20°CWB~+18°CWB | | | | | | | | | | | | | | | | | | | |
| Sound pressure level (Cooling) | Normal mode | | dB(A) | | | 59.0 | | | 62.0 | | | | | | | | | | | | | | |
| | Silent mode | | dB(A) | | | 52.0 | | | 55.0 | | | | | | | | | | | | | | |
| Sound power level (Cooling) | Normal mode | | dB | | | 80.0 | | | 83.0 | | | | | | | | | | | | | | |
| | Global remarks | | Rated conditions: | | | Cooling | | | Heating | | | * As a foot print. | | | ** High durable model (with suffix "E") has same specifications. | | | | | | | | |
| | | Indoor air temperature | | | 27°C DB / 19°C WB | | | 20°C DB | | | | | | | | | | | | | | | |
| | | Outdoor air temperature | | | 35°C DB | | | 7°C DB / 6°C WB | | | | | | | | | | | | | | | |

Dimensions U-8LE1H7 / U-10LE1H7

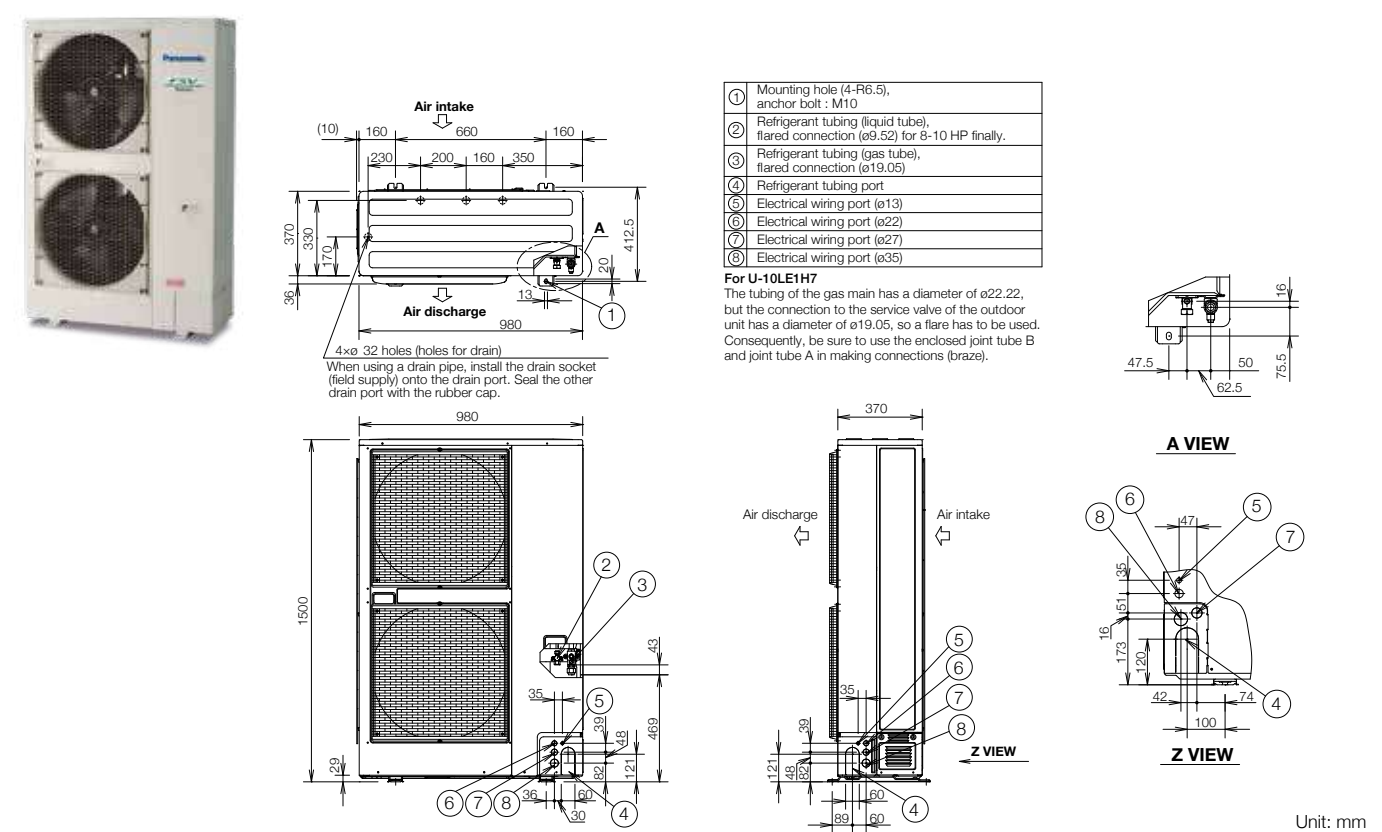

2-WAY Mini-FSV LE2 Series

Distribution Joint Kits

CZ-P160BK2

Use: For indoor unit (Capacity after distribution joint is 22.4 kW or less.)*

* In case the total capacity of indoor units connected after distribution exceeds the total capacity of the outdoor units, select the distribution piping size for the total capacity of the outdoor units.

GAS PIPING

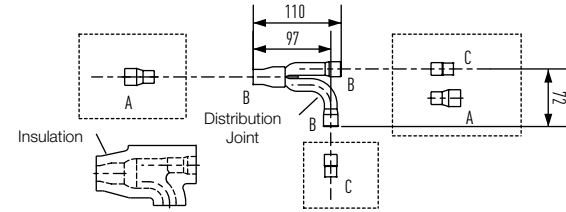

LIQUID PIPING

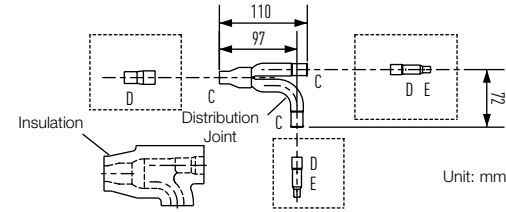

Unit: mm

| Size of connection point on each part (Shown are inside diameters of piping) | | | | | |
|--|--------|--------|--------|--------|--------|
| Size | Part A | Part B | Part C | Part D | Part E |
| Dimension (mm) | Ø19.05 | Ø15.88 | Ø12.70 | Ø9.52 | Ø6.35 |
| (inches) | Ø3/4 | Ø5/8 | Ø1/2 | Ø3/8 | Ø1/4 |

Wiring System Diagrams (LE2/LE1)

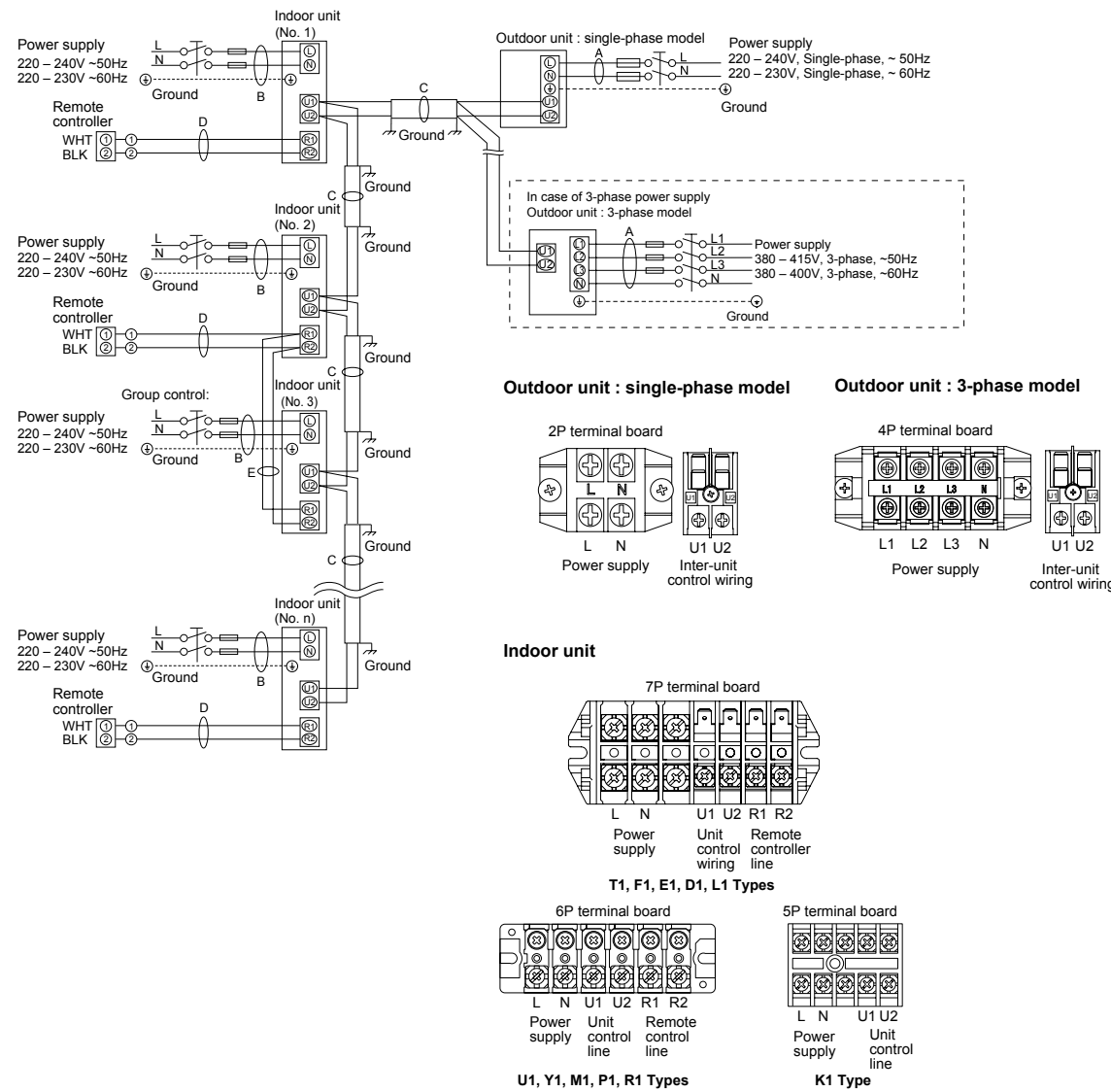
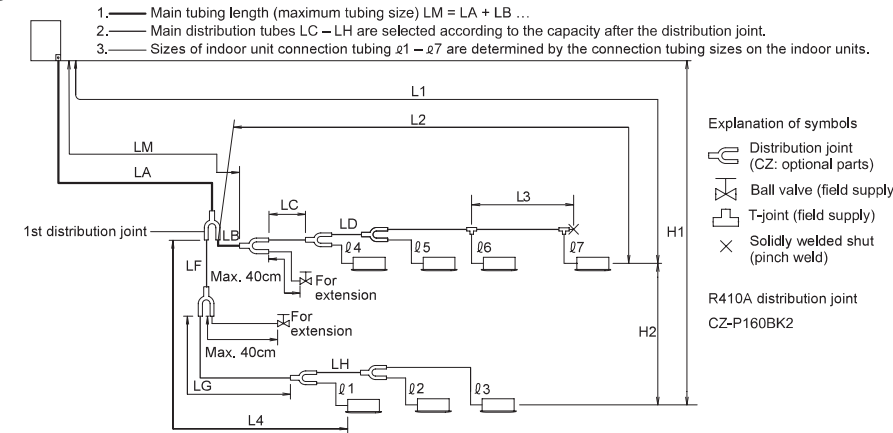

Fig. 2-1

Piping Design

Select the installation location so that the length and size of refrigerant piping are within the allowable range shown in the figure below.



- Explanation of symbols
- Distribution joint (CZ: optional parts)
 - Ball valve (field supply)
 - T-joint (field supply)
 - Solidly welded shut (pinch weld)

R410A distribution joint
CZ-P160BK2

Ranges that Apply to Refrigerant Piping Lengths and to Differences in Installation Heights

| Items | Mark | Contents | Length (m) | |
|----------------------------------|------------------------|--|---------------|-------------------|
| | | | Actual length | Equivalent length |
| Allowable piping length | L1 | Max. piping length | ≤150 | — |
| | ΔL (L2 - L4) | Difference between max. length and min. length from the 1st distribution joint | ≤175 | — |
| | LM | Max. length of main piping (at maximum size) *Even after 1st distribution joint, LM is allowed if at maximum piping length. | — | — |
| | ℓ1, ℓ2- ℓ7 | Max. length of each distribution pipe | ≤50 | — |
| | L1+ℓ1+ℓ2- ℓ6 + LF + LG | Total max. piping length including length of each distribution pipe (only liquid piping) | ≤180 | — |
| Allowable elevation difference | H1 | When outdoor unit is installed higher than indoor unit | ≤50 | — |
| | H2 | When outdoor unit is installed lower than indoor unit | ≤40 | — |
| Allowable length of joint piping | L3 | T-joint piping (field-supply); Max. piping length between the first T-joint and solidly welded-shut end point | ≤15 | — |
| | L3 | T-joint piping (field-supply); Max. piping length between the first T-joint and solidly welded-shut end point | ≤2 | — |

L = Length, H = Height

Piping Size

Main Piping Size (LA)

| | 12.1 kW | 14.0 kW | 15.5 kW |
|---------------------------|---------------|---------|---------|
| Gas tubing mm (inches) | ø15.88 (ø5/8) | — | — |
| Flare connection | — | — | — |
| Liquid tubing mm (inches) | ø9.52 (ø3/8) | — | — |
| Flare connection | — | — | — |

Note :The refrigerant piping should be used with R410A refrigerant.

Main Piping Size After Distribution (LB, LC...)

| Total capacity after distribution | Below kW | | 7.1 (2.5HP) | |
|-----------------------------------|---------------|----------|-------------|--------|
| | Over kW | | — | |
| Piping size | Gas piping | (mm) | ø12.7 | ø15.88 |
| | | (inches) | ø1/2 | ø5/8 |
| | Liquid piping | (mm) | ø9.52 | ø9.52 |
| | | (inches) | ø3/8 | ø3/8 |

Indoor Unit Piping Connection (ℓ1, ℓ2...ℓn-1)

| Indoor unite type | 22 | 28 | 36 | 45 | 56 | 60 | 71/73 | 90 | 106 | 140 | 160 | |
|---------------------------|--------------|----|----|----|----|---------------|-------|----|-----|-----|-----|--|
| Gas piping mm (inches) | ø12.7 (ø1/2) | | | | | ø15.88 (ø5/8) | | | | | | |
| Liquid piping mm (inches) | ø6.35 (ø1/4) | | | | | ø9.52 (ø3/8) | | | | | | |

Note: In case the total capacity of indoor units connected after distribution exceeds the capacity of the outdoor unit, select the main piping size for the capacity of the outdoor unit.

System Limitations

| Outdoor units | 12.1 kW | 14.0 kW | 15.5 kW |
|--|-----------|---------|---------|
| Number of max. connectable indoor units | 7 | 8 | 9 |
| Max. allowable indoor/outdoor capacity ratio | 50 - 130% | | |

kW = kilowatts

2-WAY Mini-FSV LE1 Series

Distribution Joint Kits

CZ-P160BK2

Use: For indoor unit (Capacity after distribution joint is 22.4 kW or less.)*

* In case the total capacity of indoor units connected after distribution exceeds the total capacity of the outdoor units, select the distribution piping size for the total capacity of the outdoor units.

GAS PIPING

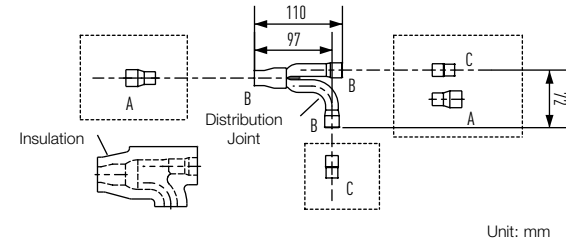

LIQUID PIPING

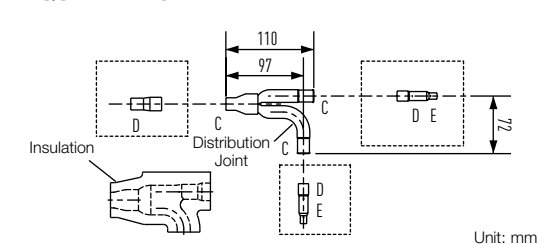

| Size of connection point on each part (Shown are inside diameters of tubing) | | | | | |
|--|--------|--------|--------|--------|--------|
| Size | Part A | Part B | Part C | Part D | Part E |
| Dimension (mm) | Ø19.05 | Ø15.88 | Ø12.70 | Ø9.52 | Ø6.35 |
| (inches) | Ø3/4 | Ø5/8 | Ø1/2 | Ø3/8 | Ø1/4 |

CZ-P680BK2

Use: For indoor unit (Capacity after distribution joint is greater than 22.4 kW and no more than 68.0 kW.)*

* In case the total capacity of indoor units connected after distribution exceeds the total capacity of the outdoor units, select the distribution piping size for the total capacity of the outdoor units.

GAS PIPING

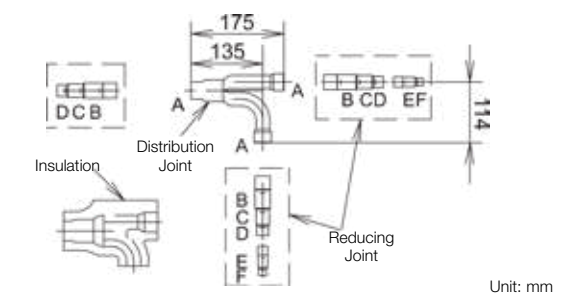

LIQUID PIPING

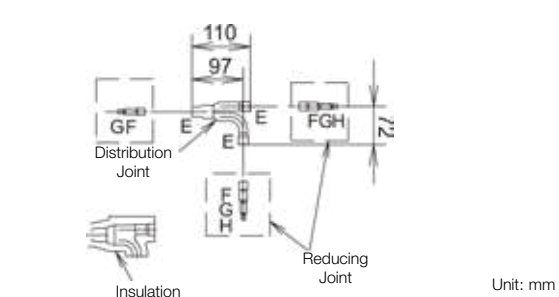

| Size of connection point on each part (Shown are inside diameters of piping) | | | | | | | | |
|--|--------|--------|--------|--------|--------|--------|--------|--------|
| Size | Part A | Part B | Part C | Part D | Part E | Part F | Part G | Part H |
| Dimension (mm) | Ø28.58 | Ø25.4 | Ø22.22 | Ø19.05 | Ø15.88 | Ø12.7 | Ø9.52 | Ø6.35 |
| (inches) | Ø1-1/8 | Ø1 | Ø7/8 | Ø3/4 | Ø5/8 | Ø1/2 | Ø3/8 | Ø1/4 |

Piping design

Select the installation location so that the length and size of refrigerant piping are within the allowable range shown in the figure below.

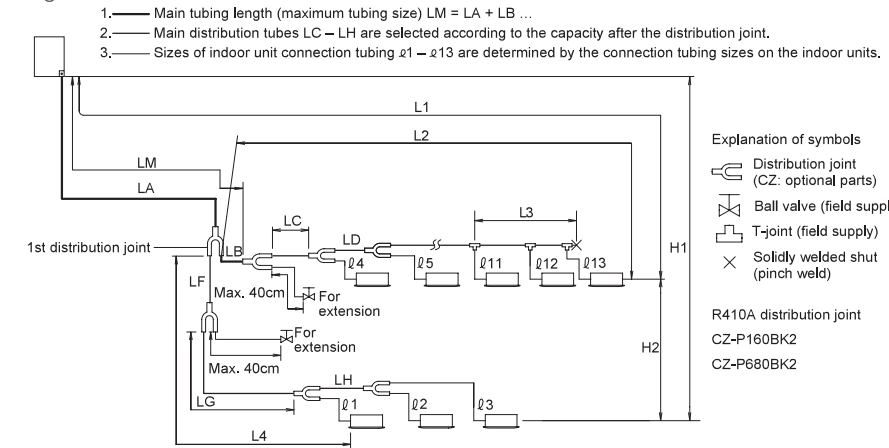

Ranges that Apply to Refrigerant Piping Lengths and to Differences in Installation Heights

| Items | Mark | Contents | Length (m) | |
|----------------------------------|-----------------------------------|--|---------------|-------------------|
| | | | Actual length | Equivalent length |
| Allowable piping length | L1 | Max. piping length | ≤150 | ≤175 |
| | ΔL (L2 - L4) | Difference between max. length and min. length from the 1st distribution joint | ≤50 | |
| | LM | Max. length of main piping (at maximum size) *Even after 1st distribution joint, LM is allowed if at maximum piping length. | — | |
| | ø1, ø2- ø13 | Max. length of each distribution pipe | ≤50 | |
| | L1 + ø1 + ø2 - ø12 + LF + LG + LH | Total max. piping length including length of each distribution pipe (only liquid piping) | ≤300 | |
| Allowable elevation difference | H1 | When outdoor unit is installed higher than indoor unit | ≤50 | |
| | H2 | When outdoor unit is installed lower than indoor unit | ≤40 | |
| Allowable length of joint piping | L3 | Max. difference between indoor units | ≤15 | |
| | | T-joint piping (field-supply); Max. piping length between the first T-joint and solidly welded-shut end point | ≤2 | |

L = Length, H = Height

Piping Size

Main Piping Size (LA)

| | 22.4 kW | 28.0 kW |
|---------------------------|------------------|--------------------|
| Outdoor unit horsepower | 8 HP | 10 HP |
| Gas piping mm (inches) | ø19.05 (ø3/4) | ø22.22 (ø7/4) |
| | Flare connection | Brazing connection |
| Liquid piping mm (inches) | ø9.52 (ø3/8) | |
| | Flare connection | |

Note :If future extension is planned, select the piping diameter based on the total horsepower after extension. The refrigerant piping should be used with R410A refrigerant.

Main Piping Size After Distribution (LB, LC...)

| Total capacity after distribution | Below kW | | | | | |
|-----------------------------------|---------------|-------------|---------------|--------|--------|--------|
| | 7.1 (2.5HP) | 16.0 (6 HP) | 22.5 (8.1 HP) | — | | |
| Over kW | — | | | | | |
| | 7.1 (2.5 HP) | 16.0 (6 HP) | 22.5 (8.1 HP) | — | | |
| Piping size | Gas tubing | (mm) | ø12.7 | ø15.88 | ø19.05 | ø22.22 |
| | | (inches) | ø1/2 | ø5/8 | ø3/4 | ø7/8 |
| | Liquid tubing | (mm) | ø9.52 | ø9.52 | ø9.52 | ø9.52 |
| | | (inches) | ø3/8 | ø3/8 | ø3/8 | ø3/8 |

kW = kilowatts

Note :In case the total capacity of connected indoor units exceeds the total capacity of the outdoor units, select the main piping size for the total capacity of the outdoor units.

Indoor Unit Piping Connection (ø1, ø2...ø13)

| Indoor unit type | 22 | 28 | 36 | 45 | 56 | 60 | 71/73 | 90 | 106 | 140 | 160 | 180 | 224 | 280 | |
|---------------------------|--------------|----|----|----|----|----|---------------|----|-----|---------------|-----|---------------|-----|-----|--|
| Gas tubing mm (inches) | ø12.7 (ø1/2) | | | | | | ø15.88 (ø5/8) | | | ø19.05 (ø3/4) | | ø22.22 (ø7/8) | | | |
| Liquid tubing mm (inches) | ø6.35 (ø1/4) | | | | | | ø9.52 (ø3/8) | | | | | | | | |

System Limitations

| | | |
|--|----------------|-----------------|
| Outdoor units | 22.4 kW (8 HP) | 28.0 kW (10 HP) |
| Number of max. connectable indoor units | 13 | 13 |
| Max. allowable indoor/outdoor capacity ratio | 50 - 130% | |

nanoe™ X Air protection*

While the general filters in air purifiers are effective against airborne bacteria and viruses, nanoe™ X also works to inhibit longer-living, adhered bacteria and viruses.



*Unit must be constantly turned on and operating in the air purification mode - nanoe™ X.
** <https://www.businessinsider.com/coronavirus-lifespan-on-surfaces-graphic-2020-3>

What is unique about nanoe™ X ?



1 Huge Quantity

9.6 trillion hydroxyl radicals are generated per a second, inhibiting bacteria and adhered viruses. (nanoe X Generator Mark 1 generates 4.8 trillion hydroxyl radicals/ sec)

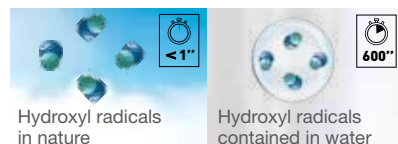

2 Longer lifespan

By creating hydroxyl radicals contained in water, nanoe™ X technology, increasing hydroxyl radicals lifetime so that nanoe™ X can spread over long distance.



3 Actively fill in the room

Going beyond standard filter technology, hydroxyl radicals circulate throughout rooms inhibiting both airborne and adhered bacteria and viruses.

Effective on Adhered Pollutants

Nano-sized (5-20 nm) nanoe™ X penetrates deep into fabrics and deodorises, inhibits bacteria, viruses, mould, allergens, pollen and hazardous substances. nanoe™ X extensively spread out through the room to inhibit adhered pollutants adhering to surfaces, while air filters only collect airborne dust but adhered substances.

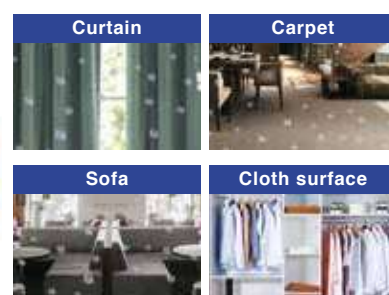
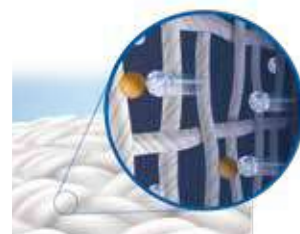

nanoe™ X actively purifies your air and inhibits pollutants all day long

Get quality air for you and your loved ones by turning nanoe™ X on in both cooling and heating modes. nanoe™ X device is maintenance-free, helping you keep your costs down with cleaner air.

Clean air independently when you are away (Fan Mode + nanoe™ X ON)



Comfort and Clean air when you are at home (Cooling or Heating Mode + nanoe™ X ON)



- nanoe™ X functions in cooling/heating as well as fan mode after business hours.
- Cleans indoor air even when the space is not in use.
- No need to consume excessive electricity to clean the air.



nanoe™ X cleans indoor air while maintaining a comfortable temperature when people are present.



After business hours, nanoe™ X keeps cleaning indoor air in fan mode.

*In case of using 2.2kW-7.3kW 4 way cassette models with fan tap L, flap position 5, standard panel. Energy consumption may vary depending on models.

Bringing nature's balance indoors

nanoe™ X technology with the benefits of hydroxyl radicals

The well-being benefits of nature are well known - but do you know the power of hydroxyl radicals?

Abundant in nature, hydroxyl radicals (also known as OH radicals) inhibit pollutants, viruses and bacteria to clean and deodorise. nanoe™ X technology brings these incredible benefits indoors by containing hydroxyl radicals in water, so that hard surfaces, soft furnishings and the indoor environment can be a clean and pleasant place to be, whether at home, at work, or visiting hotels, shops, restaurants etc.

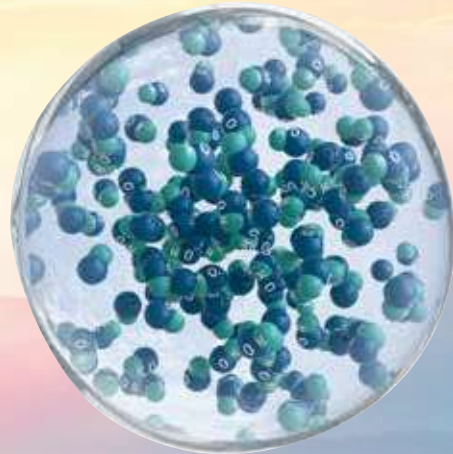

Hydroxyl radicals contained in water

A naturally occurring process

Hydroxyl radicals are unstable molecules looking to react with other elements like hydrogen molecules of pollutants, capturing it. Thanks to this reaction, hydroxyl radicals inhibit the growth of pollutants such as viruses, bacteria, moulds, and odours, breaking them down and neutralising the unpleasant effects. This naturally occurring process has major benefits to improve indoor environments.

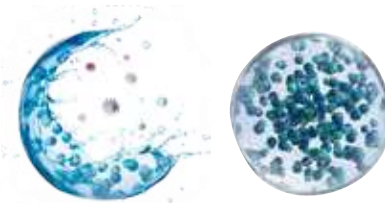

Bringing nature's balance indoors nanoe™ X technology with the benefits of hydroxyl radicals

nanoe™ X technology with the benefits of hydroxyl radicals

Panasonic's nanoe™ X technology takes a step further and brings nature's detergent - hydroxyl radicals - indoors to help create an ideal environment.

By creating hydroxyl radicals contained in water, nanoe™ X technology significantly boosts their effectiveness, increasing hydroxyl radicals lifetime from less than a second in nature, to more than 600 seconds – 10 minutes.



Hydroxyl radicals in nature



Hydroxyl radicals contained in water - nanoe™ X

<https://www.panasonic.com/global/consumer/clean/hydroxyl/technology.html>

Effectiveness of nanoe™ X

nanoe™ X deodorises, inhibits bacteria & viruses, mould, allergens, pollen and hazardous substances, as well as moisturising the whole room for smoother skin and hair.

Deodorises



Odours

Inhibits 5 types of pollutants



Bacteria & viruses



Mould



Allergens



Pollen



Hazardous substances

Moisturises



Skin & Hair

For further details and validation data, please refer to the following website:
https://aircon.panasonic.com/introducing/whats_nanoe/nanoe.html



Thanks to the nanoe™ X properties, several types of pollutants can be inhibited.



nanoe™ X reliably reaches pollutants.

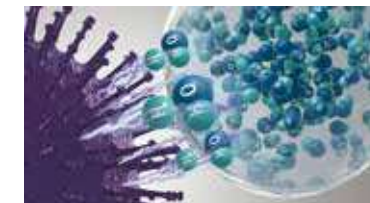

Hydroxyl radicals transform pollutants' proteins.



Pollutants activity is inhibited.

The evolution of nanoe™ X technology

After annual R&D investments, the technology has been improved with launch of nanoe™ X.

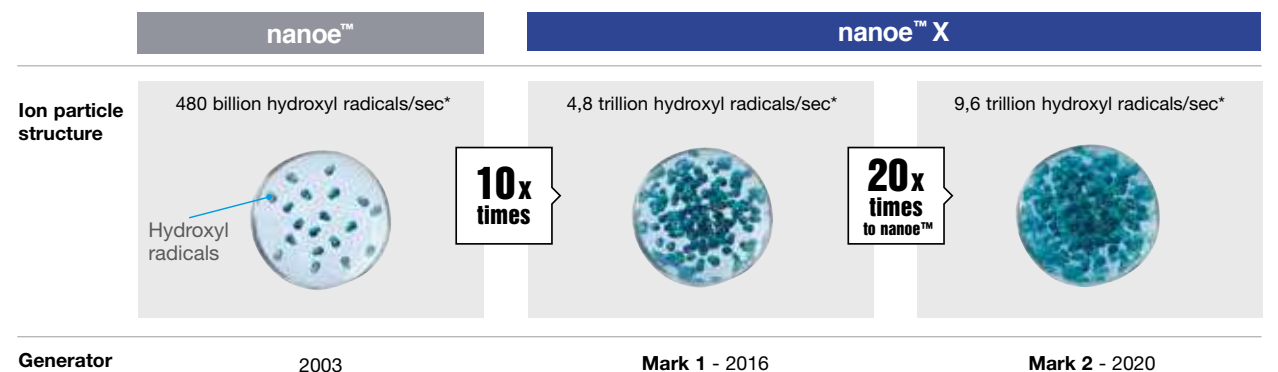

* Measured using ESR method

Verification tests for nanoe™ X effects in large spaces



Hazardous substances

The nanoe™ X inhibited hexadecane, a chemical contained in PM2.5 (267m²)

3rd party

A third-party certification organization SIRIM Berhad (SIRIM)^{*1}, conducted the performance experiment using a 4-Way Cassette equipped with a nanoe™ X device to inhibit hexadecane^{*2}, a chemical contained in PM2.5.

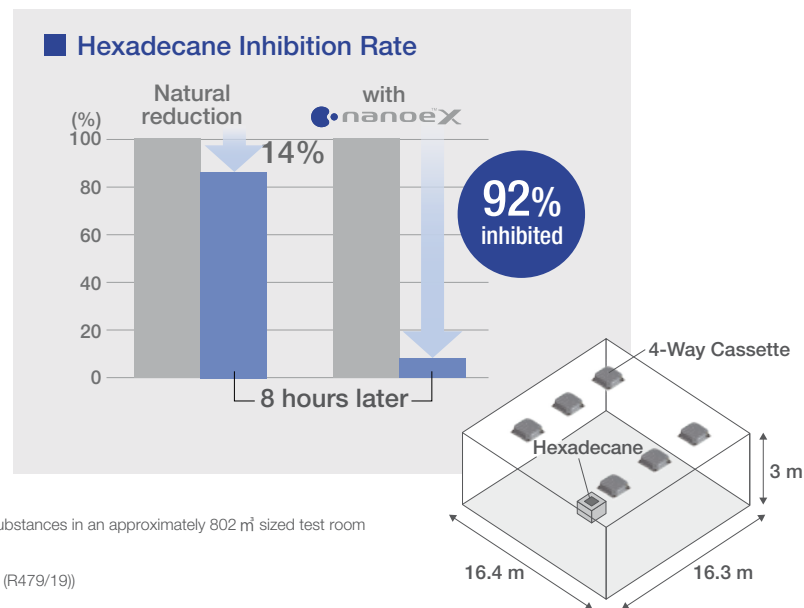

*1 SIRIM is a premier industrial research and technology organisation in Malaysia, a wholly-owned company of the Malaysian Government under the Ministry of International Trade and Industry (MITI).

*2 Hexadecane is a hazardous substance contained in gasoline and diesel exhaust gas.

Testing method: Measured the amount of attached organic substances in an approximately 802 m² sized test room
 Inhibition method: nanoe X Generator Mark 1 released
 Test substance: Hexadecane
 Test result: Broken down 92% in 8 hours (ETRC257/16/1402 (R479/19))



odours

The nanoe™ X reduced the odours adhering to fibers such as curtains and carpets (139m²)

3rd party

Cigarette smoke odour

Results

Compared to natural reduction, the nanoe™ X blast reduced the odour intensity by more than approximately 0.7 after two hours.

Testing organization

KAKEN TEST CENTER General Incorporated Foundation in Japan, international testing institute.

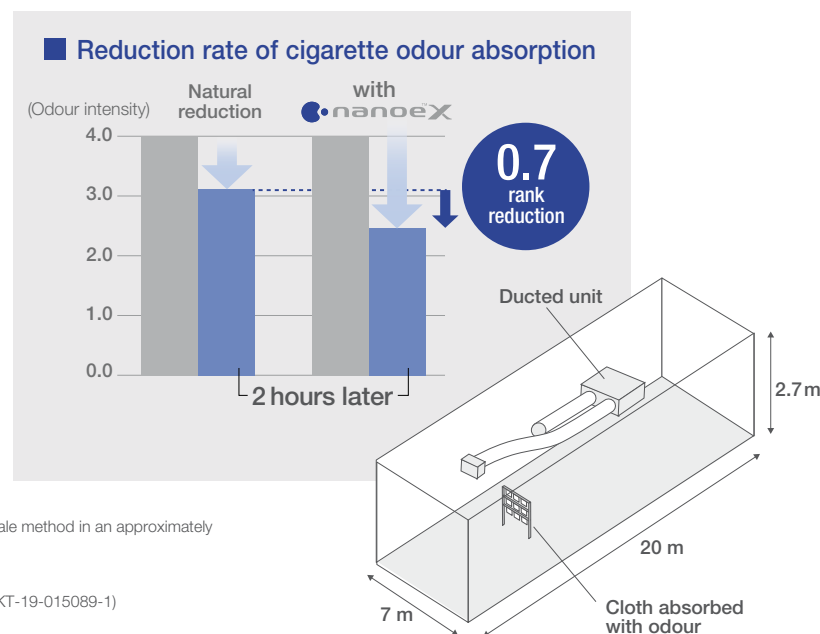

Testing method: Verified using the six-level odour intensity scale method in an approximately 378m² sized test room
 Inhibition method: nanoe X Generator Mark 2 released
 Test substance: Surface-attached cigarette smoke odour
 Test result: Odour intensity reduced by 0.7 levels in 2 hours (KT-19-015089-1)

The effects of nanoe™ X are recognised by experts in each field



Professor Masafumi Mukamoto

Osaka Prefecture University
 Veterinary Infectious Disease Studies

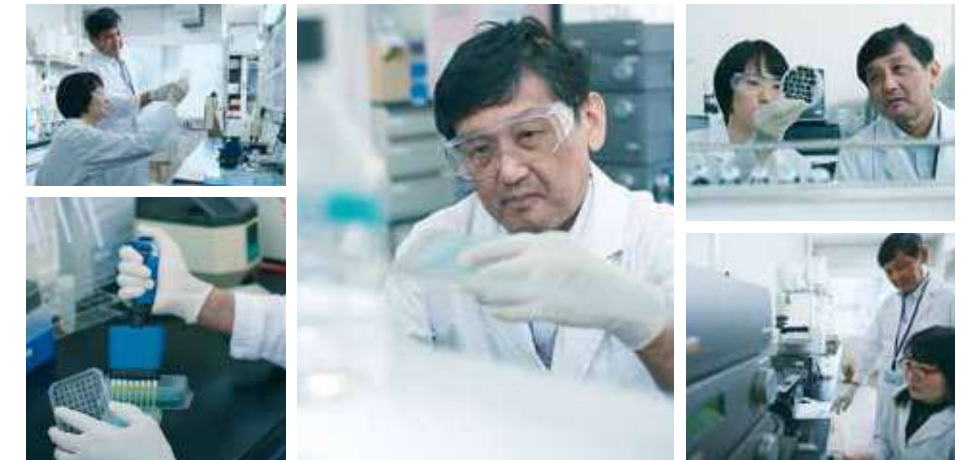

Various types of moulds enter houses along with people and air. Even if preventive action is taken in our everyday lives, it is often very difficult to inhibit the growth of mould, especially in humid environments. With nanoe™ X, we have experimental results^{*3*} that show we can inhibit the growth of the types of mould and bacteria commonly found in various places in the house.

Hope for the creation of more comfortable spaces for those who have problems with asthma or atopic dermatitis



Professor Masahiro Sakaguchi

Azabu University
 School of Veterinary Medicine
 Laboratory of Veterinary Microbiology I



We have experimental results that show nanoe™ X is capable of inhibiting allergens, such as pollen and dust mites. It is important to take precautions against the allergens that we inadvertently inhale in our daily lives. As nanoe™ X is effective in inhibiting invisible allergens, we can expect it will create a cleaner environment. As the safety of nanoe™ X has also been verified, nanoe™ X gives peace of mind to families with small children.

*3 Experimental results show that nanoe™ X is effective in inhibiting the growth of the following types of mould and bacteria commonly found in homes:
 Mould: Trichophyton, Cladosporium, Malassezia furfur, Sporothrix schenckii, Exophiala jeanselmei, Absidia corymbifera, Rhodotorula rubra, Neurospora sitophila, Schizophyllum commune
 Bacteria: Methicillin-resistant Staphylococcus aureus (MRSA), Listeria monocytogenes, Bacillus subtilis, Mycobacterium smegmatis, Nocardia asteroides, Neisseria gonorrhoeae, Salmonella enterica subsp. Enterica, Haemophilus influenzae, Campylobacter jejuni.
 *4 This verification was designed to generate basic research data on the effects of nanoe™ X on the mould and bacteria in laboratory conditions different from those found in living spaces. It was not designed to evaluate product performance.

Indoor Units

Wide choice of models depending on the indoor requirements

Key Indoor Units Equipped DC motors



Simplified Wired Remote Controller



CZ-RTC6

Simple and Sophisticated Design In-and-Out

User friendly interface with stylish design measuring just 86 x 86 mm, this is an extremely compact remote controller which looks great in any room.



All Ducted Series / F3, F2, M1, Z1, E2, E1, H1, type

Discharge air temperature control

Smart sensors control discharge air temperature for precise room temperature control. Possible to reduce cold drafts during heating operation.

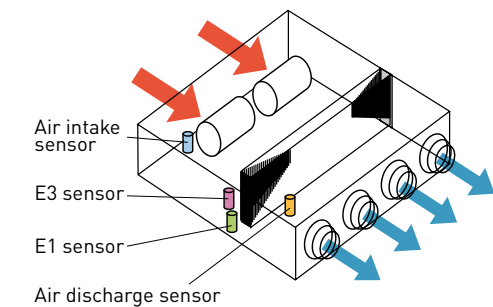

Wall Mounted / K2 (22~36), K2 (45~106) type



Compact design with flat surface enables seamless match with any type of room interior

Noise reducing external valve kit

To reduce noise level of expansion valve. (Optional accessory)



CZ-P56SVK2 (for 22 - 56 type)
CZ-P160SVK2 (for 73* - 106 type)

*When the pipe diameter is (Liquid) Ø6.35 - (Gas) Ø12.7, please use CZ-P56SVK2.

High-spec Wired Remote Controller



CZ-RTC5B

Large 3.5" full-dot LCD with white LED backlight

Characters and icons are clearly displayed for improved visibility. The display is also large enough to provide a wide range of information for easy confirmation of operation conditions.



Stylish, easy-to-use touch key design

The elegant, flat design features large touch keys in a simple layout enabling easy, intuitive operation.



Remote Temperature Sensor



CZ-CSRC3

- This is a remote sensor which can be used with indoor units. Use it to detect the room temperature when no remote controller sensor or body sensor is used (connection to a system without a remote controller is possible).
- For joint use with a remote control switch, use the remote control switch as main remote controller.

FSV Indoor Units Range

Wide choice of models depending on the indoor requirements

| Class | | 22 | 28 | 36 | 45 | 56 | 60 | 73 |
|---|-----------------|-----------------|-----------------|-----------------|-----------------|-----------------|-----------------|-----------------|
| Capacity | Cooling/Heating | Cooling/Heating | Cooling/Heating | Cooling/Heating | Cooling/Heating | Cooling/Heating | Cooling/Heating | Cooling/Heating |
| Type | kW | 2.2/2.5 | 2.8/3.2 | 3.6/4.2 | 4.5/5.0 | 5.6/6.3 | 6.0/7.1 | 7.3/8.0 |
| | BTU/h | 7,500/8,500 | 9,600/11,000 | 12,000/14,000 | 15,000/17,000 | 19,000/21,000 | 20,400/24,200 | 25,000/27,000 |
| nanoeX nanoe™ X as a standard F3 type Mid Static Adaptive Ducted | NEW | NEW | NEW | NEW | NEW | NEW | NEW | |
| | | | | | | | | |
| F2 type Mid Static Ducted | | | | | | | | |
| | | | | | | | | |
| M1 type Slim Low Static Ducted | | | | | | | | |
| | | | | | | | | |
| Z1 type Slim Low Static Ducted Twenty Series | | | | | | | | |
| | | | | | | | | |
| E2 type High Static Ducted / Energy Saving High-Fresh Air Ducted | | | | | | | | |
| | | | | | | | | |
| E1 type High Static Ducted | | | | | | | | |
| | | | | | | | | |
| H1 type High Fresh Air Ducted | | | | | | | | |
| | | | | | | | | |
| K2 type Wall Mounted | | | | | | | | |
| | NEW | NEW | NEW | NEW | NEW | NEW | NEW | |
| nanoeX nanoe™ X as a standard U2 type 4-Way Cassette Panel No. CZ-KPU3H Panel No. CZ-KPU3A | | | | | | | | |
| | | | | | | | | |
| Y2 type 4-Way Mini Cassette Panel No. CZ-KPY3AW | | | | | | | | |
| | | | | | | | | |
| L1 type 2-Way Cassette Panel No. CZ-02KPL2 Panel No. CZ-03KPL2 (Only for S-73ML1E5) | | | | | | | | |
| | | | | | | | | |
| D1 type 1-Way Cassette Panel No. CZ-KPD2 | | | | | | | | |
| | | | | | | | | |
| T2 type Ceiling | | | | | | | | |
| | | | | | | | | |
| P1 type Floor Standing | | | | | | | | |
| | | | | | | | | |

- Self-diagnosing function
- Automatic fan operation
- DRY** Dry mode
- Intelligent auto flap control
- Automatic restart function for power failure
- Air swing
- Built-in drain pump
- DC motor

| Class | | 90 | 106 | 140 | 160 | 180 | 224 | 280 | Wireless remote control | Functions | |
|------------|-----------------|-----------------|-----------------------|-----------------|-----------------|-----------------|-----------------------|-----------------------|---------------------------|---------------------------------------|--|
| Capacity | Cooling/Heating | Cooling/Heating | Cooling/Heating | Cooling/Heating | Cooling/Heating | Cooling/Heating | Cooling/Heating | Cooling/Heating | Type with built-in sensor | Type with separately installed sensor | |
| Type | kW | 9.0/10.0 | 10.6/11.4 | 14.0/16.0 | 16.0/18.0 | 18.0/20.0 | 22.4/25.0 | 28.0/31.5 | | | |
| | BTU/h | 30,000/34,000 | 36,000/39,000 | 47,800/54,600 | 54,600/61,500 | 61,400/68,200 | 76,400/85,300 | 95,500/107,500 | | | |
| NEW | | | | | | | | | | | |
| | | | | | | | | | | | |
| | | | | | | | | | | | |
| | | | | | | | | | | | |
| | | | | | | | High Fresh Air | High Fresh Air | | | |
| | | | | | | | | | | | |
| | | | High Fresh Air | | | | High Fresh Air | High Fresh Air | | | |
| | | | | | | | | | | | |
| NEW | NEW | NEW | NEW | | | | | | | | |
| | | | | | | | | | | | |
| | | | | | | | | | | | |
| | | | | | | | | | | | |
| | | | | | | | | | | | |
| | | | | | | | | | | | |

NEW

F3 TYPE Mid Static Adaptive Ducted

Control all aspects of your environment with exceptional performance and quiet operation. Vertical installation flexibility offers the perfect solution when ceiling heights are restricted.



S-22MF3E5A / S-28MF3E5A / S-36MF3E5A / S-45MF3E5A / S-56MF3E5A



S-60MF3E5A / S-73MF3E5A / S-90MF3E5A



S-106MF3E5A / S-140MF3E5A / S-160MF3E5A

nanoe™ X as a standard*
*nanoe X Generator Mark 2

- DC motor
- Self-diagnosing Function
- Automatic Fan Operation
- DRY (Dry mode)
- Automatic Restart Function
- Built-in Drain Pump

Optional accessory

ECONAVI
ECONAVI ready

CZ-RTC6 CZ-CENSC1 CZ-RTC5B CZ-RWS3 Remote controller CZ-RWRC3 Receiver

Technical focus

- 4 installation possibilities with horizontal and vertical mounting and selectable rear or bottom air inlet
- Space saving 250mm height
- DC fan motor for variable external static pressure control
- Industry-leading horizontal/vertical design
- Powerful 150Pa static pressure in a compact unit.
- Leading-class low sound levels from 20 dB(A)
- Improved drain pan suitable for both horizontal / vertical installation
- nanoe™ X : 20x for CAC (20 times more nanoe™ particle for wide commercial space)
- Accurate temperature control to reduce cold drafts during operation
- Configurable air temperature control

Variable external static pressure control

Optimal airflow set-up is possible depending on ducting design and conditions.

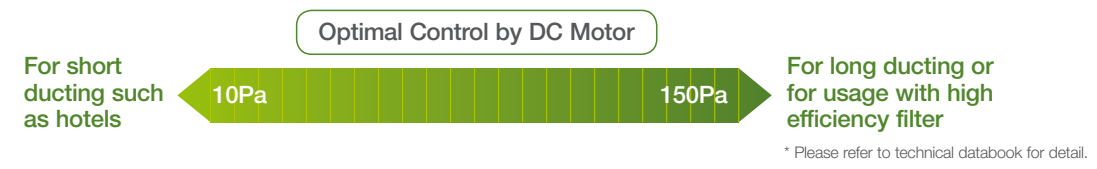

Powerful 150Pa external static pressure in an industry-leading horizontal/vertical installation design

Delivering static pressure up to 150Pa external static pressure, the industry-leading horizontal/vertical design offers the power you need in a compact form factor.

250mm

Improved drain pan design

Drain pan is shared in both cases horizontal and vertical installation. No need to alternate anymore.

Horizontal

Vertical

Shared drain pan

Superior Air Quality

Combined with the strong static pressure this model ensures pristine nanoe™ X air travels unaffected even through multiple duct shapes at lengths of 10m, as well as making them ideal for use in larger spaces.

10m

Bend once Bend twice Bend three times



As the experiments demonstrate, even with a total ductwork length of up to 10m, effectiveness of nanoe™ X is maintained.

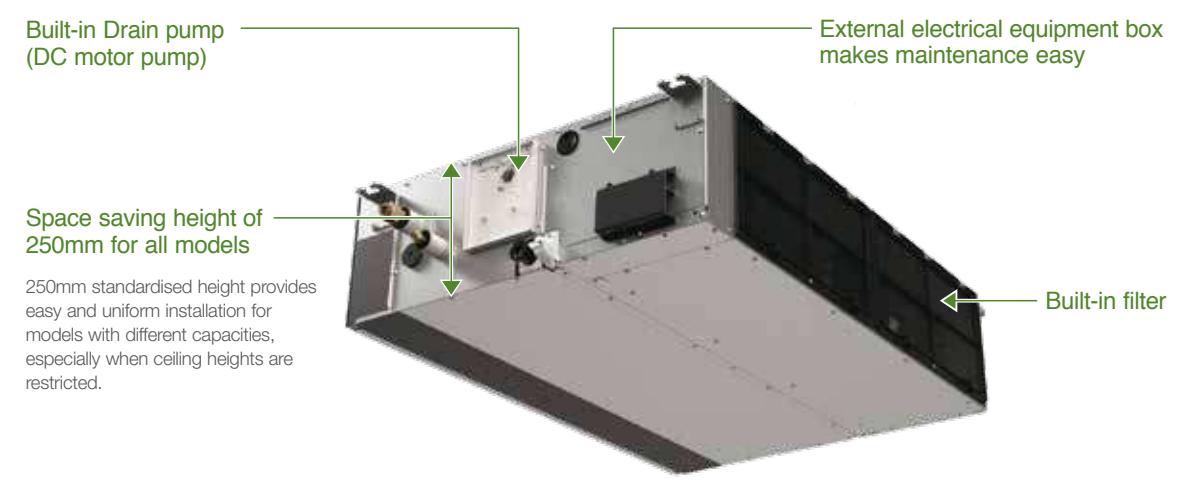

Discharge air temperature control

- Possible to control discharge air temperature for accurate room temperature control.
- Possible to reduce cold drafts during heating operation.

Note: Before spec-in, please consult with an authorised Panasonic dealer.

Air intake sensor

E3 sensor

E1 sensor

Air discharge sensor

Selectable air inlet position

A removable panel allows air inlet position to be adjusted to enable rear or bottom entry, depending on ductwork installation.

System example

An inspection port (450 mm x 450 mm or larger) is required at the lower side of the indoor unit body.

Rectangle duct

Canvas duct

Inspection port (450 x 450 mm or more)

Intake grille

More powerful drain pump

Using a high-lift built-in drain pump, drain piping can be elevated up to 701 mm from the base of the unit.

Up to 300 mm

Up to 500 mm

201 mm

F3 TYPE Mid Static Adaptive Ducted

| Model Name | S-22MF3E5A | S-28MF3E5A | S-36MF3E5A | S-45MF3E5A | S-56MF3E5A | | |
|------------------------------|-----------------------------------|----------------|-----------------|-----------------|-----------------|-------------------|-----------------|
| Power source | 220/230/240 V, 1 phase - 50/60 Hz | | | | | | |
| Cooling capacity | kW | 2.2 | 2.8 | 3.6 | 4.5 | 5.6 | |
| | BTU/h | 7,500 | 9,600 | 12,300 | 15,400 | 19,100 | |
| Heating capacity | kW | 2.5 | 3.2 | 4.2 | 5.0 | 6.3 | |
| | BTU/h | 8,500 | 10,900 | 14,300 | 17,100 | 21,500 | |
| Power input | Cooling kW | 0.06/0.06/0.06 | 0.06/0.06/0.06 | 0.06/0.06/0.06 | 0.06/0.06/0.06 | 0.089/0.089/0.089 | |
| | Heating kW | 0.06/0.06/0.06 | 0.06/0.06/0.06 | 0.06/0.06/0.06 | 0.06/0.06/0.06 | 0.089/0.089/0.089 | |
| Running amperes | Cooling A | 0.46/0.45/0.44 | 0.46/0.45/0.44 | 0.46/0.45/0.44 | 0.46/0.45/0.44 | 0.65/0.63/0.61 | |
| | Heating A | 0.46/0.45/0.44 | 0.46/0.45/0.44 | 0.46/0.45/0.44 | 0.46/0.45/0.44 | 0.65/0.63/0.61 | |
| Fan motor | Type | Sirocco fan | Sirocco fan | Sirocco fan | Sirocco fan | Sirocco fan | |
| | Air flow rate (H/M/L) | m³/h | 840/720/480 | 840/720/480 | 840/720/480 | 840/720/480 | 960/840/600 |
| | | L/s | 233/200/133 | 233/200/133 | 233/200/133 | 233/200/133 | 267/233/167 |
| | Output | kW | 0.107 | 0.107 | 0.107 | 0.107 | 0.107 |
| | External static pressure | Pa | 30 (10-150) | 30 (10-150) | 30 (10-150) | 30 (10-150) | 30 (10-150) |
| Sound power level (H/M/L) | dB | 54/51/43 | 54/51/43 | 54/51/43 | 54/51/43 | 58/55/47 | |
| Sound pressure sound (H/M/L) | dB(A) | 31/28/20 | 31/28/20 | 31/28/20 | 31/28/20 | 35/32/24 | |
| Dimensions | H x W x D | mm | 250 x 800 x 730 | 250 x 800 x 730 | 250 x 800 x 730 | 250 x 800 x 730 | 250 x 800 x 730 |
| | Liquid | mm (inches) | Ø6.35 (Ø1/4) | Ø6.35 (Ø1/4) | Ø6.35 (Ø1/4) | Ø6.35 (Ø1/4) | Ø6.35 (Ø1/4) |
| Pipe connections | Gas | mm (inches) | Ø12.7 (Ø1/2) | Ø12.7 (Ø1/2) | Ø12.7 (Ø1/2) | Ø12.7 (Ø1/2) | Ø12.7 (Ø1/2) |
| | Drain piping | | VP-20 | VP-20 | VP-20 | VP-20 | VP-20 |
| Net weight | kg | 26 | 26 | 26 | 26 | 26 | |

| S-60MF3E5A | S-73MF3E5A | S-90MF3E5A | S-106MF3E5A | S-140MF3E5A | S-160MF3E5A |
|-----------------------------------|-------------------|-------------------|-------------------|-------------------|-------------------|
| 220/230/240 V, 1 phase - 50/60 Hz | | | | | |
| 6.0 | 7.3 | 9.0 | 10.6 | 14.0 | 16.0 |
| 20,500 | 24,900 | 30,700 | 36,200 | 47,800 | 54,600 |
| 7.1 | 8.0 | 10.0 | 11.4 | 16.0 | 18.0 |
| 24,200 | 27,300 | 34,100 | 38,900 | 54,600 | 61,400 |
| 0.079/0.079/0.079 | 0.079/0.079/0.079 | 0.136/0.136/0.136 | 0.146/0.146/0.146 | 0.265/0.265/0.265 | 0.330/0.330/0.330 |
| 0.079/0.079/0.079 | 0.079/0.079/0.079 | 0.136/0.136/0.136 | 0.146/0.146/0.146 | 0.265/0.265/0.265 | 0.330/0.330/0.330 |
| 0.53/0.52/0.51 | 0.53/0.52/0.51 | 0.92/0.90/0.88 | 1.03/1.00/0.97 | 1.80/1.76/1.72 | 2.22/2.14/2.09 |
| 0.53/0.52/0.51 | 0.53/0.52/0.51 | 0.92/0.90/0.88 | 1.03/1.00/0.97 | 1.80/1.76/1.72 | 2.22/2.14/2.09 |
| Sirocco fan | Sirocco fan | Sirocco fan | Sirocco fan | Sirocco fan | Sirocco fan |
| 1,260/1,080/900 | 1,260/1,080/900 | 1,500/1,380/960 | 1,920/1,560/1,260 | 2,220/1,920/1,560 | 2,400/2,040/1,680 |
| 350/300/250 | 350/300/250 | 417/383/267 | 533/433/350 | 617/533/433 | 667/567/467 |
| 0.165 | 0.165 | 0.165 | 0.259 | 0.259 | 0.259 |
| 30 (10-150) | 30 (10-150) | 40 (10-150) | 40 (10-150) | 50 (10-150) | 50 (10-150) |
| 54/51/46 | 54/51/46 | 58/56/48 | 59/55/50 | 64/59/55 | 66/60/56 |
| 31/28/23 | 31/28/23 | 35/33/25 | 36/32/27 | 41/36/32 | 43/37/33 |
| 250 x 1,000 x 730 | 250 x 1,000 x 730 | 250 x 1,000 x 730 | 250 x 1,400 x 730 | 250 x 1,400 x 730 | 250 x 1,400 x 730 |
| Ø9.52 (Ø3/8) | Ø9.52 (Ø3/8) | Ø9.52 (Ø3/8) | Ø9.52 (Ø3/8) | Ø9.52 (Ø3/8) | Ø9.52 (Ø3/8) |
| Ø15.88 (Ø5/8) | Ø15.88 (Ø5/8) | Ø15.88 (Ø5/8) | Ø15.88 (Ø5/8) | Ø15.88 (Ø5/8) | Ø15.88 (Ø5/8) |
| VP-20 | VP-20 | VP-20 | VP-20 | VP-20 | VP-20 |
| 31 | 31 | 31 | 40 | 40 | 40 |

| | | | |
|----------------|-------------------------|-------------------|-----------------|
| GLOBAL REMARKS | Rated conditions: | Cooling | Heating |
| | Indoor air temperature | 27°C DB / 19°C WB | 20°C DB |
| | Outdoor air temperature | 35°C DB / 24°C WB | 7°C DB / 6°C WB |

Specifications are subject to change without notice.

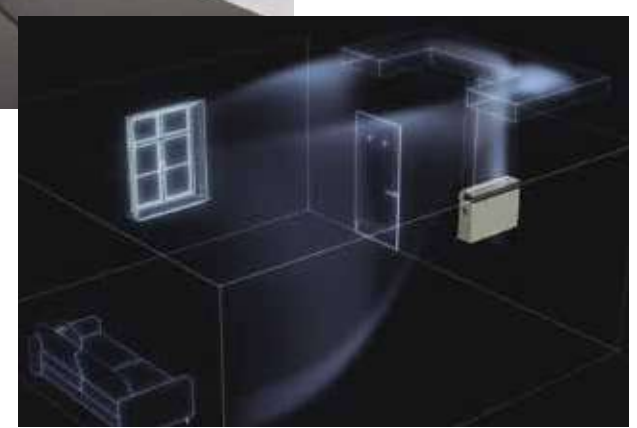

F3 TYPE MID STATIC DUCTED Dimensions

| Type | A | B | C | D | E | F |
|----------------|-------|-------|-----------------------|----|-------|------|
| | mm | mm | mm | mm | mm | Q'ty |
| 22/28/36/45/56 | 867 | 800 | 450 (Pitch 150 × 3) | 71 | 592 | 12 |
| 60/73/90 | 1,067 | 1,000 | 750 (Pitch 150 × 5) | 21 | 792 | 16 |
| 106/140/160 | 1,467 | 1,400 | 1,050 (Pitch 150 × 7) | 71 | 1,192 | 20 |

- ① Refrigerant tubing joint (liquid tube)
S-22/28/36/45/56MF3E5A : Φ6.35 (flared)
S-60/73/90/106/140/160MF3E5A : Φ9.52 (flared)
- ② Refrigerant tubing joint (gas tube)
S-22/28/36/45/56MF3E5A : Φ12.7 (flared)
S-60/73/90/106/140/160MF3E5A : Φ15.88 (flared)
- ③ Upper drain port VP20 (ø26 mm)
200 mm flexible hose supplied
- ④ Bottom drain port VP20 (ø26 mm)
- ⑤ Suspension lug (4 – 12 × 30 mm)
- ⑥ Power supply outlet
- ⑦ Fresh air intake port (ø100 mm)^{*1}
- ⑧ Flange for flexible air outlet duct
- ⑨ Electrical component box

*1 Necessary to attach duct connecting flange (field supply).

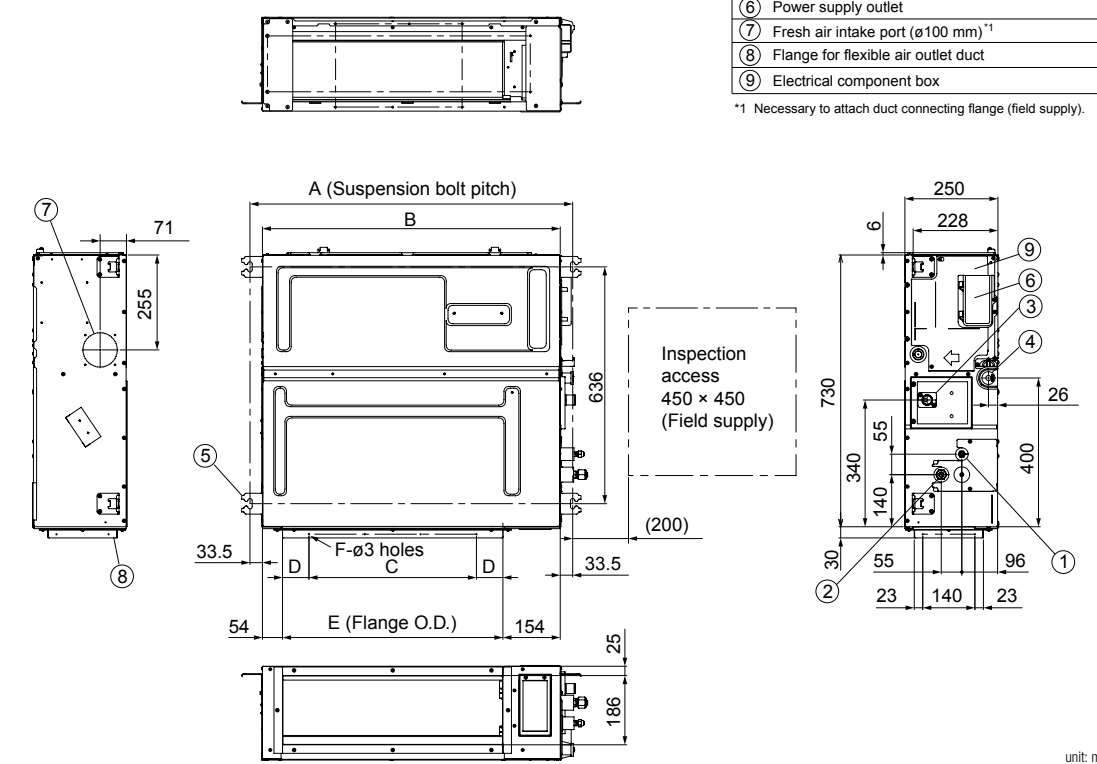

unit: mm

F2 TYPE Mid Static Ducted

F2 type is designed specifically for applications requiring fixed square ducting.



Optional accessory



Technical focus

- Variable external static pressure control
- Industry-leading low sound levels from 25 dB(A)
- Built-in drain pump provides 702 mm lift
- Easy to install and maintain
- Air off sensor avoids cold air drafts during heating operation
- Configurable air temperature control

Variable external static pressure control

Optimal airflow set-up is possible depending on ducting design and conditions.

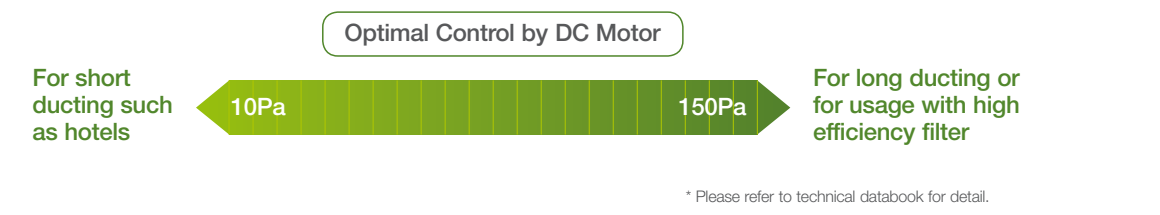

System example

An inspection port (450 mm x 450 mm or larger) is required at the lower side of the indoor unit body.

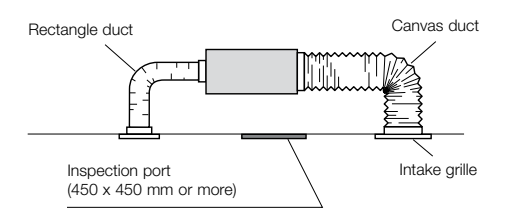

More powerful drain pump

Using a high-lift drain pump, drain piping can be elevated up to 702 mm from the base of the unit.

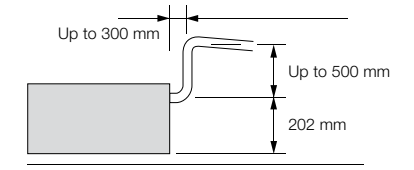

Built-in Drain pump (DC motor pump)

Standardised height of 290 mm for all models

Height standardisation enables easy and uniform installation for models with different capacities.

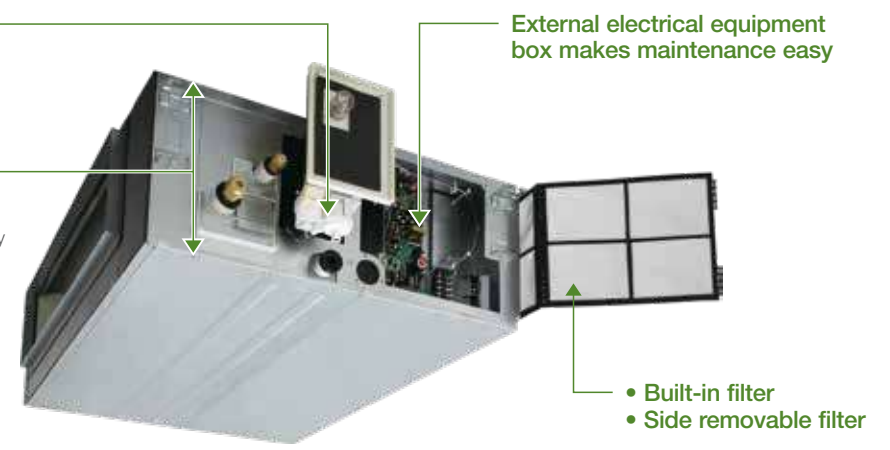

Discharge air temperature control

- Possible to control discharge air temperature for accurate room temperature control.
- Possible to reduce cold drafts during heating operation.

Note: Before spec-in, please consult with an authorised Panasonic dealer.

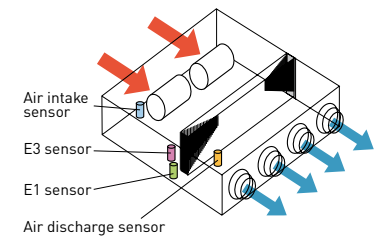

V-shaped heat exchanger

To improve heat exchange efficiency, an original V-shaped heat exchanger was developed incorporating a conventional high-efficiency slit fan and high-efficiency grooved heat transfer tubes. This increases the heat exchange surface area by about 80%.

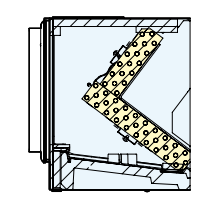

Increases surface area by about 30 to 80%



F2_{TYPE} Mid Static Ducted

| Model Name | S-22MF2E5A | S-28MF2E5A | S-36MF2E5A | S-45MF2E5A | S-56MF2E5A | | |
|------------------------------|-----------------------------------|-------------------|-------------------|-------------------|-------------------|-------------------|-------------|
| Power source | 220/230/240 V, 1 phase - 50/60 Hz | | | | | | |
| Cooling capacity | kW | 2.2 | 2.8 | 3.6 | 4.5 | 5.6 | |
| | BTU/h | 7,500 | 9,600 | 12,300 | 15,400 | 19,100 | |
| Heating capacity | kW | 2.5 | 3.2 | 4.2 | 5.0 | 6.3 | |
| | BTU/h | 8,500 | 10,900 | 14,300 | 17,100 | 21,500 | |
| Power input | Cooling kW | 0.070/0.070/0.070 | 0.070/0.070/0.070 | 0.070/0.070/0.070 | 0.070/0.070/0.070 | 0.100/0.100/0.100 | |
| | Heating kW | 0.070/0.070/0.070 | 0.070/0.070/0.070 | 0.070/0.070/0.070 | 0.070/0.070/0.070 | 0.100/0.100/0.100 | |
| Running amperes | Cooling A | 0.60/0.57/0.56 | 0.60/0.57/0.56 | 0.60/0.57/0.56 | 0.60/0.57/0.56 | 0.77/0.74/0.71 | |
| | Heating A | 0.60/0.57/0.56 | 0.60/0.57/0.56 | 0.60/0.57/0.56 | 0.60/0.57/0.56 | 0.77/0.74/0.71 | |
| Fan motor | Type | Sirocco fan | | | | | |
| | Air flow rate (H/M/L) | m ³ /h | 840/780/540 | 840/780/540 | 840/780/540 | 840/780/600 | 960/900/720 |
| | | L/s | 233/217/150 | 233/217/150 | 233/217/150 | 233/217/167 | 267/250/200 |
| | Output | kW | 0.119 | 0.119 | 0.119 | 0.119 | 0.119 |
| | External static pressure | Pa | 70(10-150) | 70(10-150) | 70(10-150) | 70(10-150) | 70(10-150) |
| Sound power level (H/M/L) | dB | 55/51/44 | 55/51/44 | 55/51/44 | 56/54/47 | 56/54/47 | |
| Sound pressure sound (H/M/L) | dB(A) | 33/29/22 | 33/29/22 | 33/29/22 | 34/32/25 | 34/32/25 | |
| Dimensions | H x W x D | mm | | | | | |
| | | 290x800x700 | | | | | |
| Pipe connections | Liquid | mm (inches) | Ø6.35 (Ø1/4) | Ø6.35 (Ø1/4) | Ø6.35 (Ø1/4) | Ø6.35 (Ø1/4) | |
| | Gas | mm (inches) | Ø12.7 (Ø1/2) | Ø12.7 (Ø1/2) | Ø12.7 (Ø1/2) | Ø12.7 (Ø1/2) | |
| | Drain piping | | VP-25 | VP-25 | VP-25 | VP-25 | |
| Net weight | kg | 29 | 29 | 29 | 29 | 29 | |

| GLOBAL REMARKS | Rated conditions: | |
|-------------------------|------------------------|-------------------|
| | Cooling | Heating |
| | Indoor air temperature | 27°C DB / 19°C WB |
| Outdoor air temperature | 35°C DB / 24°C WB | 7°C DB / 6°C WB |

Specifications are subject to change without notice.

| S-60MF2E5A | S-73MF2E5A | S-90MF2E5A | S-106MF2E5A | S-140MF2E5A | S-160MF2E5A |
|----------------------------------|-------------------|-------------------|-------------------|-------------------|-------------------|
| 220/230/240V, 1 phase - 50/60 Hz | | | | | |
| 6.0 | 7.3 | 9.0 | 10.6 | 14.0 | 16.0 |
| 20,500 | 24,900 | 30,700 | 36,200 | 47,800 | 54,600 |
| 7.1 | 8.0 | 10.0 | 11.4 | 16.0 | 18.0 |
| 24,200 | 27,300 | 34,100 | 38,900 | 54,600 | 61,400 |
| 0.120/0.120/0.120 | 0.120/0.120/0.120 | 0.135/0.135/0.135 | 0.195/0.195/0.195 | 0.215/0.215/0.215 | 0.225/0.225/0.225 |
| 0.120/0.120/0.120 | 0.120/0.120/0.120 | 0.135/0.135/0.135 | 0.200/0.200/0.200 | 0.210/0.210/0.210 | 0.225/0.225/0.225 |
| 0.91/0.89/0.87 | 0.91/0.89/0.87 | 0.99/0.97/0.95 | 1.35/1.30/1.27 | 1.48/1.44/1.39 | 1.55/1.50/1.47 |
| 0.91/0.89/0.87 | 0.91/0.89/0.87 | 0.99/0.97/0.95 | 1.37/1.34/1.29 | 1.46/1.42/1.38 | 1.55/1.50/1.46 |
| Sirocco fan | Sirocco fan | Sirocco fan | Sirocco fan | Sirocco fan | Sirocco fan |
| 1,260/1,140/900 | 1,260/1,140/900 | 1,500/1,380/1,140 | 1,920/1,560/1,260 | 2,040/1,740/1,380 | 2,160/1,860/1,500 |
| 350/317/250 | 350/317/250 | 417/383/317 | 533/433/350 | 567/483/383 | 600/533/417 |
| 0.124 | 0.124 | 0.124 | 0.235 | 0.235 | 0.235 |
| 70(10-150) | 70(10-150) | 70(10-150) | 100(10-150) | 100(10-150) | 100(10-150) |
| 57/54/48 | 57/54/48 | 59/56/50 | 60/56/53 | 61/57/54 | 62/58/55 |
| 35/32/26 | 35/32/26 | 37/34/28 | 38/34/31 | 39/35/32 | 40/36/33 |
| 290x1,000x700 | 290x1,000x700 | 290x1,000x700 | 290x1,400x700 | 290x1,400x700 | 290x1,400x700 |
| Ø9.52 (Ø3/8) | Ø9.52 (Ø3/8) | Ø9.52 (Ø3/8) | Ø9.52 (Ø3/8) | Ø9.52 (Ø3/8) | Ø9.52 (Ø3/8) |
| Ø15.88 (Ø5/8) | Ø15.88 (Ø5/8) | Ø15.88 (Ø5/8) | Ø15.88 (Ø5/8) | Ø15.88 (Ø5/8) | Ø15.88 (Ø5/8) |
| VP-25 | VP-25 | VP-25 | VP-25 | VP-25 | VP-25 |
| 34 | 34 | 34 | 46 | 46 | 46 |

F2 TYPE MID STATIC DUCTED Dimensions

SIZE 22-56

- 1 Refrigerant piping joint (liquid tube) Ø6.35 Flare
- 2 Refrigerant piping joint (gas tube) Ø12.7 Flare
- 3 Upper drain port VP25 (O.D. Ø32 mm)
- 4 Bottom drain port VP25 (O.D. Ø32 mm)
- 5 Suspension lug (4-12 x 30 mm)
- 6 Power supply outlet
- 7 Fresh air intake port (Ø150 mm)
- 8 Flange for flexible air outlet duct
- 9 Electrical component box

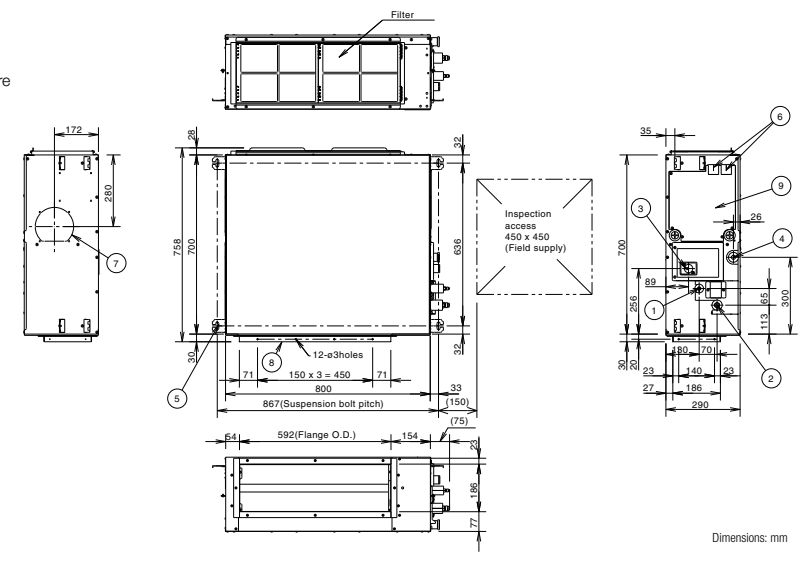

Dimensions: mm

SIZE 60-90

- 1 Refrigerant piping joint (liquid tube) Ø9.52 Flare
- 2 Refrigerant piping joint (gas tube) Ø15.88 Flare
- 3 Upper drain port VP25 (O.D. Ø32 mm)
- 4 Bottom drain port VP25 (O.D. Ø32 mm)
- 5 Suspension lug (4-12 x 30 mm)
- 6 Power supply outlet
- 7 Fresh air intake port (Ø150 mm)
- 8 Flange for flexible air outlet duct
- 9 Electrical component box

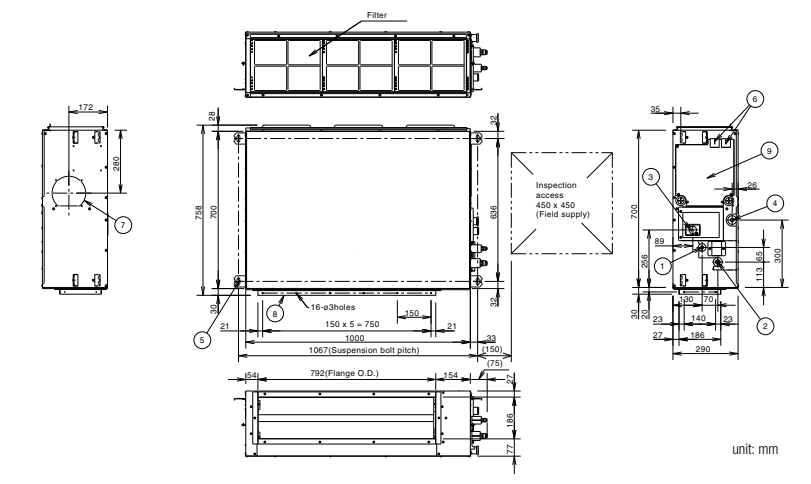

unit: mm

SIZE 106-160

- 1 Refrigerant piping joint (liquid tube) Ø9.52 Flare
- 2 Refrigerant piping joint (gas tube) Ø15.88 Flare
- 3 Upper drain port VP25 (O.D. Ø32 mm)
- 4 Bottom drain port VP25 (O.D. Ø32 mm)
- 5 Suspension lug (4-12 x 30 mm)
- 6 Power supply outlet
- 7 Fresh air intake port (Ø150 mm)
- 8 Flange for flexible air outlet duct
- 9 Electrical component box

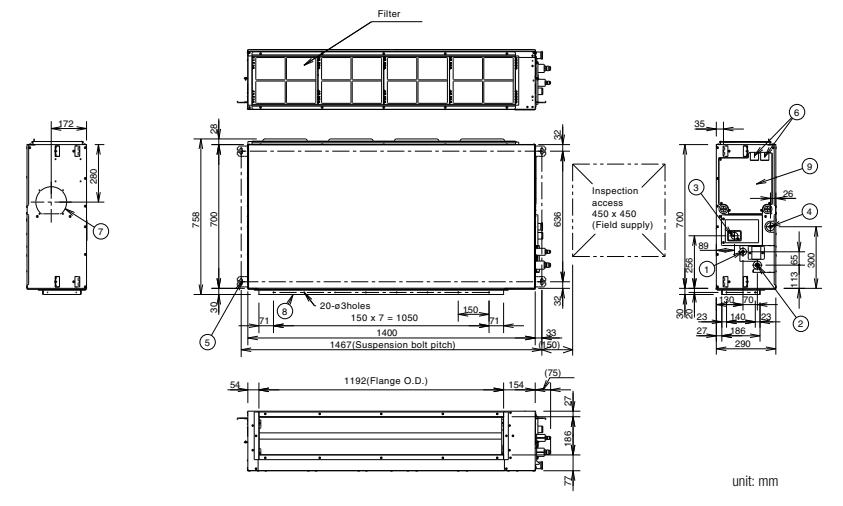

unit: mm

M1_{TYPE} Slim Low Static Ducted Concealed duct



The ultra slim M1 type is one of the leading products of its type in the industry. With a height of only 200 mm, it provides greater flexibility and adaptability for various applications. In addition, high efficiency and extreme low noise level make it highly suitable for hotels and small offices.



S-22MM1E5A / S-28MM1E5A / S-36MM1E5A
S-45MM1E5A / S-56MM1E5A

Optional accessory



Technical focus

- Ultra-slim profile: 200 mm for all models
- DC fan motor greatly reduces power consumption
- Ideal for hotel application with very narrow false ceilings
- Easy maintenance and service by external electrical box
- 40 Pa static pressure enables ductwork to be fitted.
- Includes drain pump

Ultra-slim profile for all models

200mm height for all models allows installation in very narrow ceilings.



Drain pump with increased power!

Using the built-in high-lift drain pump, the drain piping rise height can be increased to 653 mm from the lower surface of the body.

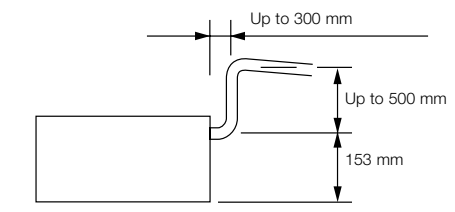

| Model Name | | S-22MM1E5A | S-28MM1E5A | S-36MM1E5A | S-45MM1E5A | S-56MM1E5A |
|------------------------------------|-----------------------------|-----------------------------------|----------------------|----------------------|----------------------|----------------------|
| Power source | | 220/230/240 V, 1 phase - 50/60 Hz | | | | |
| Cooling capacity | kW | 2.2 | 2.8 | 3.6 | 4.5 | 5.6 |
| | BTU/h | 7,500 | 9,600 | 12,300 | 15,400 | 19,100 |
| Heating capacity | kW | 2.5 | 3.2 | 4.2 | 5.0 | 6.3 |
| | BTU/h | 8,500 | 10,900 | 14,300 | 17,100 | 21,500 |
| Power input | Cooling kW | 0.036/0.036/0.036 | 0.040/0.040/0.040 | 0.042/0.042/0.042 | 0.049/0.049/0.049 | 0.064/0.064/0.064 |
| | Heating kW | 0.026/0.026/0.026 | 0.030/0.030/0.030 | 0.032/0.032/0.032 | 0.039/0.039/0.039 | 0.054/0.054/0.054 |
| Running current | Cooling A | 0.26/0.26/0.26 | 0.30/0.30/0.30 | 0.31/0.31/0.31 | 0.37/0.37/0.37 | 0.48/0.48/0.48 |
| | Heating A | 0.23/0.23/0.23 | 0.27/0.27/0.27 | 0.28/0.28/0.28 | 0.34/0.34/0.34 | 0.45/0.45/0.45 |
| Fan | Type | Sirocco fan | | | | |
| | Air flow rate (H/M/L) m³/h | 480/420/360 | 510/450/390 | 540/480/420 | 630/570/480 | 750/690/600 |
| | L/s | 133/117/100 | 142/125/108 | 150/133/117 | 175/158/133 | 208/192/167 |
| | Motor output kW | 0.06 | 0.06 | 0.06 | 0.06 | 0.06 |
| | External static pressure Pa | 10 (30) | 15 (30) | 15 (40) | 15 (40) | 15 (40) |
| Sound power level (H/M/L) dB | | 43/42/40 | 45/44/42 | 47/45/43 | 49/47/45 | 52/50/48 |
| Sound pressure level (H/M/L) dB(A) | | 28/27/25 (30/29/27)* | 30/29/27 (32/31/29)* | 32/30/28 (34/32/30)* | 34/32/30 (36/34/32)* | 35/33/31 (37/35/32)* |
| Dimensions H x W x D mm | | 200 x 750 x 640 | | | | |
| | Liquid mm (inches) | Ø6.35 (Ø1/4) | Ø6.35 (Ø1/4) | Ø6.35 (Ø1/4) | Ø6.35 (Ø1/4) | Ø6.35 (Ø1/4) |
| Pipe connections | Gas mm (inches) | Ø12.7 (Ø1/2) | Ø12.7 (Ø1/2) | Ø12.7 (Ø1/2) | Ø12.7 (Ø1/2) | Ø12.7 (Ø1/2) |
| | Drain piping | VP-20 | | | | |
| Net weight kg | | 19 | 19 | 19 | 19 | 19 |

| GLOBAL REMARKS | Rated conditions: | Cooling | Heating |
|----------------|-------------------------|-------------------|-----------------|
| | Indoor air temperature | 27°C DB / 19°C WB | 20°C DB |
| | Outdoor air temperature | 35°C DB / 24°C WB | 7°C DB / 6°C WB |

Specifications are subject to change without notice. * With booster cable.

M1 TYPE SLIM LOW STATIC DUCTED Dimensions

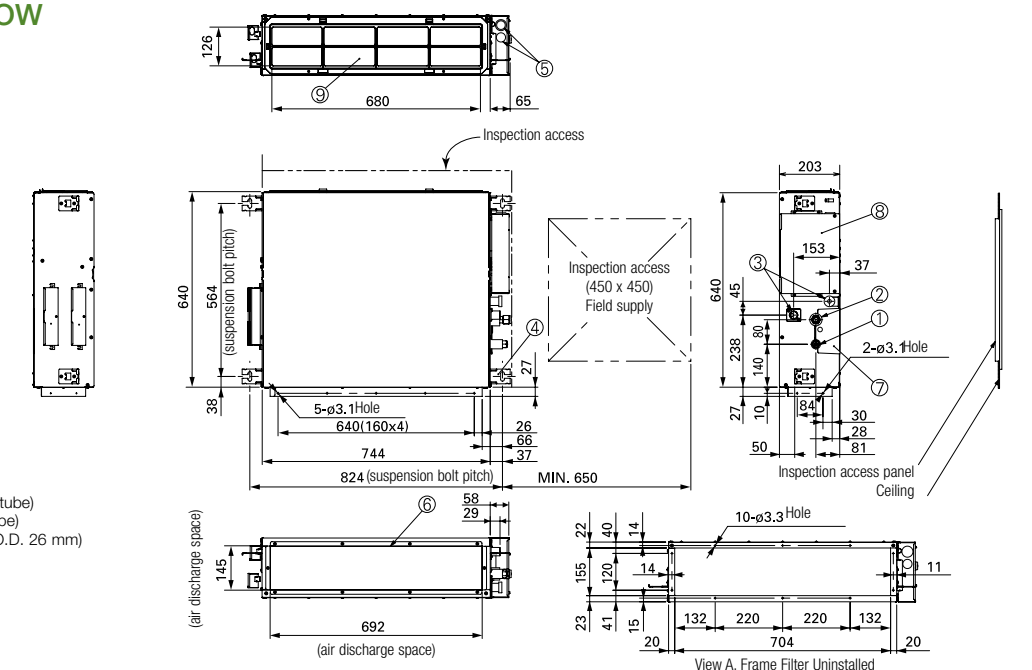

- 1 Refrigerant piping joint (narrow tube)
- 2 Refrigerant piping joint (wide tube)
- 3 Upper and bottom drain port (O.D. 26 mm)
- 4 Suspension lug
- 5 Power supply outlet (2- Ø30)
- 6 Flange for air intake duct
- 7 PI cover
- 8 Electrical component box
- 9 Frame filter

unit: mm

Z1 TYPE Slim Low Static Ducted Twenty Series Concealed duct

The ultra slim Z1 type is one of the leading products of its type in the industry. With a height of only 200 mm, it provides greater flexibility and adaptability for various applications. In addition, high efficiency and extreme low noise level make it highly suitable for hotels and small offices.



S-22MZ1H4A/ S-28MZ1H4A/ S-36MZ1H4A
S-45MZ1H4A/ S-56MZ1H4A/ S-60MZ1H4A

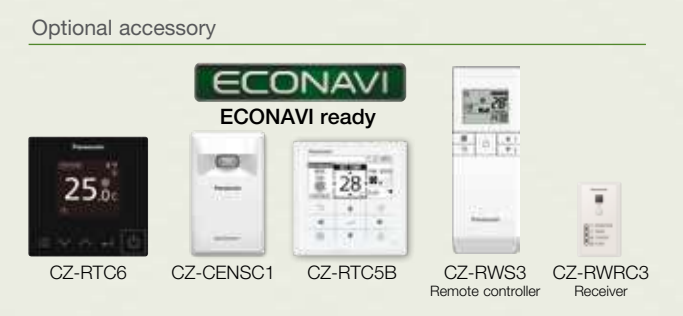

Technical focus

- Ultra-slim profile: 200 mm for all models
- DC fan motor greatly reduces power consumption
- Ideal for hotel application with very narrow false ceilings
- Easy maintenance and service by external electrical box
- 29 Pa static pressure enables ductwork to be fitted.
- Drain pump (optional)

Ultra-slim profile for all models

200mm height for all models allows installation in very narrow ceilings.



Drain pump with increased power! (optional)

Using the optional high-lift drain pump, the drain piping rise height can be increased to 700 mm from the drain pipe port.



CZ-73DMZ1

| Model Name | | S-22MZ1H4A | S-28MZ1H4A | S-36MZ1H4A | S-45MZ1H4A | S-56MZ1H4A | S-60MZ1H4A | S-73MZ1H4A |
|------------------------------------|-----------------------------|-----------------------------------|------------------------------|------------------------------|------------------------------|------------------------------|------------------------------|------------------------------|
| Power source | | 220/230/240 V, 1 phase - 50/60 Hz | | | | | | |
| Cooling capacity | kW | 2.2 | 2.8 | 3.6 | 4.5 | 5.6 | 6.0 | 7.3 |
| | BTU/h | 7,500 | 9,500 | 12,200 | 15,300 | 19,100 | 20,500 | 24,900 |
| Heating capacity | kW | 2.5 | 3.2 | 4.2 | 5.1 | 6.4 | 7.1 | 8.0 |
| | BTU/h | 8,500 | 10,900 | 14,300 | 17,400 | 21,800 | 24,200 | 27,300 |
| Power input | Cooling kW | 0.075/0.075/0.075 | 0.080/0.080/0.080 | 0.085/0.085/0.085 | 0.095/0.095/0.095 | 0.100/0.100/0.100 | 0.100/0.100/0.100 | 0.125/0.125/0.125 |
| | Heating kW | 0.075/0.075/0.075 | 0.080/0.080/0.080 | 0.085/0.085/0.085 | 0.095/0.095/0.095 | 0.100/0.100/0.100 | 0.100/0.100/0.100 | 0.125/0.125/0.125 |
| Running current | Cooling A | 0.50/0.47/0.45 | 0.55/0.52/0.50 | 0.60/0.57/0.55 | 0.70/0.68/0.65 | 0.75/0.72/0.70 | 0.75/0.72/0.70 | 0.80/0.78/0.75 |
| | Heating A | 0.50/0.47/0.45 | 0.55/0.52/0.50 | 0.60/0.57/0.55 | 0.70/0.68/0.65 | 0.75/0.72/0.70 | 0.75/0.72/0.70 | 0.80/0.78/0.75 |
| Fan | Type | Sirocco fan | Sirocco fan | Sirocco fan | Sirocco fan | Sirocco fan | Sirocco fan | Sirocco fan |
| | Air flow rate (H/M/L) m³/h | 480/420/360 | 600/540/420 | 600/540/420 | 690/630/510 | 720/660/540 | 870/750/630 | 1,080/840/660 |
| | L/s | 133/117/100 | 167/150/117 | 167/150/117 | 192/175/142 | 200/183/150 | 242/208/175 | 300/233/183 |
| | Motor output W | 60 | 60 | 60 | 60 | 60 | 60 | 60 |
| | External static pressure Pa | 10-30 | 10-30 | 10-30 | 10-30 | 10-30 | 10-30 | 10-30 |
| Sound power level (H/M/L) dB | | 50/49/47 | 52/51/49 | 54/52/50 | 56/54/52 | 57/55/53 | 60/57/55 | 62/60/58 |
| Sound pressure level (H/M/L) dB(A) | | 28/27/25 | 30/29/27 | 32/30/28 | 34/32/30 | 35/33/31 | 38/35/33 | 40/38/36 |
| Dimensions H x W x D mm | | 200x830x500 | 200x830x500 | 200x830x500 | 200x830x500 | 200x830x500 | 200x830x500 | 200x1,050x550 |
| | Liquid mm (inches) | Ø6.35 (Ø1/4) | Ø6.35 (Ø1/4) | Ø6.35 (Ø1/4) | Ø6.35 (Ø1/4) | Ø6.35 (Ø1/4) | Ø9.52 (Ø3/8) | Ø9.52 (Ø3/8) |
| Pipe connections | Gas mm (inches) | Ø12.7 (Ø1/2) | Ø12.7 (Ø1/2) | Ø12.7 (Ø1/2) | Ø12.7 (Ø1/2) | Ø12.7 (Ø1/2) | Ø15.88 (Ø5/8) | Ø15.88 (Ø5/8) |
| | Drain piping | O.D. Ø20.5 mm / I.D. Ø15.5mm | O.D. Ø20.5 mm / I.D. Ø15.5mm | O.D. Ø20.5 mm / I.D. Ø15.5mm | O.D. Ø20.5 mm / I.D. Ø15.5mm | O.D. Ø20.5 mm / I.D. Ø15.5mm | O.D. Ø20.5 mm / I.D. Ø15.5mm | O.D. Ø20.5 mm / I.D. Ø15.5mm |
| Net weight kg | | 17 | 17 | 18 | 18 | 18 | 18 | 24 |

| GLOBAL REMARKS | Rated conditions: | |
|----------------|-------------------------|-------------------|
| | Indoor air temperature | 27°C DB / 19°C WB |
| | Outdoor air temperature | 35°C DB / 24°C WB |

Specifications are subject to change without notice.

Z1 TYPE SLIM LOW STATIC DUCTED TWENTY SERIES Dimensions

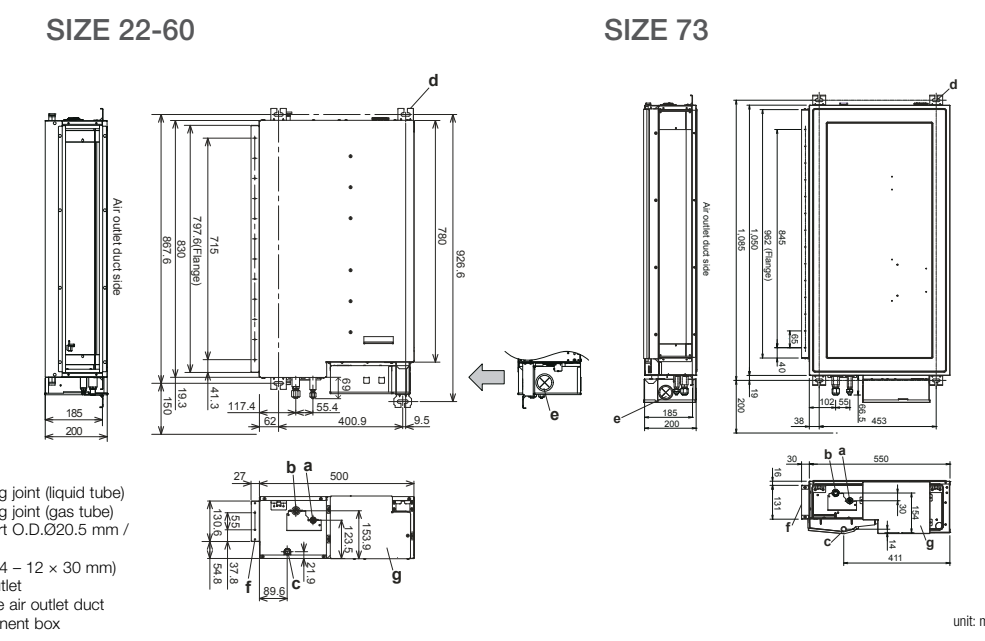

- a) Refrigerant tubing joint (liquid tube)
- b) Refrigerant tubing joint (gas tube)
- c) Bottom drain port O.D.Ø20.5 mm / I.D. Ø15.5mm
- d) Suspension lug (4 - 12 x 30 mm)
- e) Power supply outlet
- f) Flange for flexible air outlet duct
- g) Electrical component box

unit: mm

E2 TYPE High Static Ducted



Concealed duct / Air conditioning mode

High static and large airflow ducted for exceptional installation flexibility.



S-180ME2E5 / S-224ME2E5 / S-280ME2E5

Optional accessory

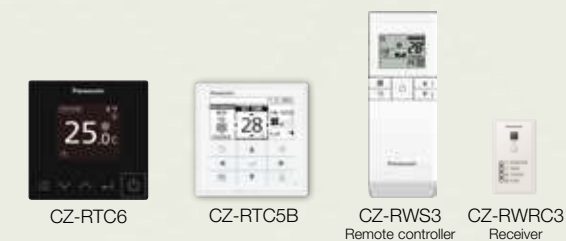

Technical focus

- Design flexibility thanks to high static pressure and large air volume
- DC motor equipped
- Power input 45% less (compared to E1 type)
- Discharge air temperature control to reduce cold drafts during heating operation
- Configurable air temperature control
- Available Fresh Air Intake mode (See page 80-81)

3-step static pressure set up

You can select between the three Static Pressure modes of 270 Pa/140 Pa/60(72*) Pa for extra installation flexibility.

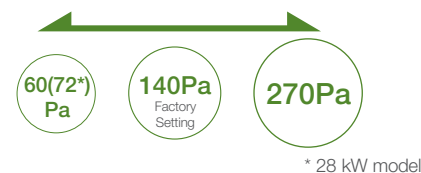

* 28 kW model

Max. 270 Pa static pressure setting

A maximum static pressure setting of a high 270 Pa enables the use of long ducts for installation in a wide range of spaces. Ideal for large-scale offices, restaurants and other facilities.

Sensible cooling 5-10% improved

New heat exchanger with ϕ 7mm pipe that increases the heat transfer surface to improve sensible cooling (5-10% improvement)

No Rap Valve Kit required

Thanks to improved performance, a Rap Valve Kit (CZ-P160RVK2) is no longer required.



Discharge air temperature control

- Equipped with 4 sensors (Intake/ Discharge)
- Able to control discharge air temperature for accurate room temperature control.
- Possible to reduce cold drafts during heating operation.

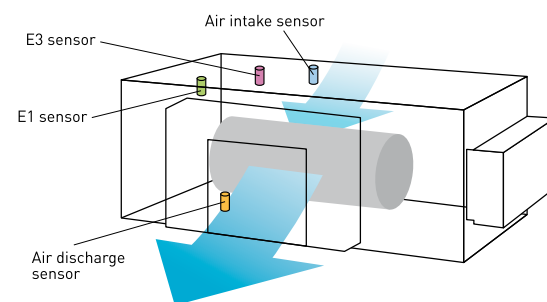

| Model Name | | S-180ME2E5 | S-224ME2E5 | S-280ME2E5 |
|------------------------------------|---|--|-------------------|-------------------|
| Power source | | 220/230/240 V, 1 phase - 50 Hz, 220/230 V, 1 phase - 60 Hz | | |
| Cooling capacity | kW | 18.0 | 22.4 | 28.0 |
| | BTU/h | 61,400 | 76,400 | 95,500 |
| Heating capacity | kW | 20.0 | 25.0 | 31.5 |
| | BTU/h | 68,200 | 85,300 | 107,500 |
| Power input | Cooling kW | 0.400 | 0.440 | 0.715 |
| | Heating kW | 0.400 | 0.440 | 0.715 |
| Running current | Cooling A | 2.40/2.30/2.20 | 2.55/2.45/2.35 | 3.95/3.85/3.70 |
| | Heating A | 2.40/2.30/2.20 | 2.55/2.45/2.35 | 3.95/3.85/3.70 |
| Fan | Type | Sirocco fan | | |
| | Air flow rate (H/M/L) m ³ /h | 2,940/2,640/2,340 | 3,360/3,060/2,640 | 4,320/3,780/3,180 |
| | L/s | 817/733/650 | 933/850/733 | 1,200/1,050/883 |
| | Motor output kW | 0.560 x 2 | | |
| | External static pressure Pa | 140 (60/270) | | |
| Sound power level (H/M/L) dB | | 76/74/72 | 77/75/73 | 81/79/75 |
| Sound pressure level (H/M/L) dB(A) | | 44/42/40 | 45/43/41 | 49/47/43 |
| Dimensions H x W x D mm | | 479 x 1,453 x 1,205 | | |
| | | | | |
| Pipe connections | Liquid inches (mm) | Ø9.52 (3/8) | | |
| | Gas inches (mm) | Ø19.05 (3/4) | | |
| | Drain piping | VP-25 | | |
| Net weight kg | | 102 | 102 | 106 |

| GLOBAL REMARKS | Rated conditions: | Cooling | Heating |
|----------------|-------------------------|-------------------|-----------------|
| | Indoor air temperature | 27°C DB / 19°C WB | 20°C DB |
| | Outdoor air temperature | 35°C DB / 24°C WB | 7°C DB / 6°C WB |

E2 TYPE HIGH STATIC DUCTED Dimensions

- 1 Refrigerant piping (liquid pipes) Ø9.52
- 2 Refrigerant piping (gas pipes) 180 & 224 type: Ø19.05, 280 type: Ø22.22
- 3 Power supply outlet (Ø25 grommet, rubber)
- 4 Power supply outlet (spare) (Ø30 knock-out)
- 5 Optional outlet for piping
- 6 Drain port 25 A, male thread
- 7 Duct connection for suction
- 8 Duct connection for discharge

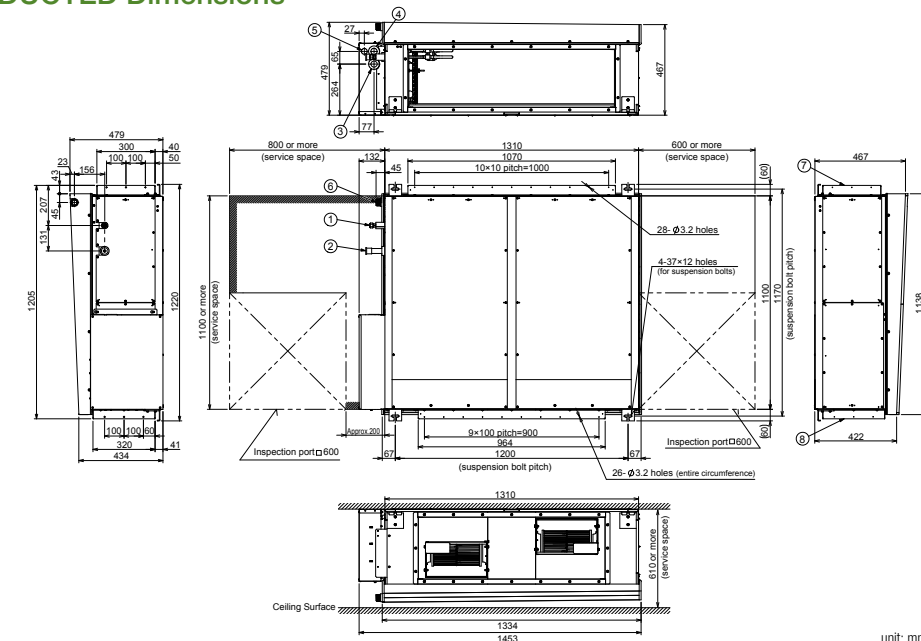

unit: mm

E2 TYPE Energy Saving High Fresh Air Ducted

Concealed duct high-static pressure



High static and large airflow ducted for exceptional installation flexibility.



S-224ME2E5 / S-280ME2E5

Optional accessory

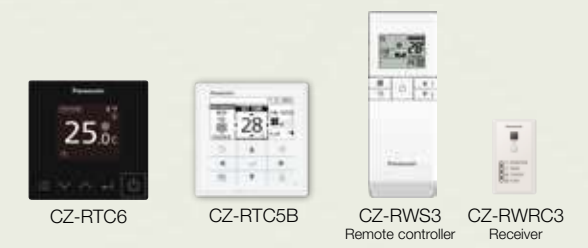

Technical focus

- 100% fresh air intake for ventilation purpose
- Design flexibility with high static pressure and large air volume
- DC motor equipped
- Power input 45% less (compared to H1 type)
- Discharge air temperature control to reduce cold drafts during heating operation
- Configurable air temperature control

High Fresh System

High Fresh System enables delivery of fresh outside air at almost the same temperature and humidity as indoor air without putting a burden on air conditioning.
 * Capable of treating outdoor air only. Indoor air conditioner units are required to adjust indoor air temperature.

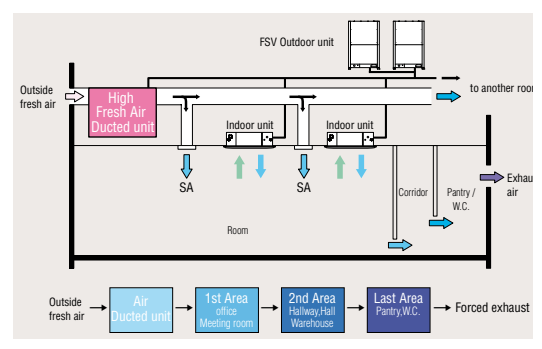

Mix operation unit with standard indoor units

Possible to combine High Fresh Air ducted indoor unit and standard air ducted indoor units.
 When other indoor units are connected in same circuit, keep following capacity ratio.
 E2 type/Outdoor unit < 30%, and Total of indoors(incl. E2)/outdoor < 100%

Discharge air temperature control

- Equipped with 4 sensors (Intake/ Discharge)
- Able to control discharge air temperature for accurate room temperature control.
- Possible to reduce cold drafts during heating operation.

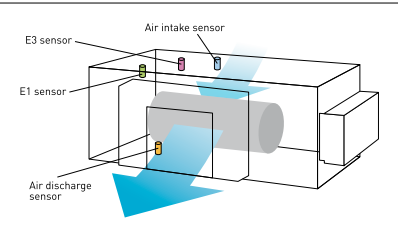

Remark For High Static Ducted Series

| Model | Operation | Rap valve kit CZ-P160RVK2 | 3way control PCB CZ-CAPE2 | 3way valve kit CZ-P160HR3 | Distribution Joint kit <2pipes> CZ-P160BK2 for 22.4kW unit or less CZ-P680BK2 for more than 22.4kW | Distribution Joint kit <3pipes> CZ-P224BH2 for 22.4kW unit CZ-P680BH2 for 28.0kW unit |
|-------------------------------------|---------------|------------------------------|------------------------------|------------------------------|---|--|
| E2 Type | Cooling Only | - | - | - | - | - |
| Energy Saving High-Fresh Air Ducted | Cool or Heat | 2pcs | 2pcs | - | 2pcs | - |
| | Heat Recovery | - | 2pcs | 2pcs | 1pc | 1pc |

| Model Name | | S-224ME2E5 | S-280ME2E5 |
|----------------------|---------------------------------|--|----------------|
| Power source | | 220/230/240 V, 1 phase - 50 Hz, 220/230 V, 1 phase - 60 Hz | |
| Cooling capacity | kW | 22.4 | 28.0 |
| | BTU/h | 76,400 | 95,500 |
| Heating capacity | kW | 21.2 | 26.5 |
| | BTU/h | 72,300 | 90,400 |
| Power input | Cooling kW | 0.290 | 0.350 |
| | Heating kW | 0.290 | 0.350 |
| Running current | Cooling A | 1.90/1.85/1.80 | 2.30/2.20/2.10 |
| | Heating A | 1.90/1.85/1.80 | 2.30/2.20/2.10 |
| Fan | Type | Sirocco fan | |
| | Air flow rate m ³ /h | 1,700 | 2,100 |
| | L/s | 472 | 583 |
| | Motor output kW | 0.560 x 2 | 0.750 x 2 |
| | External static pressure Pa | 200 | 200 |
| Sound power level | dB | 75 | 76 |
| Sound pressure level | dB(A) | 43 | 44 |
| Dimensions | H x W x D mm | 479 x 1,453 x 1,205 | |
| | Liquid inches (mm) | Ø9.52 (Ø3/8) | Ø9.52 (Ø3/8) |
| Pipe connections | Gas inches (mm) | Ø19.05 (Ø3/4) | Ø22.22 (Ø7/8) |
| | Drain piping | VP-25 | |
| Net weight | kg | 102 | 106 |

GLOBAL REMARKS: Rated conditions: Cooling 33°C DB / 28°C WB, Heating 0°C DB / -2.9°C WB. Specifications are subject to change without notice.

E2 TYPE HIGH STATIC DUCTED Dimensions

- 1 Refrigerant piping (liquid pipes) Ø9.52
- 2 Refrigerant piping (gas pipes) 224 type: Ø19.05, 280 type: Ø22.22
- 3 Power supply outlet (Ø25 grommet, rubber)
- 4 Power supply outlet (spare) (Ø30 knock-out)
- 5 Optional outlet for piping
- 6 Drain port 25 A, male thread
- 7 Duct connection for suction
- 8 Duct connection for discharge

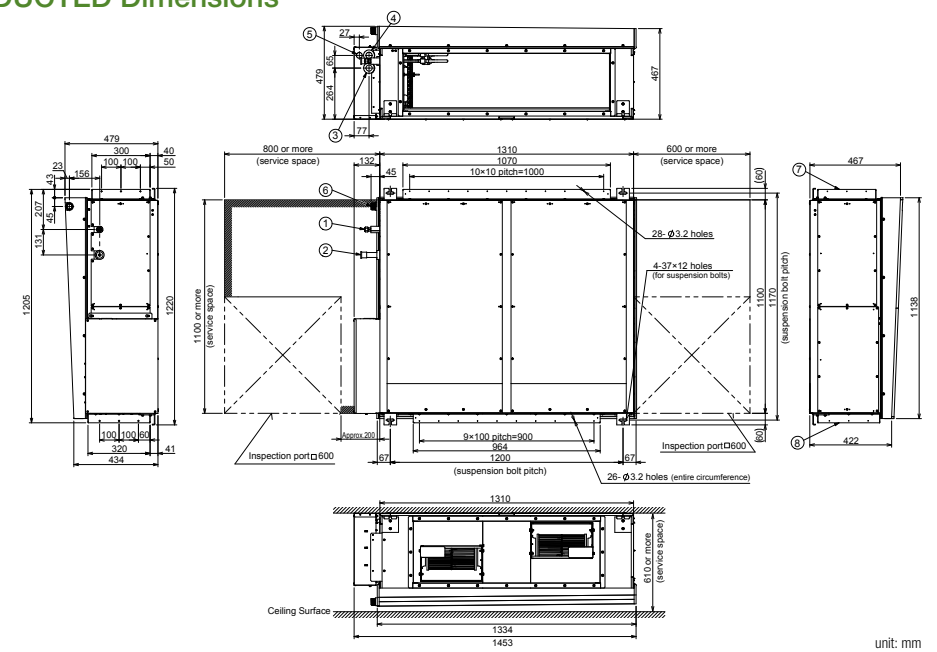

E1 TYPE High Static Ducted

Concealed duct high-static pressure

The E1 range of ducted units offers improved design flexibility for extended duct layouts as a result of their increased external static pressures.



Technical focus

- Complete flexibility for ductwork design
- Can be located into a weatherproof housing for external installation
- Discharge air temperature control to reduce cold drafts during heating operation
- Configurable air temperature control

System example

An inspection port (450 x 450 mm or more) is required at the lower side of the indoor unit body (field supply).

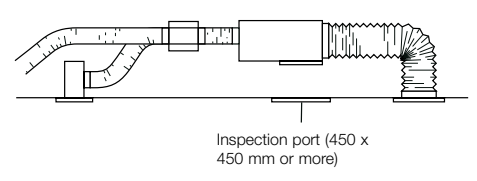

Discharge air temperature control

- Equipped with 4 sensors (Intake/ Discharge)
- Able to control discharge air temperature for accurate room temperature control.
- Possible to reduce cold drafts during heating operation.

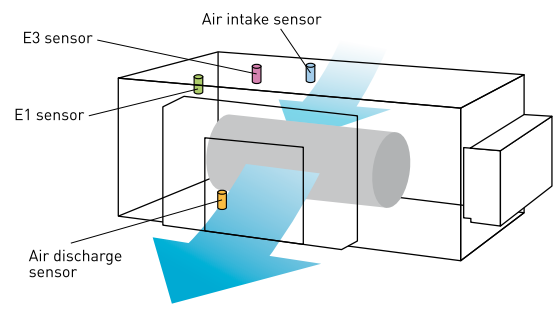

Remark For High Static Ducted Series

| Model | Operation | Rap valve kit CZ-P160RVK2 | 3way control PCB CZ-CAPE2 | 3way valve kit CZ-P160HR3 | Distribution Joint kit <2pipes> CZ-P160BK2 for 22.4kW unit or less CZ-P680BK2 for more than 22.4kW | Distribution Joint kit <3pipes> CZ-P224BH2 for 22.4kW unit CZ-P680BH2 for 28.0kW unit |
|---|---------------|------------------------------|------------------------------|------------------------------|---|--|
| E1 Type High Static Ducted (Only for S-224,S-280) | Cooling Only | - | - | - | - | - |
| | Cool or Heat | 2pcs | - | - | 2pcs | - |
| | Heat Recovery | - | - | 2pcs | 1pc | 1pc |

| Model Name | | S-73ME1E5 | S-106ME1E5 | S-140ME1E5 | S-224ME1E5 | S-280ME1E5 | |
|------------------------------|--------------------------|-----------------------------------|-------------------|-------------------|-------------------|--------------------------------|---------------------|
| Power source | | 220/230/240 V, 1 phase - 50/60 Hz | | | | 220/230/240 V, 1 phase - 50 Hz | |
| Cooling capacity | kW | 7.3 | 10.6 | 14.0 | 22.4 | 28.0 | |
| | BTU/h | 25,000 | 36,000 | 47,800 | 76,400 | 95,500 | |
| Heating capacity | kW | 8.0 | 11.4 | 16.0 | 25.0 | 31.5 | |
| | BTU/h | 27,000 | 39,000 | 54,600 | 85,300 | 107,500 | |
| Power input | Cooling kW | 0.480/0.505/0.530 | 0.520/0.545/0.570 | 0.600/0.660/0.710 | 0.870/0.900/0.930 | 1.270/1.330/1.390 | |
| | Heating kW | 0.480/0.505/0.530 | 0.520/0.545/0.570 | 0.600/0.660/0.710 | 0.870/0.900/0.930 | 1.270/1.330/1.390 | |
| Running current | Cooling A | 2.29/2.30/2.31 | 2.46/2.46/2.47 | 2.80/2.90/3.00 | 4.05/4.06/4.07 | 6.04/6.06/6.07 | |
| | Heating A | 2.29/2.30/2.31 | 2.46/2.46/2.47 | 2.80/2.90/3.00 | 4.05/4.06/4.07 | 6.04/6.06/6.07 | |
| Fan | Type | Sirocco fan | Sirocco fan | Sirocco fan | Sirocco fan | Sirocco fan | |
| | Air flow rate (H/M/L) | m³/h | 1,380/1,320/1,260 | 1,800/1,680/1,500 | 2,160/2,100/1,980 | 3,360/3,190/2,980 | 4,320/4,200/3,960 |
| | | L/s | 383/367/350 | 500/467/417 | 600/583/550 | 933/886/828 | 1,200/1,167/1,100 |
| | Motor output | kW | 0.2 | 0.2 | 0.35 | 0.2 | 0.4 |
| | External static pressure | Pa | 186 | 176 | 167 | 176 | 216 (235)* |
| Sound power level (H/M/L) | dB | 55/54/53 | 56/55/53 | 58/57/55 | 59/58/57 | 62/61/60 | |
| Sound pressure level (H/M/L) | dB(A) | 44/43/42 | 45/44/42 | 47/46/44 | 48/47/46 | 51/50/49 (52/51/50)* | |
| Dimensions | H x W x D | mm | 420 x 1,065 x 620 | 420 x 1,065 x 620 | 450 x 1,065 x 620 | 479 x 1,428 x 1,230 | 479 x 1,428 x 1,230 |
| | Liquid | mm (inches) | Ø9.52 (Ø3/8) | Ø9.52 (Ø3/8) | Ø9.52 (Ø3/8) | Ø9.52 (Ø3/8) | Ø9.52 (Ø3/8) |
| Pipe connections | Gas | mm (inches) | Ø15.88 (Ø5/8) | Ø15.88 (Ø5/8) | Ø15.88 (Ø5/8) | Ø19.05 (Ø3/4) | Ø22.22 (Ø7/8) |
| | Drain piping | | VP-25 | VP-25 | VP-25 | VP-25 | VP-25 |
| Net weight | kg | 47 | 50 | 54 | 110 | 120 | |

| GLOBAL REMARKS | Rated conditions: | Cooling | Heating |
|----------------|-------------------------|-------------------|-----------------|
| | Indoor air temperature | 27°C DB / 19°C WB | 20°C DB |
| | Outdoor air temperature | 35°C DB / 24°C WB | 7°C DB / 6°C WB |

Specifications are subject to be changed without notice.
* Via Jumper setting.

E1 TYPE HIGH STATIC DUCTED Dimensions

- 1 Refrigerant liquid line (Ø9.52)
- 2 Refrigerant gas line (Ø15.88)
- 3 Power supply entry
- 4 Drain connection (20A / VP25)
- 5 Duct connection for suction
- 6 Duct connection for discharge

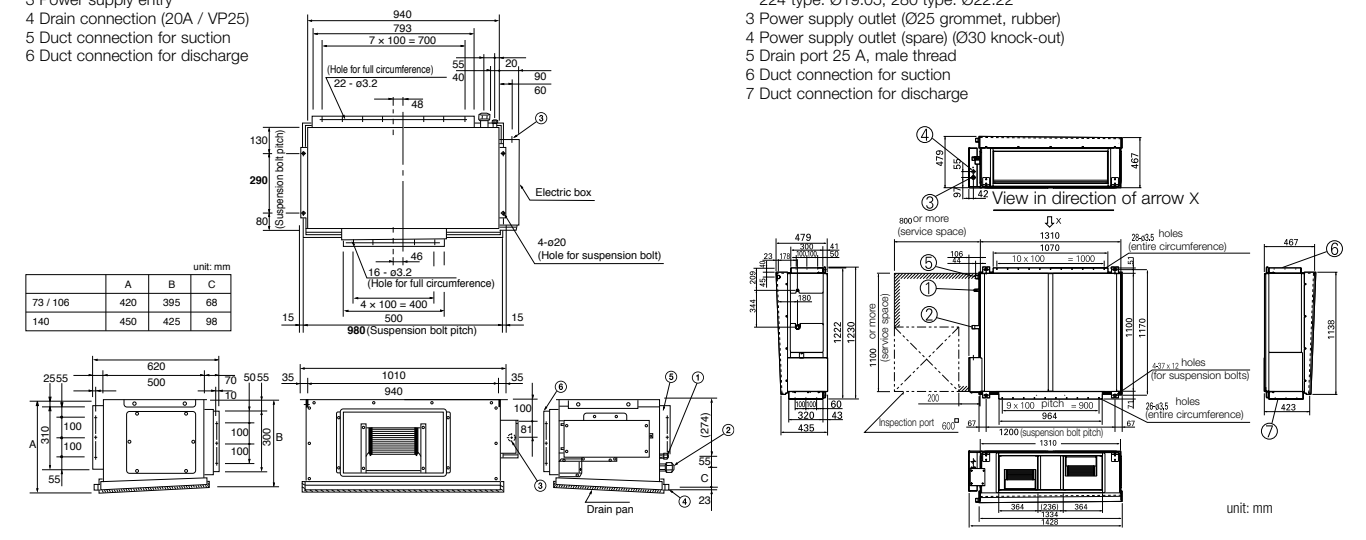

- 1 Refrigerant piping (liquid pipes) Ø9.52
- 2 Refrigerant piping (gas pipes) 224 type: Ø19.05, 280 type: Ø22.22
- 3 Power supply outlet (Ø25 grommet, rubber)
- 4 Power supply outlet (spare) (Ø30 knock-out)
- 5 Drain port 25 A, male thread
- 6 Duct connection for suction
- 7 Duct connection for discharge

H1 TYPE High-Fresh Air Ducted Concealed duct

High static and large airflow ducted for exceptional installation flexibility.



Technical focus

- 100% fresh Air intake for ventilation purpose
- Design flexibility thanks to high static pressure and large air volume
- Discharge air temperature control to reduce cold drafts during heating operation
- Configurable air temperature control

High Fresh System

High Fresh system enables delivery of fresh outside air at almost the same temperature and humidity as indoor air without putting a burden on air conditioning.
 * Capable of treating outdoor air only.
 Indoor air conditioner units are required to adjust indoor air temperature.

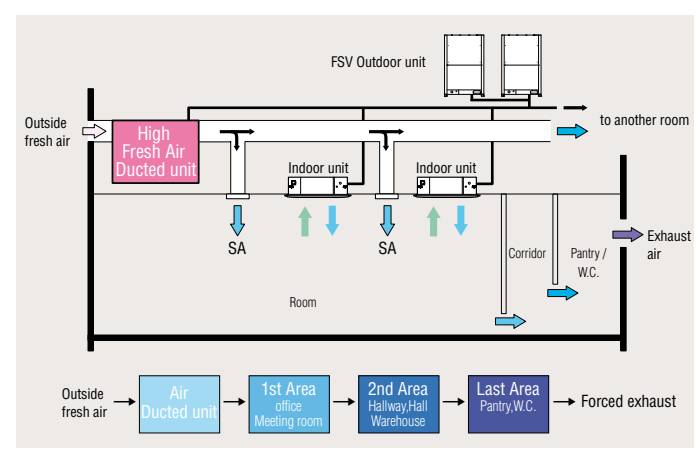

Mix operation unit with standard indoor units

Possible to combine High Fresh Air ducted indoor unit and standard air ducted indoor units.

When other indoor units are connected in same circuit, keep following capacity ratio.
 H1 type/Outdoor unit < 30%, and Total of indoors(incl. H1)/outdoor < 100%

Remark For High Static Ducted Series

| Model | Operation | Rap valve kit CZ-P160RVK2 | 3way control PCB CZ-CAPE2 | 3way valve kit CZ-P160HR3 | Distribution Joint kit <2pipes> CZ-P160BK2 for 22.4kW unit or less CZ-P680BK2 for more than 22.4kW | Distribution Joint kit <3pipes> CZ-P224BH2 for 22.4kW unit CZ-P680BH2 for 28.0kW unit |
|-------------------------------|---------------|------------------------------|------------------------------|------------------------------|---|--|
| H1 Type High-Fresh Air Ducted | Cooling Only | - | - | - | - | - |
| | Cool or Heat | 2pcs | - | - | 2pcs | - |
| | Heat Recovery | - | - | 2pcs | 1pc | 1pc |

| Model Name | | S-140MH1H5 | S-224MH1H5 | S-280MH1H5 |
|------------------------------|--------------------|--------------------------------|---------------------|---------------------|
| Power source | | 220/230/240 V, 1 phase - 50 Hz | | |
| Cooling capacity | kW | 14.0 | 22.4 | 28.0 |
| | BTU/h | 47,800 | 76,400 | 95,500 |
| Heating capacity | kW | 13.2 | 21.2 | 26.5 |
| | BTU/h | 45,000 | 72,300 | 90,400 |
| Power input | Cooling kW | 0.430/0.430/0.430 | 0.670/0.670/0.670 | 0.730/0.730/0.730 |
| | Heating kW | 0.430/0.430/0.430 | 0.670/0.670/0.670 | 0.730/0.730/0.730 |
| Running current | Cooling A | 2.0/1.9/1.9 | 3.2/3.1/3.0 | 3.6/3.4/3.3 |
| | Heating A | 2.0/1.9/1.9 | 3.2/3.1/3.0 | 3.6/3.4/3.3 |
| Fan | Type | Sirocco fan | | |
| | Air flow rate m³/h | 1,560 | 1,800 | 2,100 |
| | L/s | 433 | 500 | 583 |
| | Motor output kW | 0.3 | 0.38 | 0.38 |
| Sound power level (H/M/L) | dB | 75/76/76 | 78/79/79 | 79/80/80 |
| Sound pressure level (H/M/L) | dB(A) | 43/44/44 | 46/47/47 | 47/48/48 |
| Dimensions H x W x D | mm | 420 x 1,065 x 620 | 479 x 1,428 x 1,230 | 479 x 1,428 x 1,230 |
| | Liquid mm (inches) | Ø9.52 (Ø3/8) | Ø12.7 (Ø1/2) | Ø12.7 (Ø1/2) |
| Pipe connections | Gas mm (inches) | Ø15.88 (Ø5/8) | Ø25.4 (Ø1) | Ø25.4 (Ø1) |
| | Drain piping | VP-25 | | |
| Net weight | kg | 50 | 110 | 110 |

| GLOBAL REMARKS | Rated conditions: | | Specifications are subject to change without notice. |
|----------------|-------------------------|-------------------|--|
| | Cooling | Heating | |
| | Outdoor air temperature | 33°C DB / 28°C WB | 0°C DB / -2.9°C WB |

H1TYPE HIGH-FRESH AIR DUCTED Dimensions

- 1 Refrigerant liquid line
- 2 Refrigerant gas line
- 3 Power supply entry
- 4 Drain connection
- 5 Duct connection for suction
- 6 Duct connection for discharge

SIZE 140

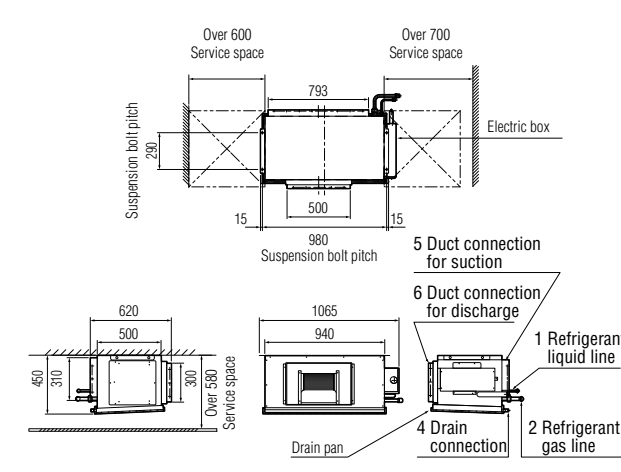

SIZE 224-280

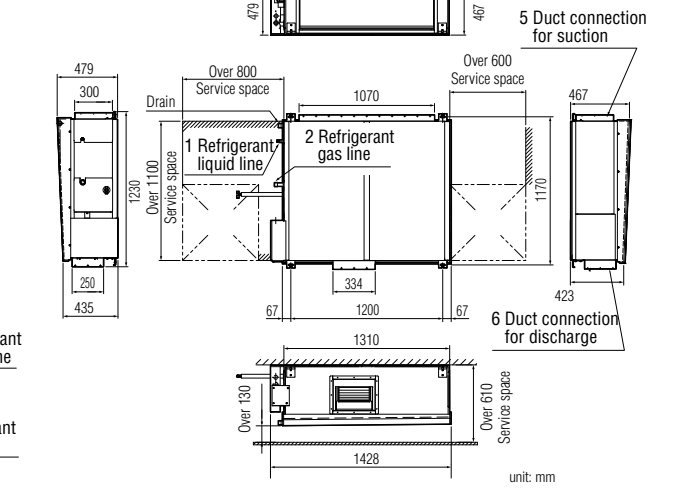

K2_{TYPE} Wall Mounted



The K2 type wall mounted unit has a stylish smooth design with a washable front panel. Small, lightweight and low noise level makes it ideal for small offices and other commercial applications.



S-22MK2E5A / S-28MK2E5A
S-36MK2E5A



S-45MK2E5A / S-56MK2E5A
S-73MK2E5A / S-106MK2E5A

Optional accessory



*Receiver is included in the wall mounted indoor unit.



Self-diagnosing Function



Automatic Fan Operation



Dry mode



Intelligent Auto Swing



Automatic Restart Function



Auto Swing (Auto Flap Control)

Technical focus

- Closed discharge port when not in use
- Lighter and smaller units make installation easy
- Quiet operation
- Smooth and durable design
- Piping outlet in six directions
- Washable front panel
- Air distribution is automatically altered depending on the operational mode of the unit

Noise reducing external valve kit

To reduce noise level of expansion valve. (Optional accessory)



CZ-P56SVK2 (for 22 - 56 type)
CZ-P160SVK2 (for 73* - 106 type)

*When the pipe diameter is (Liquid) Ø6.35 - (Gas) Ø12.7, please use CZ-P56SVK2.

Closed discharge port

When the unit is turned off, the flap closes completely to prevent entry of dust into the unit and to keep the equipment clean.

Compact indoor units make the installation easy

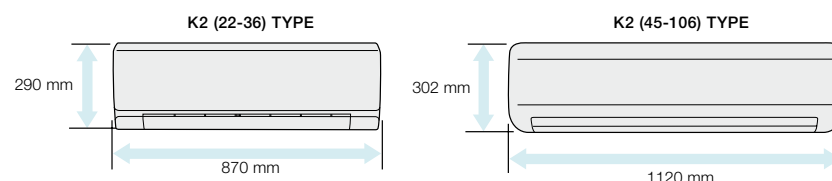

Quiet operation

Low operating noise level makes these units ideal for hotels and hospital applications.

Smooth and durable design

The smooth cover means these units match most modern interiors. Their compact size enables them to blend in, even in small spaces.

Piping outlet in six directions

Piping outlet is possible in the six directions of right, right rear, right bottom, left, left rear, left bottom, making installation easier.

Washable front panel

The indoor unit's front panel can be easily removed and washed for trouble-free maintenance.



Air distribution is automatically adjusted depending on the operational mode of the unit

Air outlet angle is automatically adjusted for cooling and heating operation.

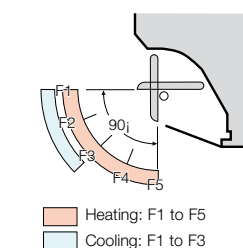

K2_{TYPE} Wall Mounted

| Model Name | | S-22MK2E5A | S-28MK2E5A | S-36MK2E5A | S-45MK2E5A | |
|------------------------------|-----------------------|-----------------------------------|-------------------|-------------------|-------------------|-------------------|
| Power source | | 220/230/240 V, 1 phase - 50/60 Hz | | | | |
| Cooling capacity | kW | 2.20 | 2.80 | 3.60 | 4.5 | |
| | BTU/h | 7,500 | 9,600 | 12,300 | 15,400 | |
| Heating capacity | kW | 2.50 | 3.20 | 4.20 | 5.0 | |
| | BTU/h | 8,500 | 10,900 | 14,300 | 17,100 | |
| Power input | Cooling kW | 0.025/0.025/0.025 | 0.025/0.025/0.025 | 0.030/0.030/0.030 | 0.030/0.030/0.030 | |
| | Heating kW | 0.025/0.025/0.025 | 0.025/0.025/0.025 | 0.030/0.030/0.030 | 0.030/0.030/0.030 | |
| Running current | Cooling A | 0.21 | 0.23 | 0.25 | 0.33/0.32/0.31 | |
| | Heating A | 0.21 | 0.23 | 0.25 | 0.33/0.32/0.31 | |
| Fan | Type | Cross-flow fan | Cross-flow fan | Cross-flow fan | Cross-flow fan | |
| | Air flow rate (H/M/L) | m ³ /h | 540/450/390 | 570/498/390 | 654/540/390 | 870/750/600 |
| | | L/s | 150/125/108 | 158/138/108 | 182/150/108 | 242/208/167 |
| | Motor output | kW | 0.03 | 0.03 | 0.03 | 0.054 |
| Sound power level (H/M/L) | dB | 51/48/44 | 52/49/44 | 55/51/44 | 53/50/48 | |
| Sound pressure level (H/M/L) | dB(A) | 36/33/29 | 37/34/29 | 40/36/29 | 38/35/33 | |
| Dimensions | H x W x D | mm | 290 x 870 x 214 | 290 x 870 x 214 | 290 x 870 x 214 | 302 x 1,120 x 236 |
| | Liquid | mm (inches) | Ø6.35 (Ø1/4) | Ø6.35 (Ø1/4) | Ø6.35 (Ø1/4) | Ø6.35 (Ø1/4) |
| Pipe connections | Gas | mm (inches) | Ø12.7 (Ø1/2) | Ø12.7 (Ø1/2) | Ø12.7 (Ø1/2) | Ø12.7 (Ø1/2) |
| | Drain piping | mm | Ø18 | Ø18 | Ø18 | Ø18 |
| Net weight | kg | 9 | 9 | 9 | 13 | |

| GLOBAL REMARKS | Rated conditions: | |
|----------------|-------------------------|-------------------|
| | Indoor air temperature | 27°C DB / 19°C WB |
| | Outdoor air temperature | 35°C DB / 24°C WB |

Specifications are subject to change without notice.

| | Cooling | Heating |
|-------------------------|-------------------|-----------------|
| Indoor air temperature | 27°C DB / 19°C WB | 20°C DB |
| Outdoor air temperature | 35°C DB / 24°C WB | 7°C DB / 6°C WB |

| | S-56MK2E5A | S-73MK2E5A | S-106MK2E5A |
|------------------------------|-----------------------------------|-------------------|-------------------|
| Power source | 220/230/240 V, 1 phase - 50/60 Hz | | |
| Cooling capacity | 5.6 | 7.3 | 10.6 |
| BTU/h | 19,100 | 24,900 | 36,200 |
| Heating capacity | 6.3 | 8.0 | 11.4 |
| BTU/h | 21,500 | 27,300 | 38,900 |
| Power input | 0.035/0.035/0.035 | 0.055/0.055/0.055 | 0.080/0.080/0.080 |
| Heating kW | 0.035/0.035/0.035 | 0.055/0.055/0.055 | 0.080/0.080/0.080 |
| Cooling A | 0.36/0.35/0.34 | 0.52/0.51/0.50 | 0.72/0.70/0.68 |
| Heating A | 0.36/0.35/0.34 | 0.52/0.51/0.50 | 0.72/0.70/0.68 |
| Type | Cross-flow fan | Cross-flow fan | Cross-flow fan |
| Air flow rate (H/M/L) | 960/840/720 | 1,170/1,020/840 | 1,290/1,110/900 |
| L/s | 267/233/200 | 325/283/233 | 358/308/250 |
| Motor output | 0.054 | 0.054 | 0.054 |
| Sound power level (H/M/L) | 55/52/50 | 62/59/55 | 64/61/57 |
| Sound pressure level (H/M/L) | 40/37/35 | 47/44/40 | 49/46/42 |
| Dimensions | 302 x 1,120 x 236 | 302 x 1,120 x 236 | 302 x 1,120 x 236 |
| Liquid | Ø6.35 (Ø1/4) | Ø9.52 (Ø3/8) | Ø9.52 (Ø3/8) |
| Gas | Ø12.7 (Ø1/2) | Ø15.88 (Ø5/8) | Ø15.88 (Ø5/8) |
| Drain piping | Ø18 | Ø18 | Ø18 |
| Net weight | 13 | 14 | 14 |

K2 (22-36) TYPE WALL MOUNTED Dimensions

SIZE 22-36

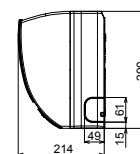
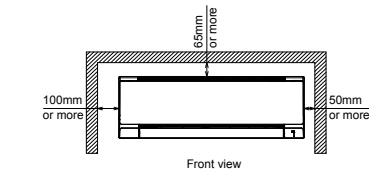
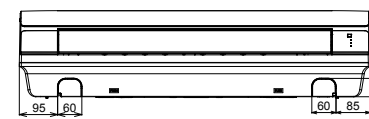
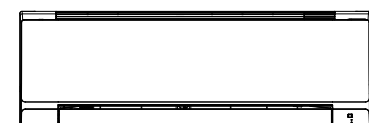
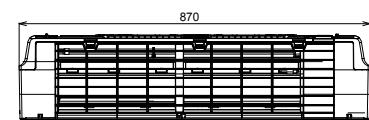

- 1 Refrigerant tubing (liquid tube) ø6.35(flared)
- 2 Refrigerant tubing (gas tube) ø12.7(flared)
- 3 Drain hose (outer dia. ø16)
- 4 Rear panel (PL BACK)
- 5 Rear panel fixing holes (ø5 holes or 5X13 oval holes)
- 6 Tubing and wiring holes (ø70)

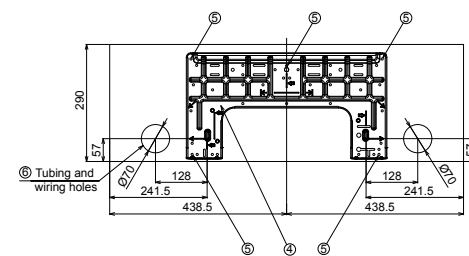
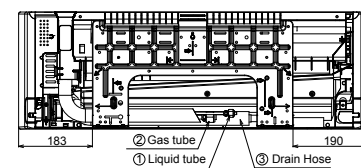

unit: mm

K2 (45-106) TYPE WALL MOUNTED Dimensions

SIZE 45-106

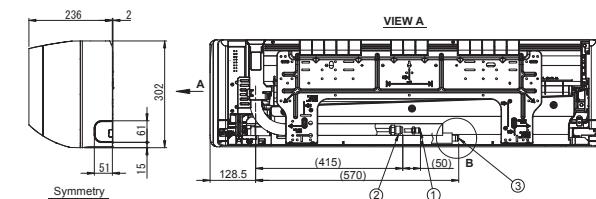
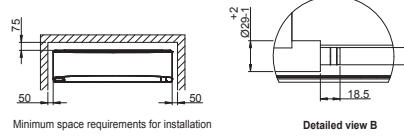
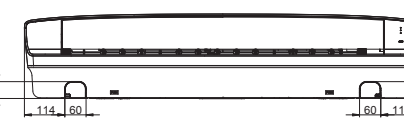
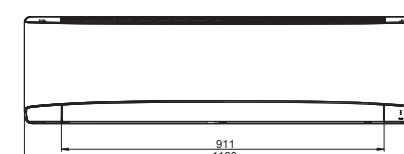

- 1 Refrigerant tubing (liquid tube) Type 45-56 Ø6.35 (flared) Type 73-106 Ø9.52 (flared)
- 2 Refrigerant tubing (gas tube) Type 45-56 Ø12.7 (flared) Type 73-106 Ø15.88 (flared)
- 3 Drain hose
- 4 Rear panel
- 5 Rear panel fixing holes (Ø5.3 holes or as shown in figure "C")
- 6 Tubing and wiring holes (Ø80)

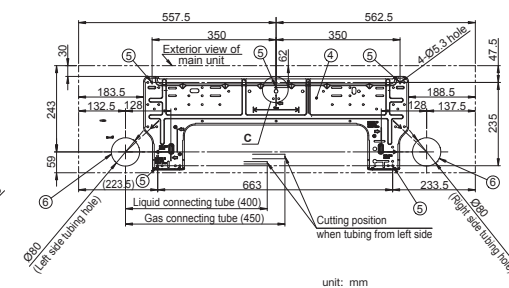

unit: mm

NEW
U2 TYPE 4-Way Cassette
Semi concealed cassette



Provides a neat fit in the ceiling to match modern décor, and uniform cooling throughout the room, and easy installation.



- AIR INTAKE CHAMBER**
- 1 [1] Air intake flange (ø100) (field supply)
 - 2 Air intake box CZ-ATU2*(ø100)
 - 3 Air intake plenum CZ-FDU3
- * When using Air intake box (CZ-ATU2), Air intake plenum (CZ-FDU3) is required.

NEW PANEL DESIGN
Flat design, well-matched with interior, building.



Optional accessory



Technical focus

- New high performance turbo fan, new path system for heat exchanger
- Lower noise in slow fan operation
- Industry top light weight, easy piping
- Easy installation structure of the panel
- Econavi : Floor temperature and human sensor added. Activity amount detection and new circulator
- nanoe™ X : 20x for CAC (20 times more nanoe™ particle for wide commercial space). Inside cleaning by 20x nanoe™ + dry control

Flat Horizontal Design

The horizontal design of 4-way cassette achieves an elegant designed panel. Its slim design allow to protrude 33.5mm from the ceiling.



Drain pump of up to 850 mm from the ceiling surface

Built in drain pump allows flexible install and design options with up to 850mm lift. Long horizontal piping is also possible.

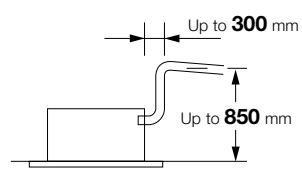

Easy to clean suction grille

Suction grille is able to make 90-degree turns.

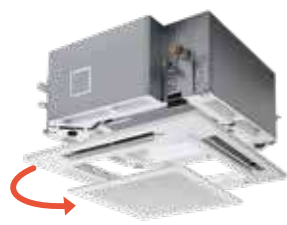

360° Wide & Comfortable Airflow

Comfort air flow control and proper energy use. Flexible Air Flow direction control by individual flap control:
-4 Flaps can be controlled individually (by standard wired remote controller*)
-Versatile air flow control to cover a wide variety of demands.

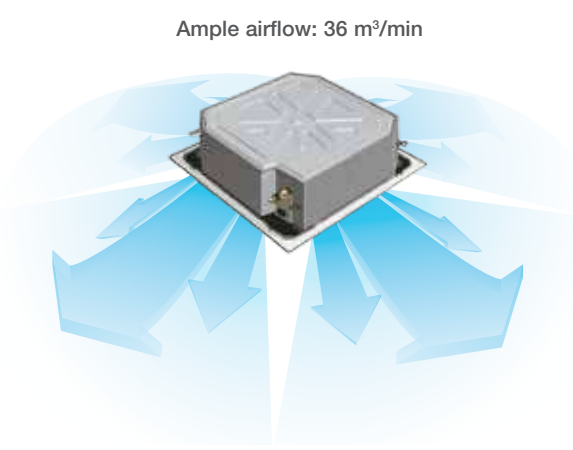
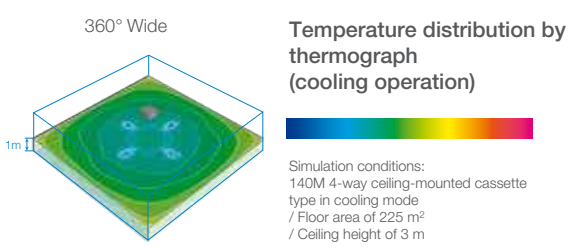

*Pre-setting is required for this function at System Test-run procedure

High-ceiling installation (Up to 5 m for 10.6 kW and higher capacity models)

The units can be installed in rooms with high ceilings, where they provide ample floor-level heating in the winter. (See ceiling height guidelines below.)

High Ceiling (Factory settings)

| | | | |
|-----------|-----------|-----------|-------------|
| New model | 2.7m | 3.0m | 3.6m |
| Capacity | 2.2-5.6kW | 6.0-9.0kW | 10.6-16.0kW |

| | | | |
|-------------|--|--|--|
| 10.6-16.0kW | 4.5m | 4.7m | 5m |
| Capacity | 4-way discharge high ceiling setting 2 | 3-way discharge with the optional air-blocking materials | 2-way discharge with the optional air-blocking materials |

Ceiling height guidelines

| Indoor unit | 4-way discharge | | | 3-way discharge (optional air-blocking materials) | 2-way discharge (optional air-blocking materials) *2 |
|-------------|-----------------|-------------------|------------------------|---|--|
| | *1 settings | Factory setting 1 | High ceiling setting 1 | | |
| 2.2-5.6kW | | 2.7 | 3.2 | 3.5 | 3.8 |
| 6.0-9.0kW | | 3.0 | 3.3 | 3.6 | 3.8 |
| 10.6-16.0kW | | 3.6 | 4.3 | 5.0 | 4.7 |

*1 When using the unit in a configuration other than the factory settings, it is necessary to make settings on site to increase airflow.
*2 Use air-blocking materials (CZ-CFU3) to completely block two discharge outlets for 2-way airflow.

Econavi panel is added into the line up

Continue Conventional function (Energy saving & comfort) and following are newly added.
• Energy saving function: comfortable energy saving based on temperature and humidity

- New circulate function that improves comfort
- Movement detection is improved improving comfort

Econavi energy saving function

Newly put humidity sensor on air suction part, and achieve more comfort and energy saving operation.
• Energy saving operation in case of low humidity during cooling operation

- Energy saving operation in case of high humidity during heating operation
- Energy saving operation based on activity amount and comfort and energy saving based on temperature and humidity.

Panels & Panel parts

Normal panel: CZ-KPU3H
Econavi panel: CZ-KPU3A



nanoe X Generator Mark 2

nanoe™ X contains plenty of OH radicals that have outstanding effects on various air pollutants, including bacteria and viruses, mould, allergens, pollen, hazardous substances, as well as deodorise odours. It also keeps moisture in your skin and hair.



Invisible Air Contaminants are Suppressed

U2_{TYPE} 4-Way Cassette

| Model Name | | S-22MU2E5B | S-28MU2E5B | S-36MU2E5B | S-45MU2E5B | S-56MU2E5B | |
|------------------------------|-----------------------|-----------------------------------|-------------------|-------------------|-------------------|-------------------|-------------|
| Power source | | 220/230/240 V, 1 phase - 50/60 Hz | | | | | |
| Cooling capacity | kW | 2.2 | 2.8 | 3.6 | 4.5 | 5.6 | |
| | BTU/h | 7,500 | 9,600 | 12,300 | 15,400 | 19,100 | |
| Heating capacity | kW | 2.5 | 3.2 | 4.2 | 5.0 | 6.3 | |
| | BTU/h | 8,500 | 10,900 | 14,300 | 17,100 | 21,500 | |
| Power input | Cooling kW | 0.020/0.020/0.020 | 0.020/0.020/0.020 | 0.020/0.020/0.020 | 0.020/0.020/0.020 | 0.025/0.025/0.025 | |
| | Heating kW | 0.020/0.020/0.020 | 0.020/0.020/0.020 | 0.020/0.020/0.020 | 0.020/0.020/0.020 | 0.025/0.025/0.025 | |
| Running current | Cooling A | 0.21/0.21/0.20 | 0.21/0.21/0.20 | 0.21/0.21/0.20 | 0.21/0.21/0.20 | 0.24/0.23/0.22 | |
| | Heating A | 0.20/0.20/0.19 | 0.20/0.20/0.19 | 0.20/0.20/0.19 | 0.20/0.20/0.19 | 0.23/0.22/0.21 | |
| Fan | Type | Turbo fan | | | | | |
| | Air flow rate (H/M/L) | m ³ /h | 870/780/690 | 870/780/690 | 870/780/690 | 930/780/690 | 990/810/690 |
| | | L/s | 242/217/192 | 242/217/192 | 242/217/192 | 258/217/192 | 275/225/192 |
| | Motor output | kW | | | | | |
| Sound power level (H/M/L) | dB | 45/44/43 | 45/44/43 | 45/44/43 | 46/44/43 | 47/45/43 | |
| Sound pressure level (H/M/L) | dB(A) | 30/29/28 | 30/29/28 | 30/29/28 | 31/29/28 | 32/30/28 | |
| Dimensions | H x W x D | mm | | | | | |
| | Liquid | mm (inches) | | | | | |
| | Gas | mm (inches) | | | | | |
| Pipe connections | Drain piping | VP-25 | | | | | |
| | Net weight (Panel) | kg | | | | | |

| GLOBAL REMARKS | Rated conditions: | |
|-------------------------|------------------------|-------------------|
| | Cooling | Heating |
| | Indoor air temperature | 27°C DB / 19°C WB |
| Outdoor air temperature | 35°C DB / 24°C WB | 7°C DB / 6°C WB |

* The values in () for external dimensions and Net weight are the values for the optional ceiling panel.
In the case of nanoe X OFF Specifications are subject to change without notice.

| S-60MU2E5B | S-73MU2E5B | S-90MU2E5B | S-106MU2E5B | S-140MU2E5B | S-160MU2E5B |
|------------------------------------|-------------------|-------------------|-------------------|-------------------|-------------------|
| 220/230/240 V, 1 phase - 50/60 Hz | | | | | |
| 6.0 | 7.3 | 9.0 | 10.6 | 14.0 | 16.0 |
| 20,500 | 24,900 | 30,700 | 36,200 | 47,800 | 54,600 |
| 7.1 | 8.0 | 10.0 | 11.4 | 16.0 | 18.0 |
| 24,200 | 27,300 | 34,100 | 38,900 | 54,600 | 61,400 |
| 0.035/0.035/0.035 | 0.040/0.040/0.040 | 0.040/0.040/0.040 | 0.090/0.090/0.090 | 0.095/0.095/0.095 | 0.105/0.105/0.105 |
| 0.035/0.035/0.035 | 0.040/0.040/0.040 | 0.040/0.040/0.040 | 0.085/0.085/0.085 | 0.090/0.090/0.090 | 0.100/0.100/0.100 |
| 0.34/0.33/0.32 | 0.37/0.36/0.35 | 0.39/0.38/0.37 | 0.74/0.71/0.68 | 0.77/0.74/0.71 | 0.85/0.82/0.79 |
| 0.33/0.32/0.31 | 0.36/0.35/0.34 | 0.38/0.37/0.36 | 0.72/0.69/0.66 | 0.75/0.72/0.69 | 0.83/0.80/0.77 |
| Turbo fan | Turbo fan | Turbo fan | Turbo fan | Turbo fan | Turbo fan |
| 1,260/960/780 | 1,350/960/780 | 1,380/1,110/840 | 2,040/1,500/1,140 | 2,160/1,560/1,200 | 2,220/1,680/1,440 |
| 350/267/217 | 375/267/217 | 383/308/233 | 567/417/317 | 600/433/333 | 617/467/400 |
| 0.06 | 0.06 | 0.06 | 0.09 | 0.09 | 0.09 |
| 51/47/44 | 52/47/44 | 53/50/47 | 59/53/49 | 60/54/50 | 61/55/53 |
| 36/32/29 | 37/32/29 | 38/35/32 | 44/38/34 | 45/39/35 | 46/40/38 |
| 319+(33.5) x 840 (950) x 840 (950) | | | | | |
| Ø9.52 (Ø3/8) | Ø9.52 (Ø3/8) | Ø9.52 (Ø3/8) | Ø9.52 (Ø3/8) | Ø9.52 (Ø3/8) | Ø9.52 (Ø3/8) |
| Ø15.88 (Ø5/8) | Ø15.88 (Ø5/8) | Ø15.88 (Ø5/8) | Ø15.88 (Ø5/8) | Ø15.88 (Ø5/8) | Ø15.88 (Ø5/8) |
| VP-25 | VP-25 | VP-25 | VP-25 | VP-25 | VP-25 |
| 20 (+5) | 20 (+5) | 20 (+5) | 25 (+5) | 25 (+5) | 25 (+5) |

Standard Equipped nanoe™ Technology

- nanoe™ X, charged water particles, contain hydroxyl radical (OH radical) that work to provide quality air.
- The electrodes of nanoe™ X devices are made of titanium and electricity discharge into the water particles of nanoe™. So no need to clean or replace the device (maintenance free without wear).



nanoe™ X module
Unique nanoe™ X module casing releases 9.6 trillion hydroxyl radical [OH radical] per second.



Made in JAPAN
Craftsmanship in Japan enables the adoption of titanium

Electrodes of nanoe™ X devices are produced with the support of craftsmen in Japan that has advanced expertise on processing ultra-small parts of titanium glass frames although titanium is very strong material and difficult to process.

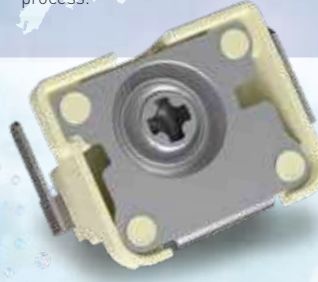

nanoe™ X device

U2 TYPE 4-WAY CASSETTE Dimensions

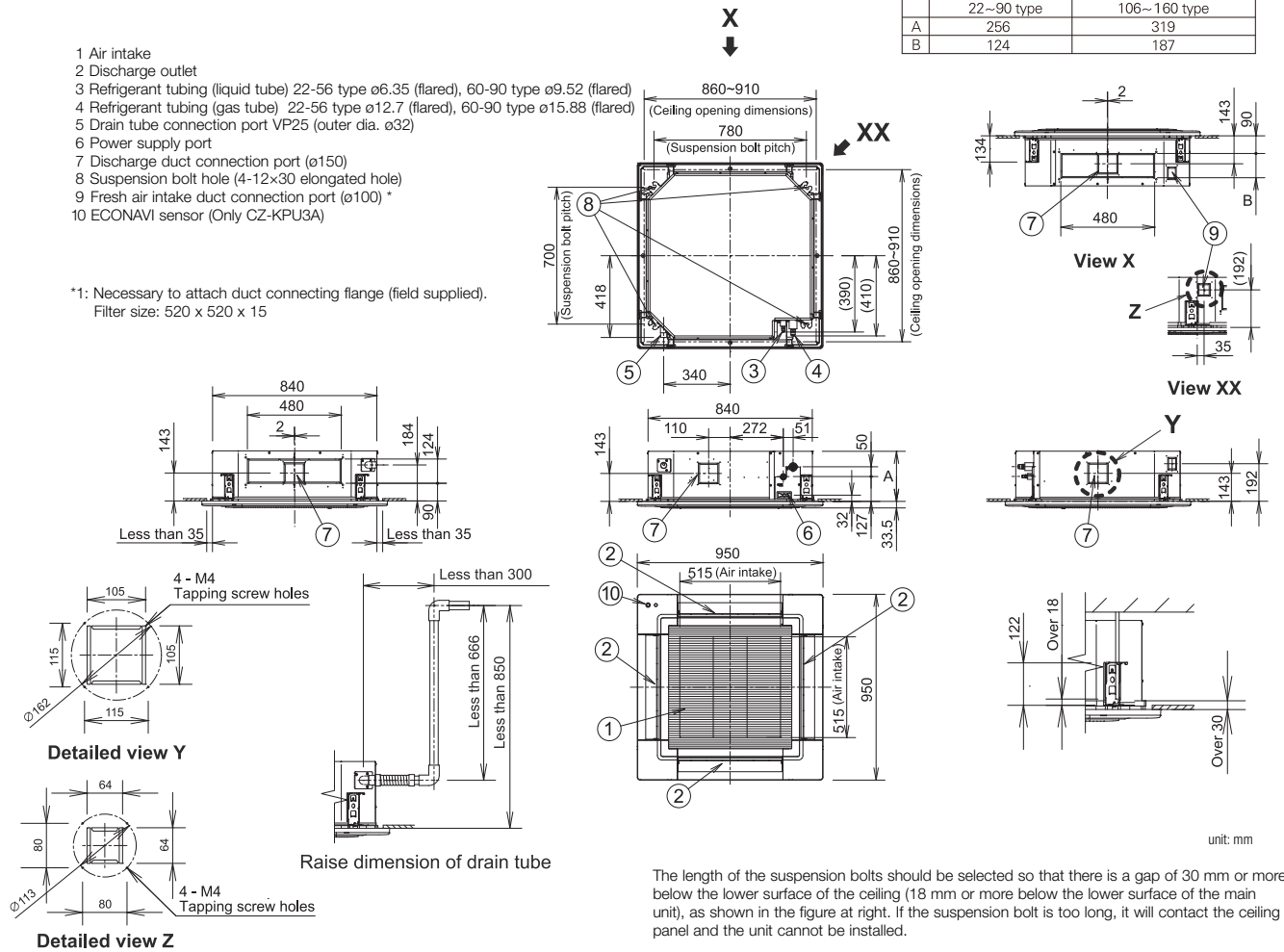

Y2 TYPE 4-Way Mini Cassette

Mini semi concealed cassette



Designed to fit perfectly into a 60 x 60 cm ceiling grid without the need to alter the bar configuration, the Y2 is ideal for small commercial and retrofit applications. In addition, improvements to the Y2's efficiency make this model one of the most advanced units in the industry.



Optional accessory



* Receiver is included in the 4-way mini cassette indoor unit.



Technical focus

- Mini cassette fits into a 60 x 60 cm ceiling grid
- Powerful drain pump gives 750 mm lift
- DC fan motor with variable speed and a new heat exchanger ensures efficient power consumption
- Fresh air knock out
- Multi directional air flow

Compact design

The panel is a compact (70x70 cm) so it can be installed even in a small room where space is limited.

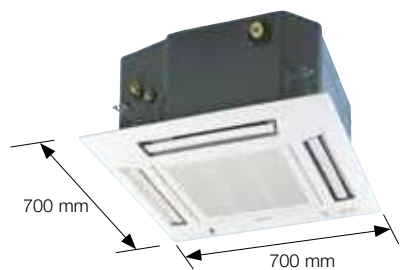

Lighter and slimmer, easier installation

When only 260mm of indoor body height, it can easily fit in limited spaces and tight spots. (Required 288mm from bottom of panel to top of the unit)

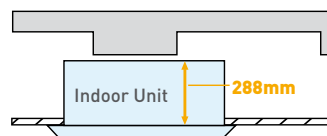

A drain height of up to 750 mm from the ceiling surface

The internal pump allows the drain pipe to be elevated up to 750mm above the base of the unit.

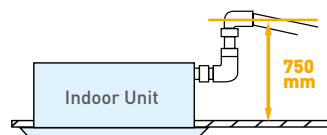

| Model Name | | S-22MY2E5A | S-28MY2E5A | S-36MY2E5A | S-45MY2E5A | S-56MY2E5A | |
|------------------------------|----------------------|-----------------------------------|--------------|--------------|--------------|--------------|-------------|
| Power source | | 220/230/240 V, 1 phase - 50/60 Hz | | | | | |
| Cooling capacity | kW | 2.2 | 2.8 | 3.6 | 4.5 | 5.6 | |
| | BTU/h | 7,500 | 9,600 | 12,300 | 15,400 | 19,100 | |
| Heating capacity | kW | 2.5 | 3.2 | 4.2 | 5.0 | 6.3 | |
| | BTU/h | 8,500 | 10,900 | 14,300 | 17,100 | 21,500 | |
| Power input | Cooling kW | 0.035 | 0.035 | 0.040 | 0.040 | 0.045 | |
| | Heating kW | 0.030 | 0.030 | 0.035 | 0.035 | 0.040 | |
| Running amperes | Cooling A | 0.30 | 0.30 | 0.30 | 0.32 | 0.35 | |
| | Heating A | 0.25 | 0.30 | 0.30 | 0.30 | 0.35 | |
| Fan motor | Type | Turbo fan | | | | | |
| | Airflow rate (H/M/L) | m³/h | 546/492/336 | 558/504/336 | 582/522/360 | 600/558/492 | 624/588/510 |
| | | L/s | 152/137/93 | 155/140/93 | 162/145/100 | 167/155/137 | 173/163/142 |
| | Output kW | 0.04 | 0.04 | 0.04 | 0.04 | 0.04 | |
| Power sound level (H/M/L) | dB | 50/46/40 | 50/46/40 | 51/47/41 | 53/49/43 | 55/52/49 | |
| Sound pressure level (H/M/L) | dB(A) | 35/31/25 | 35/31/25 | 36/32/26 | 38/34/28 | 40/37/34 | |
| Dimensions* H x W x D | mm | 288 (+31) x 575 (700) x 575 (700) | | | | | |
| | Liquid mm (inches) | Ø6.35 (Ø1/4) | Ø6.35 (Ø1/4) | Ø6.35 (Ø1/4) | Ø6.35 (Ø1/4) | Ø6.35 (Ø1/4) | |
| Pipe connections | Gas mm (inches) | Ø12.7 (Ø1/2) | Ø12.7 (Ø1/2) | Ø12.7 (Ø1/2) | Ø12.7 (Ø1/2) | Ø12.7 (Ø1/2) | |
| | Drain piping | VP-25 | VP-25 | VP-25 | VP-25 | VP-25 | |
| Net weight* | kg | 18 (+2.4) | 18 (+2.4) | 18 (+2.4) | 18 (+2.4) | 18 (+2.4) | |

| GLOBAL REMARKS | Rated conditions: | |
|----------------|---|-----------------|
| | Cooling | Heating |
| | Indoor air temperature 27°C DB / 19°C WB | 20°C DB |
| | Outdoor air temperature 35°C DB / 24°C WB | 7°C DB / 6°C WB |

* The values in () for external dimensions and Net weight are the values for the optional ceiling panel. Specifications are subject to change without notice.

Y2 TYPE 4-WAY CASSETTE Dimensions

- 1 Air intake grill
- 2 Air outlet
- 3 Refrigerant piping (liquid pipe) ø6.35 (flared)
- 4 Refrigerant piping (gas pipe) ø12.7 (flared)
- 5 Drain tube connection port VP25 (outer ø32)
- 6 Power supply entry
- 7 Suspension bolt hole (4-11 x 26 slot)
- 8 Fresh air intake duct connection port (ø80)

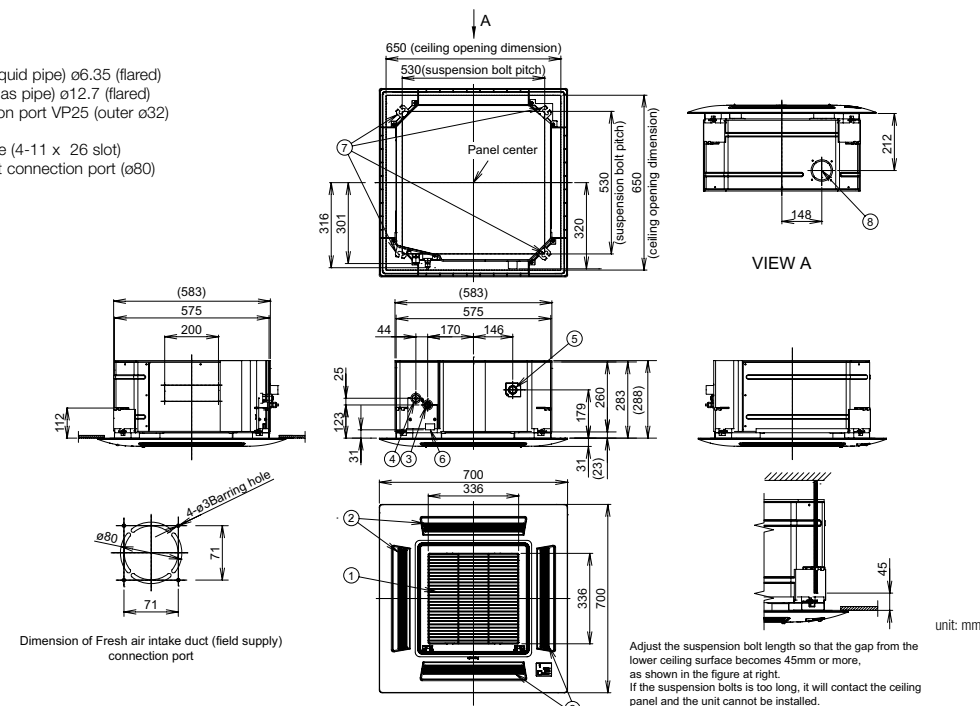

L1 TYPE 2-Way Cassette

The L1 is very thin, compact and light, allowing flexible install options. A redesigned fan has been used to achieve this size and weight reduction.

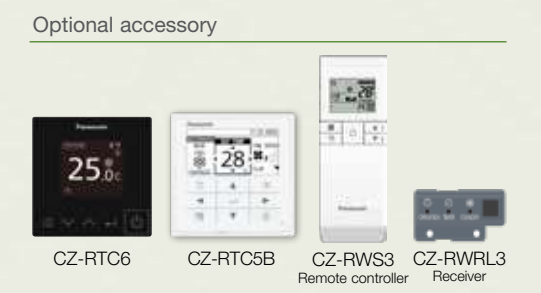

Technical focus

- Airflow and distribution is automatically altered depending on the operational mode of the unit
- Drain up is possible up to 500 mm via the built-in drain pump
- Simple maintenance

Auto flap control

Airflow and distribution is automatically altered depending on the operational mode (cooling or heating) of the unit.

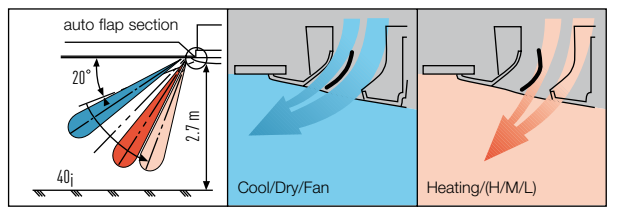

Drain up is possible up to 500 mm via the built-in drain pump.

Maintenance of the drain pump is possible from both sides, from the left side (piping side) and from the inside of the unit.

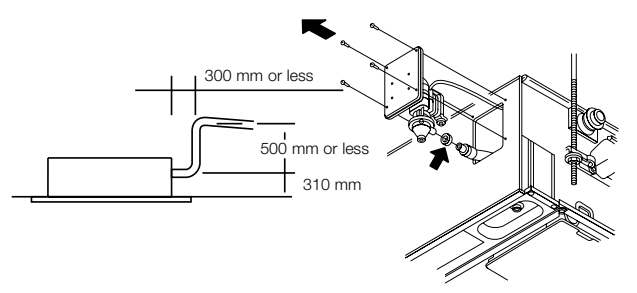

Simple maintenance

The drain pan is equipped with site wiring and can be removed. The fan case has a split construction, and the fan motor can be removed easily when the lower case is removed.

| Model Name | | S-22ML1E5 | S-28ML1E5 | S-36ML1E5 | S-45ML1E5 | S-56ML1E5 | S-73ML1E5 |
|------------------------------|-----------------------|-----------------------------------|------------------------------|------------------------------|------------------------------|------------------------------|---------------------------------|
| Power source | | 220/230/240 V, 1 phase - 50/60 Hz | | | | | |
| Cooling capacity | kW | 2.2 | 2.8 | 3.6 | 4.5 | 5.6 | 7.3 |
| | BTU/h | 7,500 | 9,600 | 12,000 | 15,000 | 19,000 | 25,000 |
| Heating capacity | kW | 2.5 | 3.2 | 4.2 | 5.0 | 6.3 | 8.0 |
| | BTU/h | 8,500 | 11,000 | 14,000 | 17,000 | 21,000 | 27,000 |
| Power input | Cooling kW | 0.086/0.090/0.095 | 0.086/0.092/0.097 | 0.088/0.093/0.099 | 0.091/0.097/0.103 | 0.091/0.097/0.103 | 0.135/0.145/0.154 |
| | Heating kW | 0.055/0.058/0.062 | 0.055/0.060/0.064 | 0.057/0.061/0.066 | 0.060/0.065/0.070 | 0.060/0.065/0.070 | 0.100/0.109/0.117 |
| Running current | Cooling A | 0.45/0.45/0.45 | 0.44/0.45/0.45 | 0.44/0.45/0.45 | 0.45/0.45/0.45 | 0.45/0.45/0.45 | 0.64/0.65/0.66 |
| | Heating A | 0.29/0.29/0.30 | 0.28/0.29/0.30 | 0.28/0.29/0.30 | 0.29/0.29/0.30 | 0.29/0.29/0.30 | 0.46/0.48/0.49 |
| Fan | Type | Sirocco fan | Sirocco fan | Sirocco fan | Sirocco fan | Sirocco fan | Sirocco fan |
| | Air flow rate (H/M/L) | 480/420/360 | 540/480/420 | 580/520/460 | 660/540/480 | 660/540/480 | 1,140/960/840 |
| | L/s | 133/117/100 | 150/133/117 | 161/144/128 | 183/150/133 | 183/150/133 | 317/267/233 |
| | Motor output kW | 0.03 | 0.03 | 0.03 | 0.03 | 0.03 | 0.05 |
| Sound power level (H/M/L) | dB | 40/38/35 | 44/40/37 | 45/42/39 | 46/44/40 | 46/44/40 | 49/46/44 |
| Sound pressure level (H/M/L) | dB(A) | 30/27/24 | 33/29/26 | 34/31/28 | 35/33/29 | 35/33/29 | 38/35/33 |
| Dimensions * H x W x D | mm | 350+80x840 (1,060)x600 (680) | 350+80x840 (1,060)x600 (680) | 350+80x840 (1,060)x600 (680) | 350+80x840 (1,060)x600 (680) | 350+80x840 (1,060)x600 (680) | 350+80x 1,140 (1,360)x600 (680) |
| | Liquid mm (inches) | Ø6.35 (Ø1/4) | Ø6.35 (Ø1/4) | Ø6.35 (Ø1/4) | Ø6.35 (Ø1/4) | Ø6.35 (Ø1/4) | Ø9.52 (Ø3/8) |
| Pipe connections | Gas mm (inches) | Ø12.7 (Ø1/2) | Ø12.7 (Ø1/2) | Ø12.7 (Ø1/2) | Ø12.7 (Ø1/2) | Ø12.7 (Ø1/2) | Ø15.88 (Ø5/8) |
| | Drain piping | VP-25 | VP-25 | VP-25 | VP-25 | VP-25 | VP-25 |
| Net weight * | kg | 23 (+5.5) | 23 (+5.5) | 23 (+5.5) | 23 (+5.5) | 23 (+5.5) | 30 (+9) |

| GLOBAL REMARKS | Rated conditions: | | |
|-------------------------|------------------------|-------------------|---------|
| | Cooling | Heating | |
| | Indoor air temperature | 27°C DB / 19°C WB | 20°C DB |
| Outdoor air temperature | 35°C DB / 24°C WB | 7°C DB / 6°C WB | |

* The values in () for external dimensions and Net weight are the values for the optional ceiling panel. Specifications are subject to change without notice.

L1 TYPE 2-WAY CASSETTE Dimensions

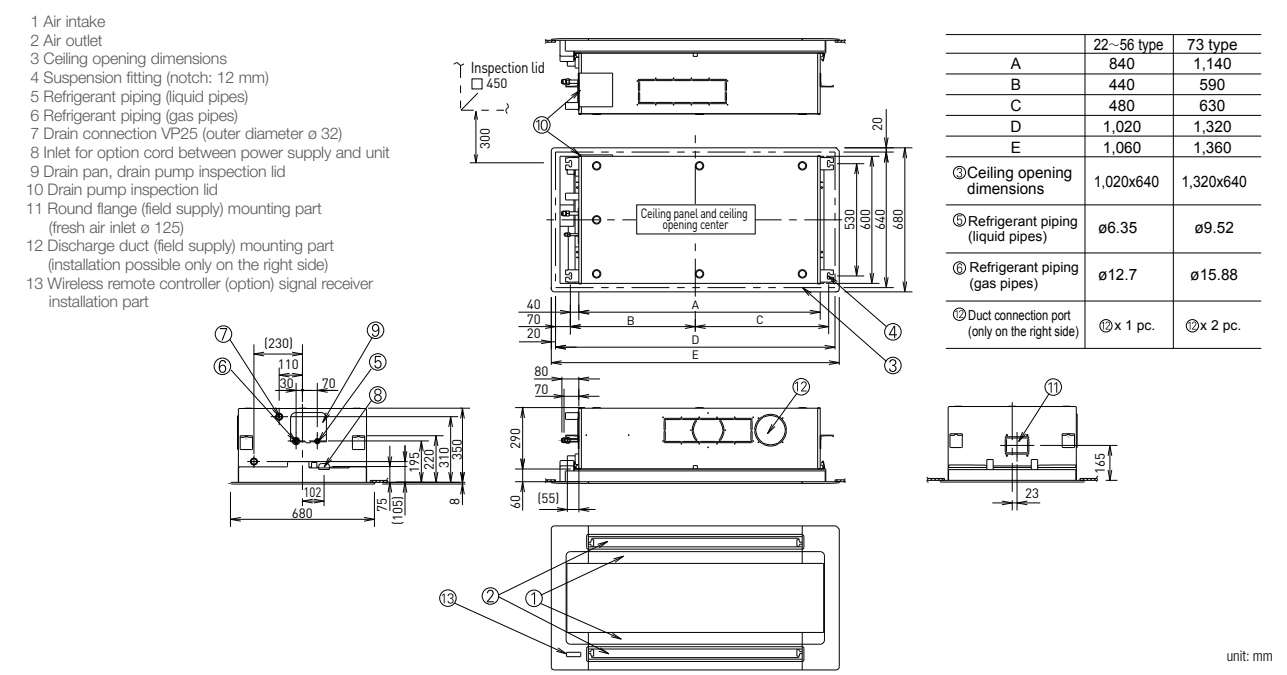

D1 TYPE 1-Way Cassette

Semi concealed slim cassette



Designed for installation within the ceiling void, the D1 range of slimline 1 way cassettes feature a quiet yet powerful fan that can reach the floor up 4.2 m from ceiling height.



Technical focus

- Ultra-Slim profile
- Suitable for standard and high ceilings
- Built-in drain pump provides 590 mm lift from ceiling
- Easy to install and maintain
- Hanging height can be easily adjusted
- Uses a DC fan motor to improve energy-efficiency

Drain height

A built-in drain pump provides up to 590mm lift from ceiling height for flexible install options.

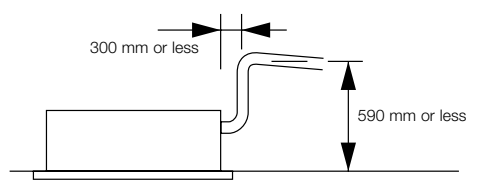

With 3 types of air-blow systems, the units can be used in various ways.



(1) One-direction "down-blow" system

Powerful one-direction "down-blow" system reaches the floor even from high ceilings (up to 4.2 m).



(2) Two-direction ceiling-mounted system

"Down-blow" and "front-blow" systems are combined in a ceiling-mounted unit to blow air over a wide area.



(3) One-direction ceiling-mounted system

This powerful ceiling-mounted "front-blow" system efficiently air-conditions the space in front of the unit. (Additional accessories required)

| Model Name | | S-28MD1E5 | S-36MD1E5 | S-45MD1E5 | S-56MD1E5 | S-73MD1E5 |
|------------------------------------|--------------------------------------|-----------------------------------|-------------------|-------------------|-------------------|-------------------|
| Power source | | 220/230/240 V, 1 phase - 50/60 Hz | | | | |
| Cooling capacity | kW | 2.8 | 3.6 | 4.5 | 5.6 | 7.3 |
| | BTU/h | 9,600 | 12,000 | 15,000 | 19,000 | 25,000 |
| Heating capacity | kW | 3.2 | 4.2 | 5.0 | 6.3 | 8.0 |
| | BTU/h | 11,000 | 14,000 | 17,000 | 21,000 | 27,000 |
| Power input | Cooling kW | 0.050/0.051/0.052 | 0.050/0.051/0.052 | 0.050/0.051/0.052 | 0.058/0.060/0.061 | 0.086/0.087/0.089 |
| | Heating kW | 0.039/0.040/0.042 | 0.039/0.040/0.042 | 0.039/0.040/0.042 | 0.046/0.048/0.049 | 0.075/0.076/0.077 |
| Running current | Cooling A | 0.40/0.39/0.39 | 0.40/0.39/0.39 | 0.40/0.39/0.39 | 0.46/0.46/0.46 | 0.71/0.70/0.69 |
| | Heating A | 0.36/0.35/0.35 | 0.36/0.35/0.35 | 0.36/0.35/0.35 | 0.42/0.41/0.41 | 0.66/0.65/0.63 |
| Fan | Type | Sirocco fan | | | | |
| | Air flow rate (H/M/L) m³/h | 720/600/540 | 720/600/540 | 720/660/600 | 780/690/600 | 1,080/900/780 |
| | L/s | 200/167/150 | 200/167/150 | 200/183/167 | 217/192/167 | 300/250/217 |
| | Motor output kW | 0.05 | | | | |
| Sound power level (H/M/L) dB | 47/45/44 | | | | | |
| Sound pressure level (H/M/L) dB(A) | 36/34/33 | | | | | |
| Dimensions * H x W x D mm | 200+(20) x 1,000 (1,230) x 710 (800) | | | | | |
| | Liquid mm (inches) | Ø6.35 (Ø1/4) | Ø6.35 (Ø1/4) | Ø6.35 (Ø1/4) | Ø6.35 (Ø1/4) | Ø9.52 (Ø3/8) |
| Pipe connections | Gas mm (inches) | Ø12.7 (Ø1/2) | Ø12.7 (Ø1/2) | Ø12.7 (Ø1/2) | Ø12.7 (Ø1/2) | Ø15.88 (Ø5/8) |
| | Drain piping | VP-25 | | | | |
| Net weight * kg | 21 (+5.5) | | | | | |

* The values in () for external dimensions and Net weight are the values for the optional ceiling panel. Specifications are subject to change without notice.

D1 TYPE 1-WAY CASSETTE Dimensions

- 1 Air intake grille
- 2 Air outlet
- 3 Refrigerant piping (liquid pipes)
Size 28 to 56: Ø6.35 (flared)
Size 73: Ø9.52 (flared)
- 4 Refrigerant piping (gas pipes)
Size 28 to 56: Ø12.7 (flared)
Size 73: Ø15.88 (flared)
- 5 Drain connection VP25 (outer Ø32)
- 6 Power supply entry
- 7 Discharge duct connection port (for descending ceiling)
- 8 Wireless remote control receiver (option)
- 9 Suspension mounting (4-12 x 30 slot)
- 10 Fresh air intake (Ø100)

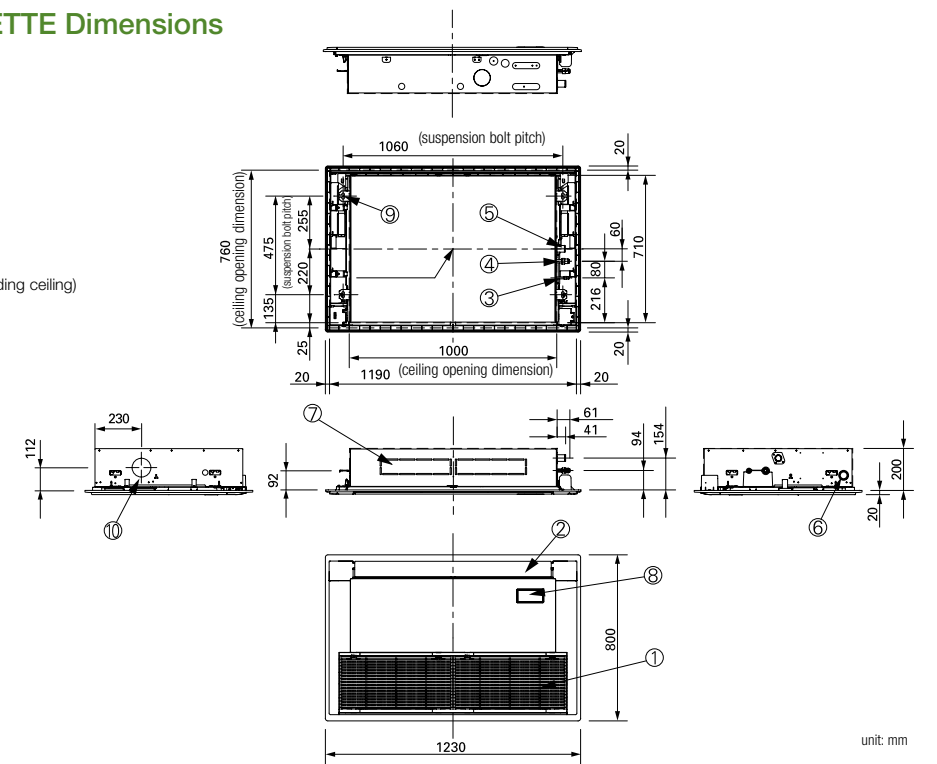

unit: mm

T2 TYPE Ceiling Mounted

Ceiling mounted



Providing outstanding energy-saving performance and comfortable, long-distance air flow distribution, it's recommended for stores and schools.



S-36MT2E5A / S-45MT2E5A
S-56MT2E5A



S-73MT2E5A



S-106MT2E5A
S-140MT2E5A

Optional accessory



- Self-diagnosing Function
- Automatic Fan Operation
- Dry mode
- Intelligent Auto Swing
- Automatic Restart Function
- Auto Swing (Auto Flap Control)

Technical focus

- Lower sound levels
- Standardised height and depth for all models
- Long and wide air distribution
- Easy to install and maintain
- Fresh air knockout

Compact Looking, Stylish, One-Motion Design

With its streamlined, one-motion form, the unit looks slim and compact when installed for a neat appearance in any room. When not operating, the louver closes to provide an elegant look while keeping the unit clean.



Energy-Saving Technology Delivering Top-Class Efficiency

Optimization of the shape of the casing and fan assures bigger air flow and higher efficiency. Energy-saving performance is top class in the industry.

Top Class Energy Saving

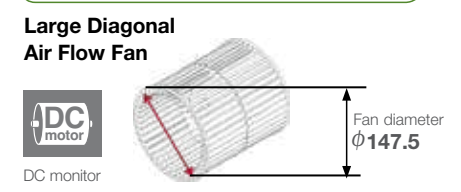

Comfortable, Long-Distance Air Flow Distribution

The shape of the outlet has been optimized to provide long-distance air flow distribution. Even in deep spaces, air flow reaches every corner for exceptionally comfortable air conditioning.

| High Ceiling Setting <small>*Setting by remote control</small> | Air flow distance | | |
|---|-------------------|-----|-----|
| | 112 | 140 | 160 |
| 4.3m | 12m | 13m | 13m |

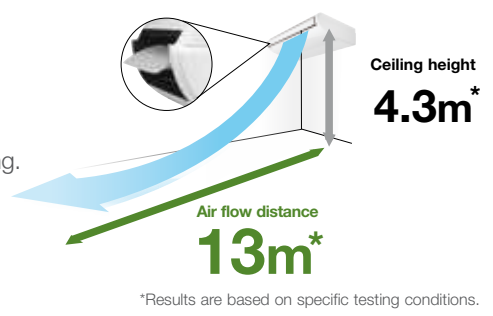

Multiple Piping Directions For Flexible Installation

The 5-directional drain pipe and 3-directional refrigerant pipe make installation much easier. And the neat fit with walls and ceilings assures more installation flexibility.

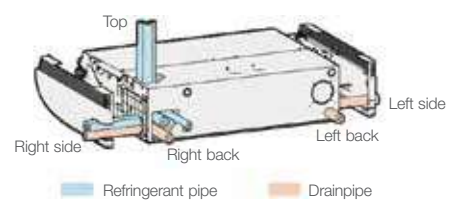

| Model Name | | S-36MT2E5A | S-45MT2E5A | S-56MT2E5A | S-73MT2E5A | S-106MT2E5A | S-140MT2E5A |
|------------------------------------|---|-----------------------------------|----------------------------|----------------------------|-----------------------------|-----------------------------|-----------------------------|
| Power source | | 220/230/240 V, 1 phase - 50/60 Hz | | | | | |
| Cooling capacity | kW | 3.6 | 4.5 | 5.6 | 7.3 | 10.6 | 14.0 |
| | BTU/h | 12,300 | 15,400 | 19,100 | 24,900 | 36,200 | 47,800 |
| Heating capacity | kW | 4.2 | 5.0 | 6.3 | 8.0 | 11.4 | 16.0 |
| | BTU/h | 14,300 | 17,100 | 21,500 | 27,300 | 38,900 | 54,600 |
| Power input | Cooling kW | 0.035/0.035/0.035 | 0.040/0.040/0.040 | 0.040/0.040/0.040 | 0.055/0.055/0.055 | 0.080/0.080/0.080 | 0.100/0.100/0.100 |
| | Heating kW | 0.035/0.035/0.035 | 0.040/0.040/0.040 | 0.040/0.040/0.040 | 0.055/0.055/0.055 | 0.080/0.080/0.080 | 0.100/0.100/0.100 |
| Running current | Cooling A | 0.37/0.36/0.35 | 0.39/0.38/0.37 | 0.39/0.38/0.37 | 0.45/0.44/0.43 | 0.69/0.67/0.65 | 0.82/0.79/0.77 |
| | Heating A | 0.37/0.36/0.35 | 0.39/0.38/0.37 | 0.39/0.38/0.37 | 0.45/0.44/0.43 | 0.69/0.67/0.65 | 0.82/0.79/0.77 |
| Fan | Type | Sirocco fan | Sirocco fan | Sirocco fan | Sirocco fan | Sirocco fan | Sirocco fan |
| | Air flow rate (H/M/L) m ³ /h | 840/720/630 | 900/750/630 | 900/750/630 | 1,260/1,080/930 | 1,800/1,500/1,380 | 1,920/1,680/1,440 |
| | L/s | 233/200/175 | 250/208/175 | 250/208/175 | 350/300/258 | 500/417/383 | 533/467/400 |
| | Motor output kW | 0.043 | 0.043 | 0.043 | 0.074 | 0.111 | 0.111 |
| Sound power level (H/M/L) dB | | 54/50/48 | 55/51/48 | 55/51/48 | 57/53/51 | 60/55/54 | 62/58/55 |
| Sound pressure level (H/M/L) dB(A) | | 36/32/30 | 37/33/30 | 37/33/30 | 39/35/33 | 42/37/36 | 44/40/37 |
| Dimensions | H x W x D mm | 235 x 960 x 690 | 235 x 960 x 690 | 235 x 960 x 690 | 235 x 1,275 x 690 | 235 x 1,590 x 690 | 235 x 1,590 x 690 |
| | Liquid mm (inches) | $\phi 6.35$ ($\phi 1/4$) | $\phi 6.35$ ($\phi 1/4$) | $\phi 6.35$ ($\phi 1/4$) | $\phi 9.52$ ($\phi 3/8$) | $\phi 9.52$ ($\phi 3/8$) | $\phi 9.52$ ($\phi 3/8$) |
| | Gas mm (inches) | $\phi 12.7$ ($\phi 1/2$) | $\phi 12.7$ ($\phi 1/2$) | $\phi 12.7$ ($\phi 1/2$) | $\phi 15.88$ ($\phi 5/8$) | $\phi 15.88$ ($\phi 5/8$) | $\phi 15.88$ ($\phi 5/8$) |
| Pipe connections | Drain piping | VP-20 | VP-20 | VP-20 | VP-20 | VP-20 | VP-20 |
| | | | | | | | |
| Net weight kg | | 27 | 27 | 27 | 33 | 40 | 40 |

| GLOBAL REMARKS | Rated conditions: | | |
|-------------------------|------------------------|-------------------|---------|
| | Cooling | Heating | |
| | Indoor air temperature | 27°C DB / 19°C WB | 20°C DB |
| Outdoor air temperature | 35°C DB / 24°C WB | 7°C DB / 6°C WB | |

Specifications are subject to change without notice.

T2 TYPE CEILING Dimensions

SIZE 36-56

- 1 Drain port VP20 (inside diameter $\phi 26$ mm, drain hose supplied)
- 2 Left drain position
- 3 Refrigerant piping (liquid pipes)
Size 36 to 56: $\phi 6.35$ (flared)
Size 73 to 140: $\phi 9.52$ (flared)
- 4 Refrigerant piping (gas pipes)
Size 36 to 56: $\phi 12.7$ (flared)
Size 73 to 140: $\phi 15.88$ (flared)

SIZE 73-140

- 5 Left side drain hose outlet port (cutout)
- 6 Piping hole on wall surface $\phi 100$ mm
- 7 Upper side piping port
- 8 Right side drain hose outlet port (cutout)
- 9 Wireless remote controller receiver installation location

| | A | B | C | D | E |
|--------------|-------|-----|-----|-------|-------|
| 106-140 type | 1,590 | 235 | 690 | 1,584 | 1,541 |
| 73 type | 1,275 | 235 | 690 | 1,269 | 1,226 |

unit: mm

P1 TYPE Floor Standing

The compact floor standing P1 units are the ideal solution for providing perimeter air conditioning. A standard wired controller can be incorporated into the body of the unit.



Optional accessory

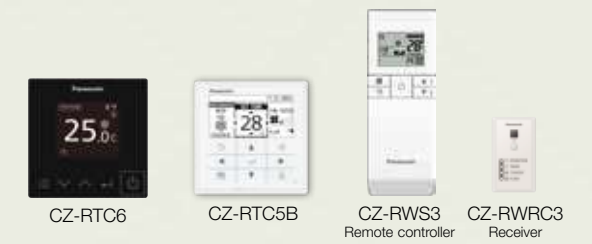

Technical focus

- Pipes can be connected to either side of the unit from the bottom or rear
- Easy to install
- Front panel opens fully for easy maintenance
- Removable air discharge grille gives flexible air flow

Effective perimeter air conditioning

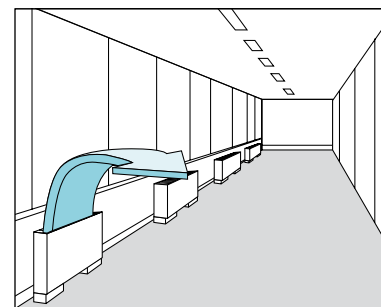

A wired remote control (CZ-RTC4/CZ-RTC5B) can be installed in the body

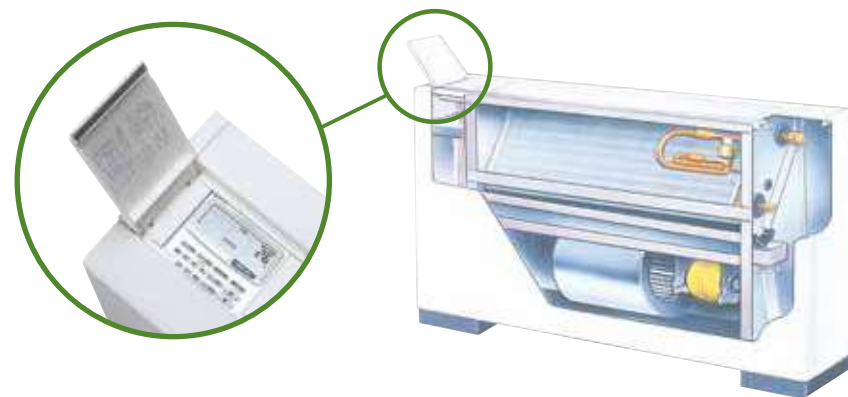

| Model Name | | S-22MP1E5 | S-28MP1E5 | S-36MP1E5 | S-45MP1E5 | S-56MP1E5 | S-71MP1E5 |
|------------------------------------|----------------------------|-----------------------------------|-------------------|-------------------|-------------------|-------------------|-------------------|
| Power source | | 220/230/240 V, 1 phase - 50/60 Hz | | | | | |
| Cooling capacity | kW | 2.2 | 2.8 | 3.6 | 4.5 | 5.6 | 7.1 |
| | BTU/h | 7,500 | 9,600 | 12,000 | 15,000 | 19,000 | 24,000 |
| Heating capacity | kW | 2.5 | 3.2 | 4.2 | 5.0 | 6.3 | 8.0 |
| | BTU/h | 8,500 | 11,000 | 14,000 | 17,000 | 21,000 | 27,000 |
| Power input | Cooling kW | 0.051/0.056/0.061 | 0.051/0.056/0.061 | 0.079/0.085/0.091 | 0.116/0.126/0.136 | 0.116/0.126/0.136 | 0.150/0.160/0.170 |
| | Heating kW | 0.036/0.040/0.045 | 0.036/0.040/0.045 | 0.064/0.070/0.076 | 0.079/0.091/0.101 | 0.079/0.091/0.101 | 0.110/0.120/0.130 |
| Running current | Cooling A | 0.24/0.25/0.26 | 0.24/0.25/0.26 | 0.37/0.38/0.39 | 0.54/0.56/0.58 | 0.54/0.56/0.58 | 0.70/0.72/0.73 |
| | Heating A | 0.17/0.18/0.19 | 0.17/0.18/0.19 | 0.30/0.31/0.32 | 0.37/0.41/0.43 | 0.37/0.41/0.43 | 0.52/0.54/0.56 |
| Fan | Type | Sirocco fan | Sirocco fan | Sirocco fan | Sirocco fan | Sirocco fan | Sirocco fan |
| | Air flow rate (H/M/L) m³/h | 420/360/300 | 420/360/300 | 540/420/360 | 720/540/480 | 900/780/660 | 1,020/840/720 |
| | L/s | 117/100/83 | 117/100/83 | 150/117/100 | 200/150/133 | 250/217/183 | 283/233/200 |
| | Motor output kW | 0.01 | 0.01 | 0.02 | 0.02 | 0.03 | 0.06 |
| Sound power level (H/M/L) dB | | 44/41/39 | 44/41/39 | 50/46/40 | 49/46/42 | 50/47/42 | 52/49/46 |
| Sound pressure level (H/M/L) dB(A) | | 33/30/28 | 33/30/28 | 39/35/29 | 38/35/31 | 39/36/31 | 41/38/35 |
| Dimensions | H x W x D mm | 615 x 1,065 x 230 | 615 x 1,065 x 230 | 615 x 1,065 x 230 | 615 x 1,380 x 230 | 615 x 1,380 x 230 | 615 x 1,380 x 230 |
| | Liquid mm (inches) | Ø6.35 (Ø1/4) | Ø6.35 (Ø1/4) | Ø6.35 (Ø1/4) | Ø6.35 (Ø1/4) | Ø6.35 (Ø1/4) | Ø9.52 (Ø3/8) |
| | Gas mm (inches) | Ø12.7 (Ø1/2) | Ø12.7 (Ø1/2) | Ø12.7 (Ø1/2) | Ø12.7 (Ø1/2) | Ø12.7 (Ø1/2) | Ø15.88 (Ø5/8) |
| Pipe connections | Drain piping | VP-20 | VP-20 | VP-20 | VP-20 | VP-20 | VP-20 |
| Net weight kg | | 29 | 29 | 29 | 39 | 39 | 39 |

| GLOBAL REMARKS | Rated conditions: | |
|---|--|---------|
| | Cooling | Heating |
| | Indoor air temperature 27°C DB / 19°C WB | 20°C DB |
| Outdoor air temperature 35°C DB / 24°C WB | 7°C DB / 6°C WB | |

Specifications are subject to change without notice.

P1 TYPE FLOOR STANDING Dimensions

- 1 4 x Ø12 holes (for floor fixing)
- 2 Power supply outlet
- 3 Air filter
- 4 Refrigerant piping (liquid pipes)
- 5 Refrigerant piping (gas pipes)
- 6 Level adjustment bolt
- 7 Drain outlet VP20 (with vinyl hose)
- 8 Refrigerant piping connection port (bottom or rear)
- 9 Operation switch (remote controller RCS-SH80AG) mounting part
- 10 Electric equipment box
- 11 Accessory copper pipe for gas pipe connection

| Indoor unit | A | B | C | Liquid pipes | Gas pipes |
|---------------|-------|-----|-----|--------------|-----------|
| 22 to 36 type | 1,065 | 665 | 632 | Ø6.35 | Ø12.7 |
| 45 type | | | | | |
| 56 type | 1,380 | 980 | 947 | Ø9.52 | Ø15.88 |
| 71 type | | | | | |

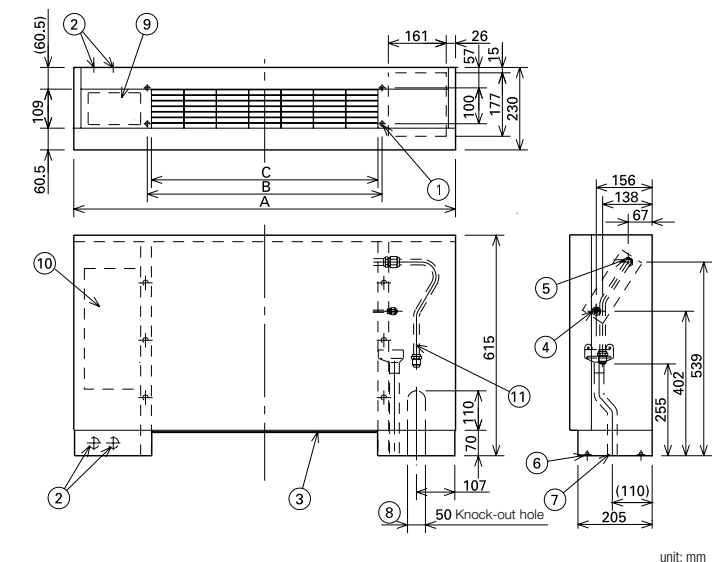

unit: mm

R1 TYPE Concealed Floor Standing

At just 229 mm deep, the R1 unit can be easily concealed in perimeter areas to provide powerful and effective air conditioning.



Optional accessory

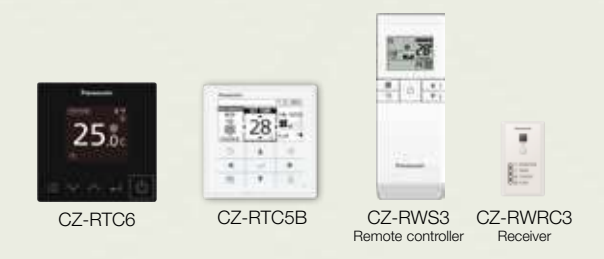

Technical focus

- Chassis unit for discrete customisable installation
- Complete with removable filters
- Pipes can be connected to the unit either from the bottom or rear
- Easy to install

Perimeter air conditioning with high interior quality

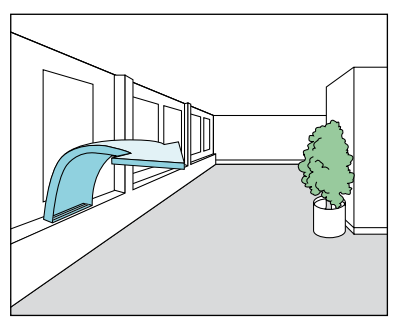

| Model Name | | S-22MR1E5 | S-28MR1E5 | S-36MR1E5 | S-45MR1E5 | S-56MR1E5 | S-71MR1E5 |
|------------------------------------|----------------------------|-----------------------------------|-------------------|-------------------|-------------------|-------------------|-------------------|
| Power source | | 220/230/240 V, 1 phase - 50/60 Hz | | | | | |
| Cooling capacity | kW | 2.2 | 2.8 | 3.6 | 4.5 | 5.6 | 7.1 |
| | BTU/h | 7,500 | 9,600 | 12,000 | 15,000 | 19,000 | 24,000 |
| Heating capacity | kW | 2.5 | 3.2 | 4.2 | 5.0 | 6.3 | 8.0 |
| | BTU/h | 8,500 | 11,000 | 14,000 | 17,000 | 21,000 | 27,000 |
| Power input | Cooling kW | 0.051/0.056/0.061 | 0.051/0.056/0.061 | 0.079/0.085/0.091 | 0.116/0.126/0.136 | 0.116/0.126/0.136 | 0.150/0.160/0.170 |
| | Heating kW | 0.036/0.040/0.045 | 0.036/0.040/0.045 | 0.064/0.070/0.076 | 0.079/0.091/0.101 | 0.079/0.091/0.101 | 0.110/0.120/0.130 |
| Running current | Cooling A | 0.24/0.25/0.26 | 0.24/0.25/0.26 | 0.37/0.38/0.39 | 0.54/0.56/0.58 | 0.54/0.56/0.58 | 0.70/0.72/0.73 |
| | Heating A | 0.17/0.18/0.19 | 0.17/0.18/0.19 | 0.30/0.31/0.32 | 0.37/0.41/0.43 | 0.37/0.41/0.43 | 0.52/0.54/0.56 |
| Fan | Type | Sirocco fan | Sirocco fan | Sirocco fan | Sirocco fan | Sirocco fan | Sirocco fan |
| | Air flow rate (H/M/L) m³/h | 420/360/300 | 420/360/300 | 540/420/360 | 720/540/480 | 900/780/660 | 1,020/840/720 |
| | L/s | 117/100/183 | 117/100/183 | 150/117/100 | 200/150/133 | 250/217/183 | 283/233/200 |
| | Motor output kW | 0.01 | 0.01 | 0.02 | 0.02 | 0.03 | 0.06 |
| Sound power level (H/M/L) dB | | 44/41/39 | 44/41/39 | 50/46/40 | 49/46/42 | 49/46/42 | 52/49/46 |
| Sound pressure level (H/M/L) dB(A) | | 33/30/28 | 33/30/28 | 39/35/29 | 38/35/31 | 39/36/31 | 41/38/35 |
| Dimensions H x W x D mm | | 616 x 904 x 229 | 616 x 904 x 229 | 616 x 904 x 229 | 616 x 1,219 x 229 | 616 x 1,219 x 229 | 616 x 1,219 x 229 |
| | Liquid mm (inches) | Ø6.35 (Ø1/4) | Ø6.35 (Ø1/4) | Ø6.35 (Ø1/4) | Ø6.35 (Ø1/4) | Ø6.35 (Ø1/4) | Ø9.52 (Ø3/8) |
| | Gas 410 A mm (inches) | Ø12.7 (Ø1/2) | Ø12.7 (Ø1/2) | Ø12.7 (Ø1/2) | Ø12.7 (Ø1/2) | Ø12.7 (Ø1/2) | Ø15.88 (Ø5/8) |
| Pipe connections | Drain piping | VP-20 | VP-20 | VP-20 | VP-20 | VP-20 | VP-20 |
| Net weight kg | | 21 | 21 | 21 | 28 | 28 | 28 |

| GLOBAL REMARKS | Rated conditions: | |
|---|--|---------|
| | Cooling | Heating |
| | Indoor air temperature 27°C DB / 19°C WB | 20°C DB |
| Outdoor air temperature 35°C DB / 24°C WB | 7°C DB / 6°C WB | |

Specifications are subject to change without notice.

R1 TYPE CONCEALED FLOOR STANDING Dimensions

- 1 4 x Ø12 holes (for floor fixing)
- 2 Electric equipment box
- 3 Power supply outlet
- 4 Air filter
- 5 Discharge duct connection flange
- 6 Refrigerant connection outlet (liquid pipes)
- 7 Refrigerant connection outlet (gas pipes)
- 8 Drain filter
- 9 Drain pan
- 10 Level adjustment bolt
- 11 Drain outlet VP20 (with vinyl hose)

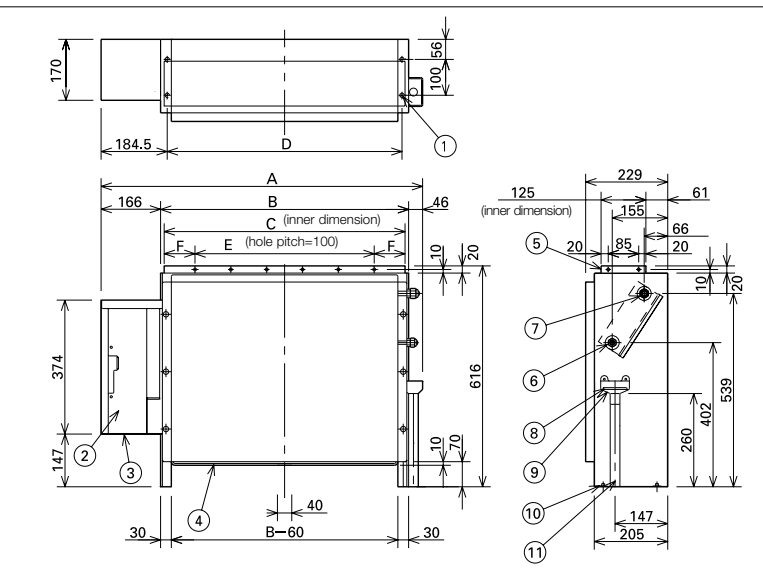

| Indoor unit | A | B | C | D | E | F | Liquid pipes | Gas pipes |
|---------------|-------|-------|-------|-----|-----|----|--------------|-----------|
| 22 to 36 type | 904 | 692 | 672 | 665 | 500 | 86 | Ø6.35 | Ø12.7 |
| 45 type | | | | | | | | |
| 56 type | 1,219 | 1,007 | 1,002 | 980 | 900 | 51 | Ø9.52 | Ø15.88 |
| 71 type | | | | | | | | |

unit: mm

Remark for High Static Ducted Series



E2 type
High Static Ducted



E2 type
Energy Saving High-Fresh Air Ducted





E1 type
High Static Ducted



H1 type
High-Fresh Air Ducted



| Model | Operation | Rap valve kit CZ-P160RVK2  | 3-way control PCB CZ-CAPE2  | Distribution Joint kit <2pipes> CZ-P160BK2 for 22.4kW unit or less CZ-P680BK2 for more than 22.4kW |
|--|--------------|--|--|---|
| E2 Type High Static Ducted | Cooling Only | - | - | - |
| | Cool or Heat | - | - | - |
| E2 Type Energy Saving High-Fresh Air Ducted | Cooling Only | - | - | - |
| | Cool or Heat | 2pcs | 2pcs | 2pcs |
| E1 Type High Static Ducted (Only for S-224,S-280) | Cooling Only | - | - | - |
| | Cool or Heat | 2pcs | - | 2pcs |
| H1 Type High-Fresh Air Ducted | Cooling Only | - | - | - |
| | Cool or Heat | 2pcs | - | 2pcs |



FSV Controllers

A wide variety of control options to meet the requirements of different applications.

ECONAVI ECONAVI Sensor CZ-CENSC1



Utilises ECONAVI Sensor and Control Program technologies to detect where energy is normally wasted and self-adjusts cooling power to reduce energy waste.

- Activity detection
- Absence detection

| Operation system | Individual control systems | | | |
|--|---|--|--|---|
| Requirements | Simplified operation | High-spec operation | Normal operation | Operation from anywhere in the room |
| External appearance | | | | |
| Type, model name | Simplified Wired Remote Controller CZ-RTC6 | High-spec Wired Remote Controller CZ-RTC5B | Timer Remote Controller (Wired) CZ-RTC4 | Wireless Remote Controller Controller: CZ-RWS3 Receiver: CZ-RWRU3 CZ-RWRL3 CZ-RWRD3 CZ-RWRT3 CZ-RWRC3 |
| Built-in thermostat | ● | ● | ● | — |
| nanoe™ X on/off control | ● | ● | — | ● |
| ECONAVI ON/OFF control | ● | ● | ● | ● |
| Number of indoor units which can be controlled | 1 group, 8 units | 1 group, 8 units | 1 group, 8 units | 1 group, 8 units |
| Use limitations | · CZ-RTC6 : Up to 2 controllers can be connected per group (only combination possible with CZ-RTC6) | · Up to 2 controllers can be connected per group (When using ECONAVI sensor, only one remote controller is possible to connect at indoor unit) | · Up to 2 controllers can be connected per group (When using ECONAVI sensor, only one remote controller is possible to connect at indoor unit) | · Up to 2 controllers can be connected per group. |
| Function ON/OFF | ● | ● | ● | ● |
| Mode setting | ● | ● | ● | ● |
| Fan speed setting | ● | ● | ● | ● |
| Temperature setting | ● | ● | ● | ● |
| Air flow direction | ● | ● | ● | ● |
| Permit/Prohibit switching | — | — | — | — |
| Weekly program | — | ● | ● | — |

All specifications are subject to change without notice.

| Timer operation | Centralised control systems | | | | BMS System PC Base | Connection with 3rd Party Controller |
|---|--|--|---|--|--------------------|--------------------------------------|
| Daily and weekly program | Operation with various functions from a central location | Only ON/OFF operation from a central location | Simplified load distribution ratio (LDR) for each tenant 10.4 in. touch screen panel color LCD | | | |
| Schedule Timer | | | | | | |
| CZ-ESWC2 | CZ-64ESMC3 | CZ-ANC3 | CZ-256ESMC3 (CZ-CFUNC2) | | | |
| 64 groups, max. 64 units | 64 groups, max. 64 units | 16 groups, max. 64 units | 64 units x 16 systems, max. 256 units | | | |
| · Required power supply from the system controller · When there is no system controller, connection is possible to the T10 terminal of an indoor unit. | · Up to 10 controllers, can be connected to one system. · Main unit/sub unit (1 main unit + 1 sub unit) connection is possible. · Use without remote controller is possible. | · Up to 8 controllers (4 main units + 4 sub units) can be connected to one system. · Use without remote controller is impossible. | · A communication adaptor (CZ-CFUNC2) must be installed for three or more links. | | | |
| — | ● | ● | ● | | | |
| — | ● | — | ● | | | |
| — | ● | — | ● | | | |
| — | ● | — | ● | | | |
| — | ● | — | ● | | | |
| — | ● | ● | ● | | | |
| ● | ● | — | ● | | | |

Simplified wired remote controller (CZ-RTC6)



Dimensions
H 86 x W 86 x D 25mm

Deluxe wired remote controller (CZ-RTC5B)



Dimensions
H 120 x W 120 x D 16 mm

| | CZ-RTC6 | CZ-RTC5B |
|--|---------|----------|
| Energy Saving | | |
| ECONAVI on/off | ● | ● |
| Temperature Auto Return | — | ● |
| Temperature Setting range | — | ● |
| Auto Shutoff | — | ● |
| Schedule peak cut | — | ● |
| Repeat off timer | — | ● |
| Basic Operation | | |
| Individual Louver Control(Lock individual flap for 4-WAY cassette) | — | ● |
| ON/OFF timer | — | ● |
| Weekly timer | — | ● |
| Filter information | ●* | ●* |
| Outing function | ● | ● |
| Quiet operation mode | — | ●* |
| Power consumption monitor | — | ●* |
| Energy saving | — | ●* |
| initial settings | — | ● |
| Ventilation | — | ● |
| nanoe™X | ●* | ●* |
| Maintenance Function | | |
| Outdoor unit error data | — | — |
| Service Contact address | — | — |
| RC setting mode | ● | ● |
| Test run | ● | ● |
| Sensor information | ●* | ●* |
| Service check | ● | ● |
| Simple/Detailed Settings | ● | ● |
| Auto address | ● | ● |
| Initial Settings | | |
| Rotation operation | — | ● |
| Backup operation | — | ● |
| Support operation | — | ● |

* Subject to the connected

Individual Control Systems

| Control contents | Part name, model No. | Quantity |
|---|---|-------------|
| Standard Control <ul style="list-style-type: none"> Control of the various operations of the indoor unit by wired or wireless remote controller. Cooling or heating mode of the outdoor unit is decided by the first priority of the remote controller. Switching between remote controller sensor and body sensor is possible. | Wired remote controller CZ-RTC4,CZ-RTC5B,CZ-RTC6 Wireless remote controller + Receiver CZ-RWS3 (Wall Mounted/ Mini Cassette) CZ-RWS3 + CZ-RWRL3 (4-WAY Cassette) CZ-RWS3 + CZ-RWRL3 (2-WAY Cassette) CZ-RWS3 + CZ-RWRD3 (1-WAY Cassette) CZ-RWS3 + CZ-RWRT3 (Ceiling Mounted) CZ-RWS3 + CZ-RWRC3 (All split type) | 1 unit each |
| (1) Group control <ul style="list-style-type: none"> Batch remote control on all indoor units. Operation of all indoor units in the same mode. Up to 8 units can be connected. The sensor is the body sensor, and thermostat ON/OFF setting in regard to the temperature set by the remote controller is possible for each indoor unit. | Wired remote controller CZ-RTC4,CZ-RTC5B,CZ-RTC6 Wireless remote controller + Receiver CZ-RWS3 (Wall Mounted/ Mini Cassette) CZ-RWS3 + CZ-RWRL3 (4-WAY Cassette) CZ-RWS3 + CZ-RWRL3 (2-WAY Cassette) CZ-RWS3 + CZ-RWRD3 (1-WAY Cassette) CZ-RWS3 + CZ-RWRT3 (Ceiling Mounted) CZ-RWS3 + CZ-RWRC3 (All split type) | 1 unit |
| (2) Main/sub remote control <ul style="list-style-type: none"> Max 2 remote controllers per indoor unit. (Main remote controller can be connected) The button pressed last has priority. Timer setting is possible even with the sub remote controller. (When using ECONAVI sensor, only one remote controller is possible to connect at indoor unit) | Wired remote controller CZ-RTC4,CZ-RTC5B,CZ-RTC6 Wireless remote controller + Receiver CZ-RWS3 (Wall Mounted/ Mini Cassette) CZ-RWS3 + CZ-RWRL3 (4-WAY Cassette) CZ-RWS3 + CZ-RWRL3 (2-WAY Cassette) CZ-RWS3 + CZ-RWRD3 (1-WAY Cassette) CZ-RWS3 + CZ-RWRT3 (Ceiling Mounted) CZ-RWS3 + CZ-RWRC3 (All split type) | As required |

SYSTEM EXAMPLE FSV

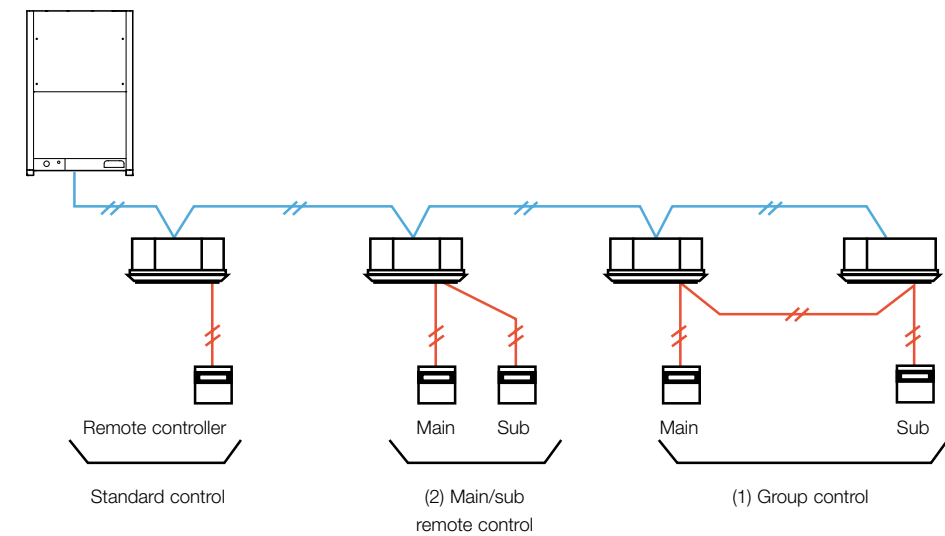

NOTE: Connectable number of controllers, controller combination, connectable indoor units, remote control maximum wiring length are different between the controller. Please confirm the installation instructions of controller or consult with Panasonic service center.

Timer remote controller (CZ-RTC4)



Dimensions
H 120 x W 120 x D 20 mm

Basic remote controller ON/OFF

- Operation mode changeover (Cooling, Heating, Dry, Auto, Fan).
- Temperature setting (Cooling/Dry: 18-30 deg Heating: 16-30 deg).
- Fan speed setting H/ M/ L and Auto.
- Air flow direction adjustment.
- ECONAVI on/ off*

Time Function 24 hours real time clock

- Day of the week indicator.

Weekly Programme Function

- A maximum of 6 settings/day and 42 settings/week can be programmed.

Outing Function

- This function can prevent the room temperature from dropping or rising when the occupants are out for a long time.

Sleeping Function

- This function controls the room temperature for comfortable sleeping.

Max. 8 indoor units can be controlled from one remote controller

Remote control by main remote controller and sub controller is possible

Max. 2 remote controllers (main remote controller and sub controller) can be installed for one indoor unit.

* Depending on the model, some menus cannot be used.

Wireless remote controller



2-WAY Cassette
CZ-RWS3 +
CZ-RWRL3



4-Way Cassette
CZ-RWS3 +
CZ-RWRU3



Ceiling Mounted
CZ-RWS3 +
CZ-RWRT3



1-WAY Cassette
CZ-RWS3 +
CZ-RWRD3



For all indoor units
CZ-RWS3 +
CZ-RWRC3



Wall /
Mini Cassette
CZ-RWS3

Remote control by main remote controller and sub controller is possible

- Max. 2 remote controllers (main remote controller and sub controller) can be installed for one indoor unit.

When CZ-RWS3 is used, wireless control becomes possible for all indoor units

- When a separate receiver is set up in a different room, control from that room also becomes possible.
- Automatic operation by means of the emergency operation button is possible even when the remote controller has been lost or the batteries have been exhausted.

In addition, there are other functions such as temperature setting, operation switching, airflow direction/fan speed setting, etc

Ventilation independent operation is possible

When commercial ventilation fans or heat-exchange ventilation fans have been installed, they can be operated with this remote control (interlocked operation with the indoor unit or independent ventilation ON/OFF).

Timer Operation

Schedule timer (CZ-ESWC2)



Dimensions
H 120 x W 120 x D 16 mm

Up to 64 groups (max 64 indoor units) can be controlled divided into 8 timer groups

• Six program operations (Operation/Stop/ Local permission/ Local prohibition) per day can be set in a program for one week

- Only operation or stop, remote controller local permission or remote controller local prohibition, and their respective combinations are possible. (Operation + local permission, stop + local prohibition, only local permission, etc.)
- Local prohibition and the combination of the three items of temperature setting, mode change, and operation/stop can be set at the time of installation.

- A function for pausing the timer in case of national holidays has been added, and timer operation also can be stopped for a long time

- By setting holidays or operation stop within one week, the timer can be paused just for that week.
- All timer settings can be stopped with the timer "ON/OFF effective" button. (Return to timer operation is made by pressing the button again.)

The power supply for the schedule timer is taken from one of the following.

1. Control circuit board (T10) of a nearby indoor unit (power supply wiring length: within 200m from the indoor unit).
2. System controller (power supply wiring length: within 100 m from the indoor unit).

When the power supply for the schedule timer is taken from the control circuit board of the indoor unit, that indoor unit cannot be used with other control devices using the T10 terminal.

As operation mode and temperature settings are not possible with the schedule timer, it must be used together with a remote controller, a system controller, an intelligent controller, etc. Also, as it does not have an address setting function, the control function of a system controller etc. must be used for address setting.

Connection example 1 (POWER SUPPLY FROM THE INDOOR UNIT)

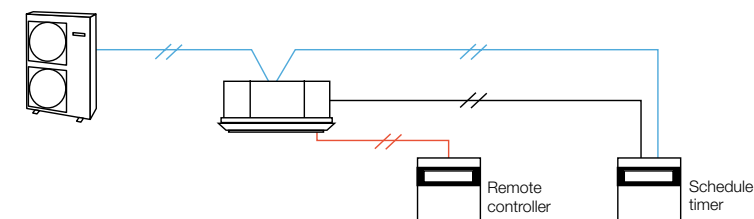

Connection example 2 (POWER SUPPLY FROM THE SYSTEM CONTROLLER AND ON/OFF CONTROLLER)

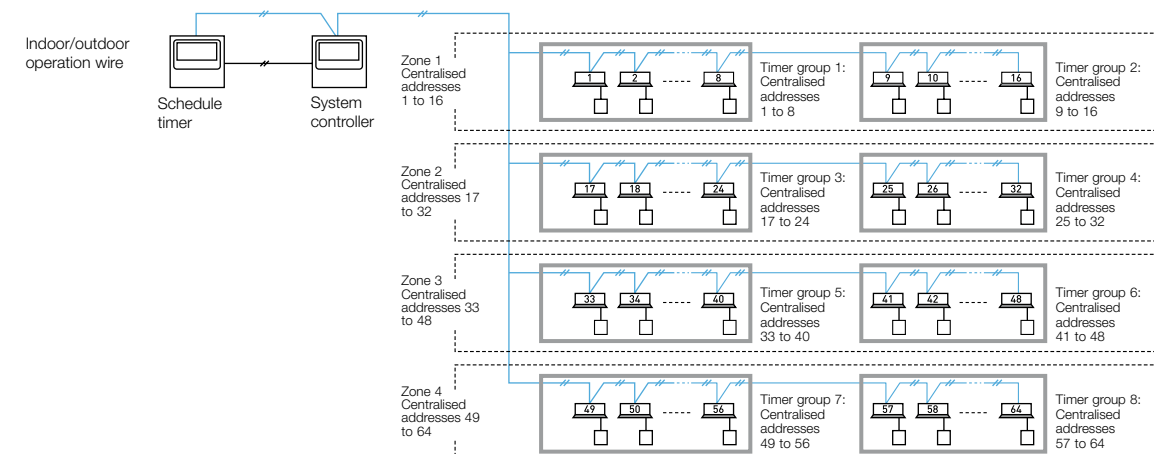

Centralised Control Systems

System controller (CZ-64ESMC3)

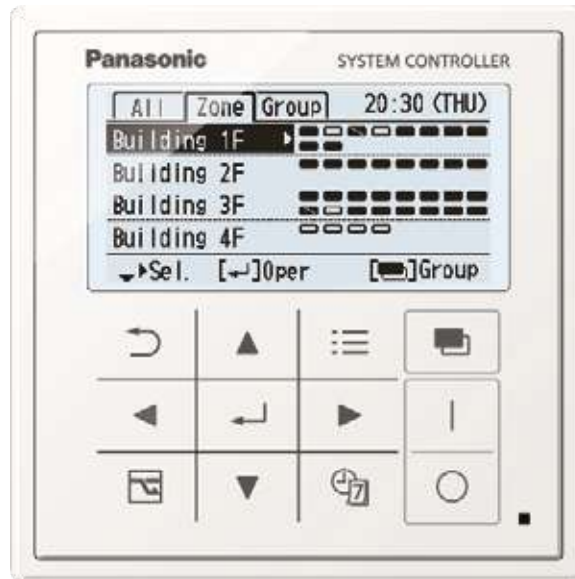

Dimensions
H 120 x W 120 x D 16 + 52
(embedding dimension mm)

Power supply: AC 100 to 240 V
I/O part:
Remote input part (effective voltage:DC24V) All operation, All stop, Demand 1, Demand 2
Remote output part (non voltage contact) Operation, Alarm (external power supply within DC 30V, max 0.5A)
Total wiring length : 1 km

Individual control is possible for max 64 groups, 64 indoor units.

- Control of 64 indoor units divided into 4 zones. (One zone can have up to 16 groups, and one group can have up to 8 units.)
- Control is possible for ON/OFF, operation mode, fan speed, air flow direction, operation monitoring, alarm monitoring, ventilation, remote controller local operation prohibition, etc.

Prohibition setting for Remote controller operation

| Setting mode | ON/OFF | Mode | Temperature | Fan speed | Flap |
|--------------|--------|------|-------------|-----------|------|
| Permit | ● | ● | ● | ● | ● |
| Prohibit 1 | — | ● | ● | ● | ● |
| Prohibit 2 | — | — | — | ● | ● |
| Prohibit 3 | ● | — | — | ● | ● |
| Prohibit 4 | ● | — | ● | ● | ● |

In case of joint use with a wireless remote controller, there are limitations for the control mode. Please use only with setting "Permit" and "Prohibit1 (prohibition for ON/OFF)".

*Contents for Prohibit 1-4 can be modified.
● : Operation from the remote controller is possible.
— : Operation from the remote controller is prohibited.

- **Joint use with a remote controller, an intelligent controller, etc. is possible**
(The maximum number of connectable system controllers is 10, including other central controllers on the same circuit.)
(In case of joint use with a wireless remote controller, there are limitations for the control mode. Please use only with setting "Permit" and "Prohibit1 (prohibition for ON/OFF)".)
- **Control of systems without a remote controller and of main/sub systems (a total of up to 2 units) is possible**
- **Weekly timer function**
 - 8 programs per day (with ON/OFF/Mode/Temperature/Central control setting items) for 1week (7days) can be set.
 - Special holiday setting can ignore the timer operation temporary by keeping original timer setting. (Special holiday setting can be removed by same setting display.)
- **5 types of Energy saving function**
Set temperature automatic return / Set temperature range limitation / Off remind / Off timer operation / Demand control timer

- A control mode corresponding to the use condition can be selected from 10 patterns

A : Operation mode: Central control mode or remote control mode can be selected

Central control mode: The system controller is used as centralised control device. (Setting from a remote controller can be prohibited by prohibiting local operation from the system controller.)

Remote control mode: The system controller is used as a remote controller. (Setting from the system controller can be prohibited by prohibiting local operation from another central control unit.)

B : Controlled unit number mode: All mode or zone 1, 2, 3, 4 mode can be selected

All mode: All, zone, or group unit can be selected.

Zone 1, 2, 3, 4 mode: Setting is possible only for the indoor units of zone 1, 2, 3, or 4.

| Connection example | | A Operation mode | |
|-------------------------------|-------------|----------------------------------|---------------------------------|
| | | Central control mode | Remote control mode |
| B Controlled unit number mode | All mode | All central control Example 1 | All remote control |
| | Zone 1 mode | Zone 1 central control Example 2 | Zone 1 remote control |
| | Zone 2 mode | Zone 2 central control Example 3 | Zone 2 remote control Example 3 |
| | Zone 3 mode | Zone 3 central control Example 4 | Zone 3 remote control |
| | Zone 4 mode | Zone 4 central control Example 5 | Zone 4 remote control Example 5 |

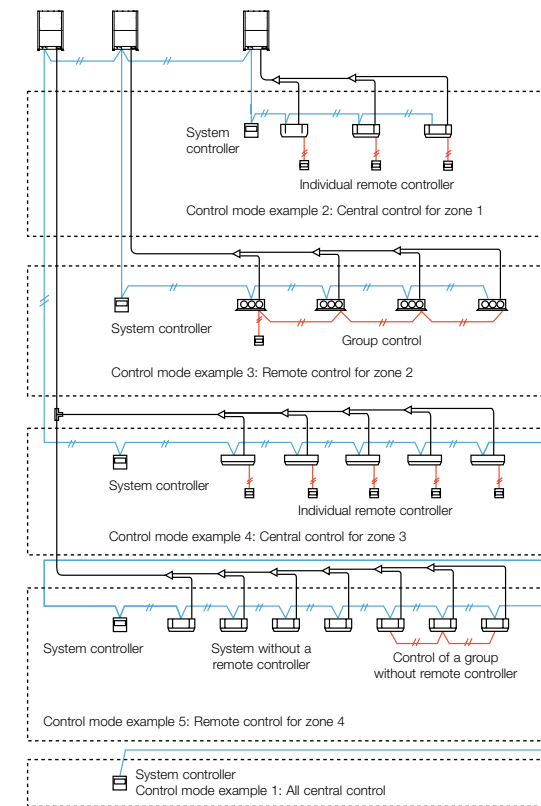

ON/OFF controller (CZ-ANC3)

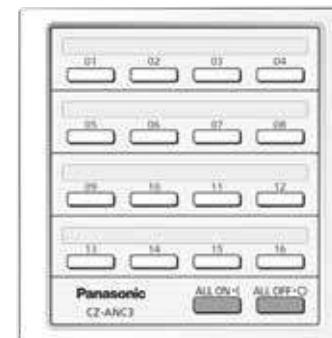

Dimensions
H 121 x W 122 x D 14 + 52
(embedding dimension mm)

Power supply: AC 100 to 240 V
I/O part:
Remote input (effective voltage: within DC 24 V): All ON/OFF
Remote output (allowable voltage: within DC 30 V): All ON, All alarm

- 16 groups of indoor units can be controlled.
- Collective control and individual group (unit) control can also be performed.
- Up to 8 ON/OFF controller (4 main, 4 sub) can be installed in one link system.
- The operation status can be determined immediately.

Intelligent controller (CZ-256ESMC3)



Touch panel

Dimensions
H 240 x W 280 x D 85 mm
Power supply AC 100 to 240 V (50/60 Hz)
LCD: 10.4 in. TFT, XGA(1024 x 768), LED backlight

Product Features

- **10.4 in., Large, easy-to-use color LCD**
 - With smartphone like operations, such as swiping and flicking
- **Enhanced energy-saving control functions**
 - Packed with demand functions
 - Set temperature auto return settings, Auto shutoff, Set temperature range limit settings
- **Energy Visualization**
 - Displays electricity & gas usage distribution
 - Supports energy-saving plans with graph display function

New Features

- **Max 256 indoor unit [4 links x 64 units] can be controlled. In case of three or more systems [more than 128 units], a communication adaptor CZ-CFUNC2 must be installed for three or more links.**
- Operation is possible as batch, in zone units, and in group units.
- ON/OFF, operation mode setting, temperature setting, for fan speed setting, air flow direction setting (when used without a remote controller) and remote controller local operation prohibition [prohibition 1,2,3,4] can be done
- Graph display [trends, comparisons]
- ECONAVI ON/OFF

- Outdoor unit quiet operation ON/OFF
- Energy-saving Functions
- Event control [such as equipment linkage]
- Limitation contents for prohibited operation

Prohibition means limitation of the operation contents from the remote controller. It is also possible to change the prohibition items.

Limitation contents (Limitations can be user defined)

- Individual There is no limitation for the operation of the remote controller. However, the contents will be changed to the contents of the controller operated last. (Last-pressed priority.)
- Prohibition 1 The remote controller cannot be used for ON/OFF. (All other operations are possible from the remote controller.)
- Prohibition 2 The remote controller cannot be used for ON/OFF, operation mode change and temperature setting. (All other operations are possible from the remote controller.)
- Prohibition 3 The remote controller cannot be used for operation mode change and temperature setting. (All other operations are possible from the remote controller.)
- Prohibition 4 The remote controller cannot be used for operation mode change. (All other operations are possible from the remote controller.)

Remote Control

The LAN terminal on this unit enables you to connect it to a network. Connecting to internet will enable you to operate the unit and check the status using a PC from remote location.



Display image on the remote PC is same design as the controller unit.

System configuration

The following is an example of a system configuration.

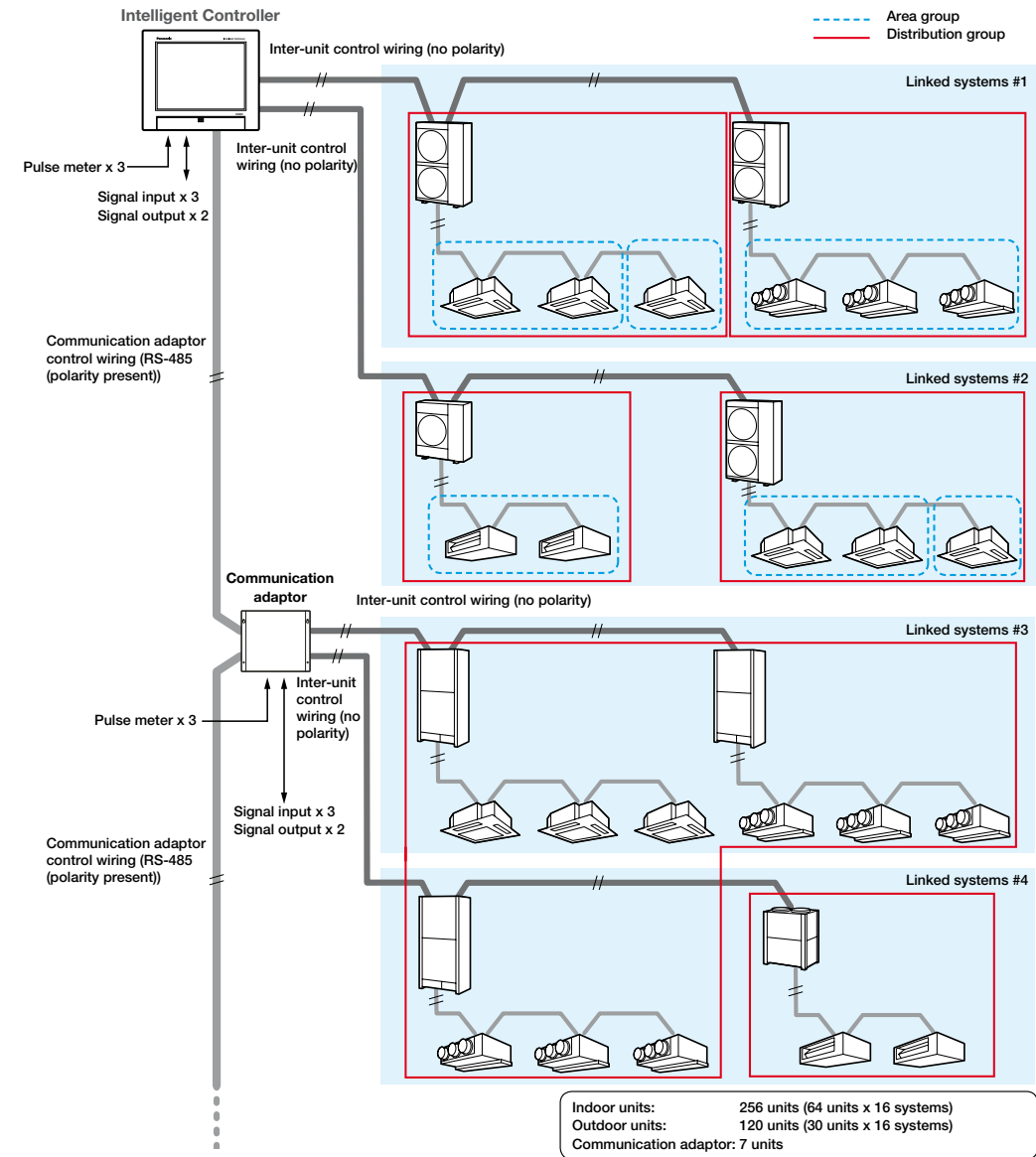

Communication adaptor (CZ-CFUNC2)



* Required when more than 129 indoor units are connected.



Panasonic total air conditioning management system P-AIMS

P-AIMS Basic software / CZ-CSWKC2

Up to 1024 indoor units can be controlled by one PC

Functions of basic software

- Standard remote control for all indoor units
- Many timer schedule programs can be set on the calendar
- Detailed information display for alarms
- CSV file output with alarm history, operating status.
- Automatic data backup to HDD



With 4 upgrade packages the basic software can be upgraded to suit individual requirements

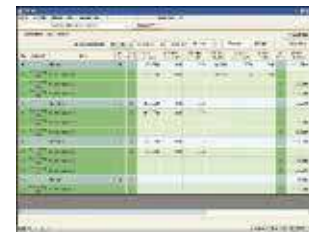

CZ-CFUNC2

The P-AIMS is ideal for large areas/buildings such as shopping centers, universities and office buildings. Each line can have max.8C/A units, and control max.512 units. In total, 1024 indoor units can be controlled by 1 "P-AIMS" PC.

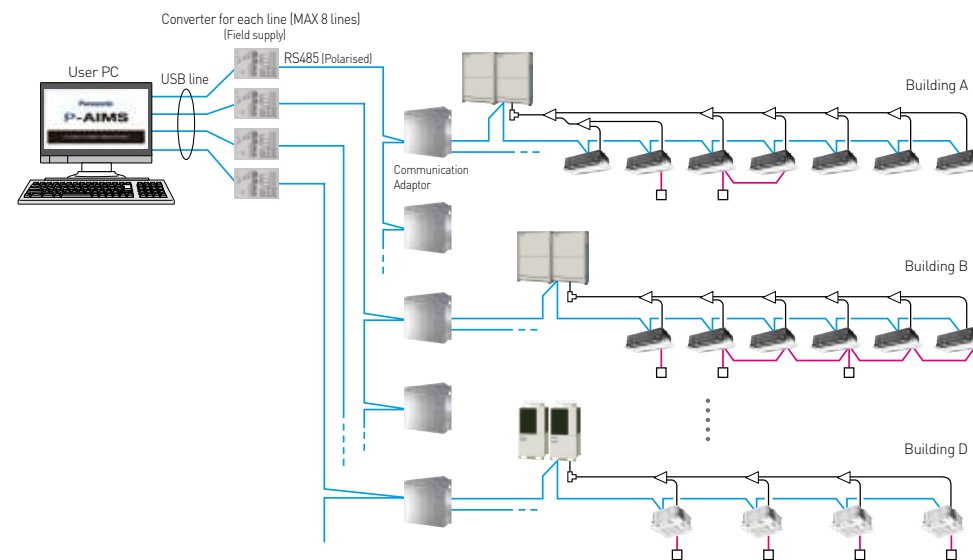

Recommended computer specs (Desktop type)

| | |
|--------------------|--|
| Operating system | Windows 10 Pro 64bit Windows 8.1 Professional 64bit |
| CPU | Intel Core™ i5-6500 3.20GHz or higher (Recommended computer) Intel Core™ i7-7700 3.60GHz or higher (When installing Layout Display Software or using 512 or more indoor units) |
| Memory | 8GB or larger |
| HDD | SSD (Solid State Drive) 250GB or larger |
| Monitor | 1920 x 1080 (full HD) Recommended (1280 x 1024 (SXGA) minimum) |
| (Built-in speaker) | 1920 x 1080 (full HD) Required (when installing Layout Display Software) |
| External HDD | 500GB or larger (An external power supply type is preferable because the HDD will be used for backing up data.) |
| LAN | Network adaptor equipped machine (when Web Software or BACnet Communication Software installed) |
| UPS (Field Supply) | Select a UPS with a sine output wave form |

P-AIMS optional software CZ-CSWAC2 for Load distribution

Load distribution calculation for each tenant

- Air-conditioner load distribution ratio is calculated for each unit (tenant) with used energy consumption data (m3, kWh).
- Calculated data is stored with CSV type file.
- Data of last 365 days is stored



P-AIMS optional software CZ-CSWWC2 for Web application

Web access & control from remote station

- Accessing P-AIMS software from remote PC.
- You can monitor/operate FSV systems by using Web browser (Internet Explorer).



P-AIMS optional software CZ-CSWGC2 for Object layout display

Whole system can be controlled visually

- Operating status monitor is available on the layout display.
- Object's layout and indoor unit's location can be checked at once.
- Each unit can be controlled by virtual remote controller on the display.
- Max 4 layout screens are shown at once.



P-AIMS optional software CZ-CSWBC2 for BACnet software interface

Connectable to BMS system

- Can communicate with other equipment by BACnet protocol.
- FSV systems can be controlled by both BMS and P-AIMS.
- Max 255 indoor units can be connected to 1 PC (that has P-AIMS basic & BACnet software).

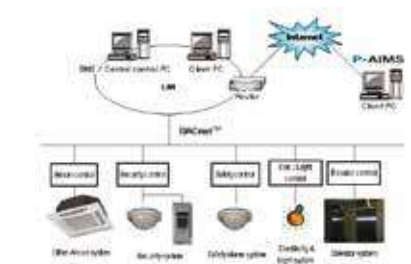

T10 Terminal for External Control (Digital Connection)

Connecting an FSV indoor unit to an external device is easy. The T10 Terminal featured in the electronic circuit board of all indoor units enables digital connection to external devices.



1. T10 Terminal Specification (T10:CN061 at indoor unit PCB)

- Control items: 1. Start/stop input (eg hotel key card, push button operation)
2. Remote controller prohibit input
3. Operation status output (eg fresh air fan)
4. Fault status output

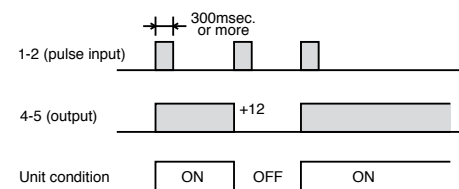

NOTE: The wire length from indoor unit to the Relay must be within 2.0m. Pulse signal changeable to static with JP cutting. (Refer to JP001)

Example of wiring

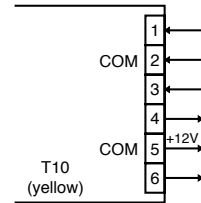

Condition

- 1-2 (Pulse input): Unit ON/OFF condition switching with a pulse signal. (1 pulse signal: shortage status more than 300msec.or more)
- 2-3 (Static input): Open/ Operation with Remote is permitted.(Normal condition) Close/ Remote controller is prohibited.
- 3-4 (Static output): 12V output during the unit ON. / No output at OFF.
- 4-5 (Static output): 12V output when some errors occur / No output at normal.

2. Usage Example

Forced OFF control

Condition

1-2 (Static input): Close/ Operation with Remote is permitted. (Normal condition) Open/ Unit is forcibly OFF and Remote controller operation is prohibited.

Example of wiring

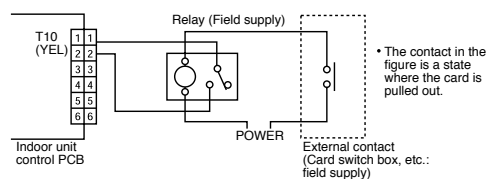

NOTE: The wire length from indoor unit to the Relay must be within 2.0m

Operation ON/OFF signal output

Condition

4-5 (Static output): 12V output during the unit ON / No output at OFF

Example of wiring

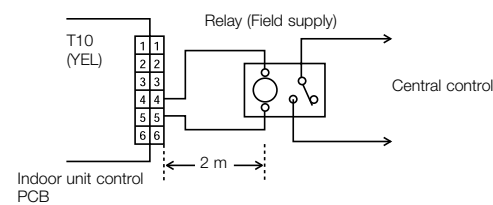

NOTE: The wire length from indoor unit to the Relay must be within 2.0m. Pulse signal changeable to static with JP cutting. (Refer to JP001)

Interfaces for External Control (Digital Connection)

Seri-Para I/O unit for each indoor unit (CZ-CAPBC2)



System example

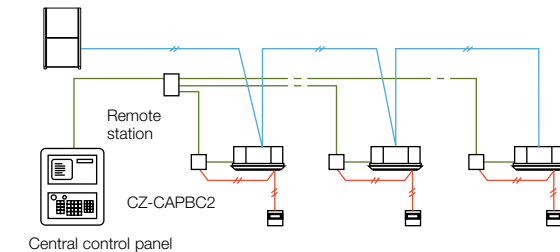

- Control and status monitoring is possible for individual indoor unit (1 group).
- In addition to operation and stop, there is a digital input function for air speed and operation mode.
- Temperature setting and measuring of the indoor suction temperature can be performed from central monitoring.
- The analog input for temperature setting is 0 to 10 V, or 0 to 140 Ohm.
- Power is supplied from the T10 terminal of the indoor units.
- Separate power supply also is possible (in case of suction temperature measuring).

Interface adaptor (CZ-CAPC3)



System example

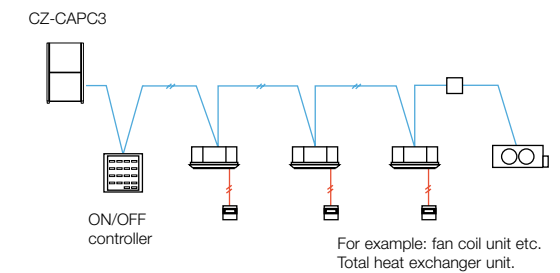

- Control and status monitoring is possible for individual indoor unit (or any external electrical device up to 250 V AC, 10 A) by contact signal.

Seri-Para I/O unit for outdoor unit (CZ-CAPDC2)



System example

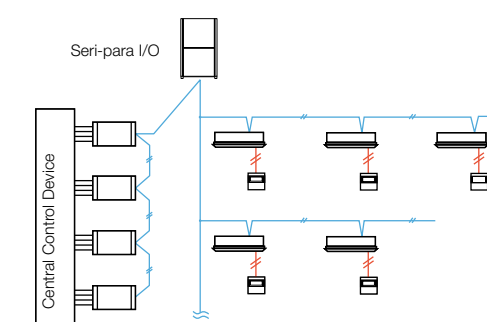

- Dimensions: H 80 x W 290 x D 260 mm
- Power supply: Single phase 110-120/220-240 V (50/60 Hz), 18 W
- Input: Batch operation/Batch stop (non-voltage contact/DC 24 V, pulse signal), Cooling/Heating (non-voltage contact/static signal), Demand 1/2 (non-voltage contact/static signal) (Local stop by switching)
- Output: Operation output (non-voltage contact), Alarm output (non-voltage contact)
- Wiring length: Indoor/Outdoor operation lines: Total length 1 km. Digital signal: 100 m or shorter

- This unit can control up to 4 outdoor units.
- From the centre control device, mode changing and batch operation/batch stop are possible.
- Required for demand control.

Serial Interface for 3rd Party External Controller

Example of 3rd party BMS connection with CZ-CFUNC2
(For the detail please consult to authorized dealer)

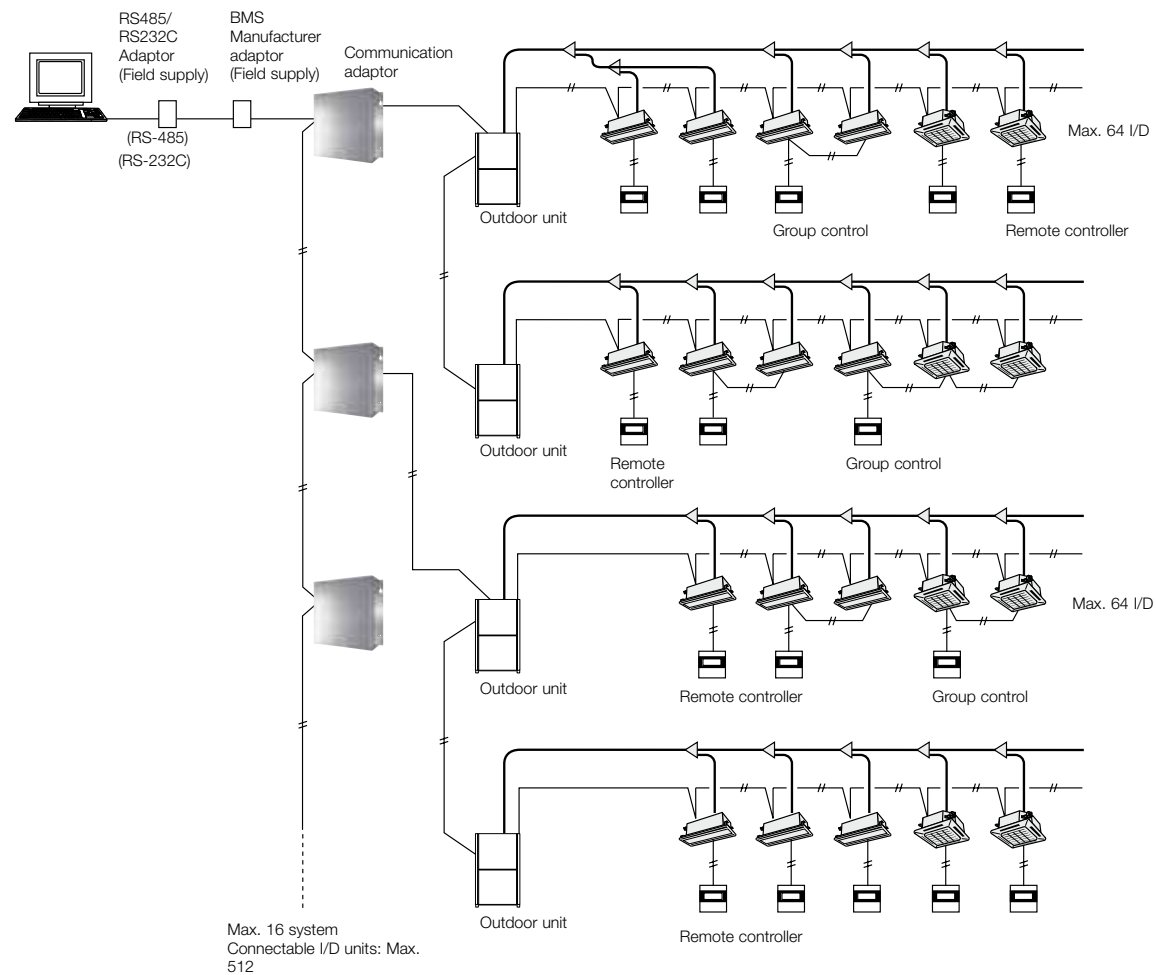

| Functions via communication adaptor [CZ-CFUNC2] | |
|---|--------------------------|
| A/C unit settings | Unit ON/OFF |
| | Mode-change |
| | Room temperature setting |
| | Fan speed setting |
| | Flap setting |
| | Central control setting |
| | Filter-sign clear |
| | Alarm reset |
| A/C unit status | Unit ON/OFF status |
| | Operation mode |
| | Setting temperature |
| | Fan speed status |
| | Flap status |
| | Central control setting |
| | Filter-sign situation |
| | Alarm code |

Communication Adaptor (CZ-CFUNC2)

Up to 128 indoor units can be connected to one Communication Adaptor.

Serial Interface for LonWorks Network

LonWorks Interface (CZ-CLNC2)



- This interface is a communications converter for connecting LonWorks to the control network of FSV.
- From the host connected to LonWorks, basic settings and status monitoring is possible for up to 16 groups of indoor units.

System example

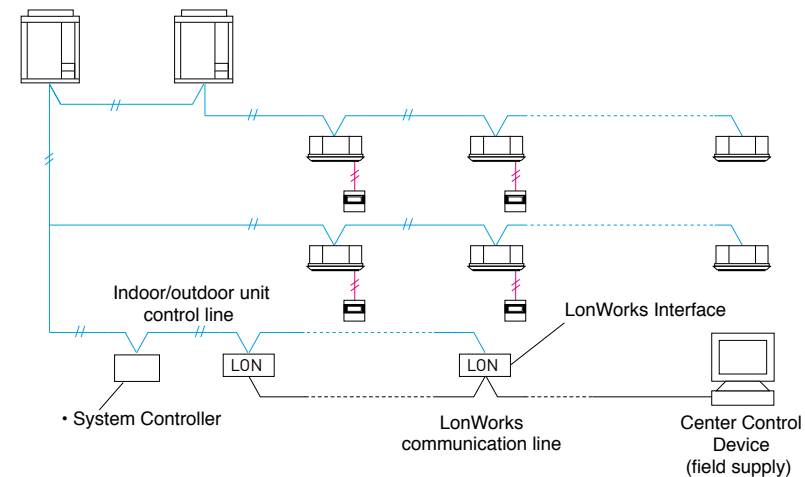

Functions

| | | |
|---|---|---------------------------------------|
| A/C unit settings from the LonWorks communicator | Settings for each group of indoor units | Start/stop |
| | | Temp. setting |
| | | Operation mode |
| | | Option 1 settings |
| | | Option 2 settings |
| A/C unit status notifications made to the LonWorks communicator | Settings for all units | Emergency stop |
| | | Start/stop |
| | | Temp setting |
| | | Operation mode |
| | | Option 1 settings |
| | | Option 2 settings |
| | | Alarm status |
| | | Indoor units with active alarms |
| | | Room temp. |
| | | A/C unit status |
| Configuration properties | | Transmission intervals settings |
| | | Minimum time secured for transmission |

FSV Controller External Dimensions

SIMPLIFIED WIRED REMOTE CONTROLLER (CZ-RTC6)

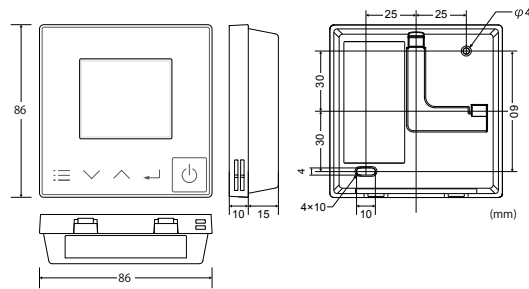

HIGH-SPEC WIRED REMOTE CONTROLLER (CZ-RTC5)

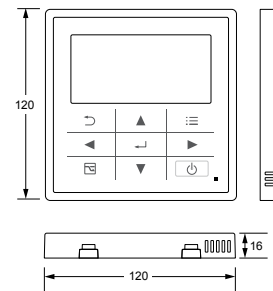

COMMUNICATION ADAPTOR (CZ-CFUNC2)

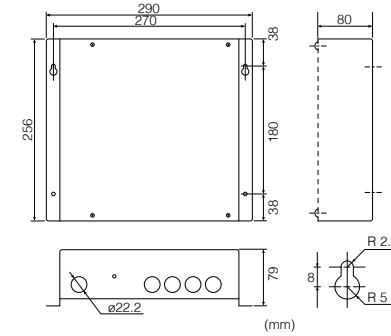

INTELLIGENT CONTROLLER (CZ-256ESMC3)

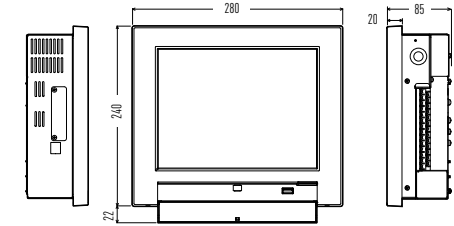

TIMER REMOTE CONTROLLER (CZ-RTC4)

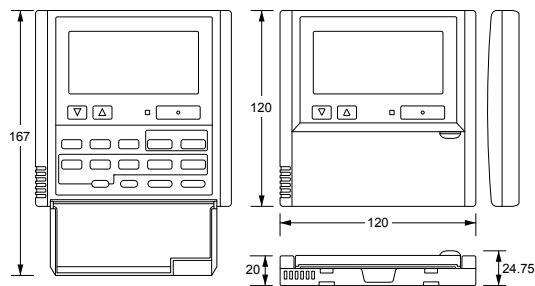

WIRELESS REMOTE CONTROLLER (CZ-RWS3)

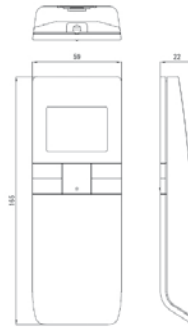

ON/OFF CONTROLLER (CZ-ANC3)

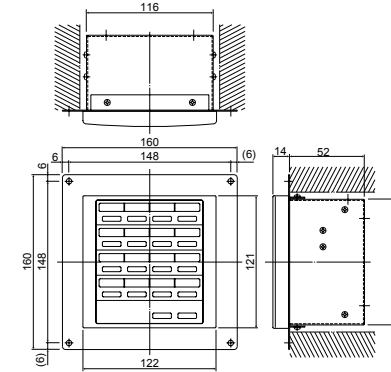

SERI-PARA I/O UNIT FOR EACH INDOOR UNIT (CZ-CAPBC2)

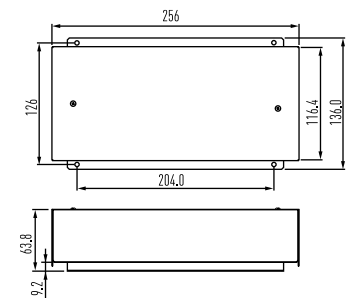

SEPARATE RECEIVER FOR WIRELESS REMOTE CONTROLLER (CZ-RWSC3)

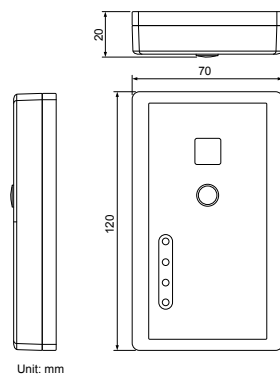

SYSTEM CONTROLLER (CZ-64ESMC3)

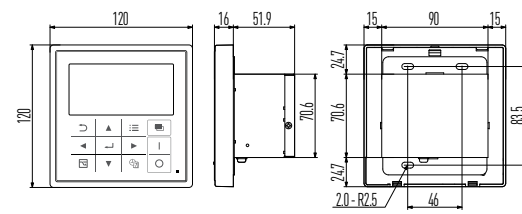

LONWORKS INTERFACE (CZ-CLNC2)

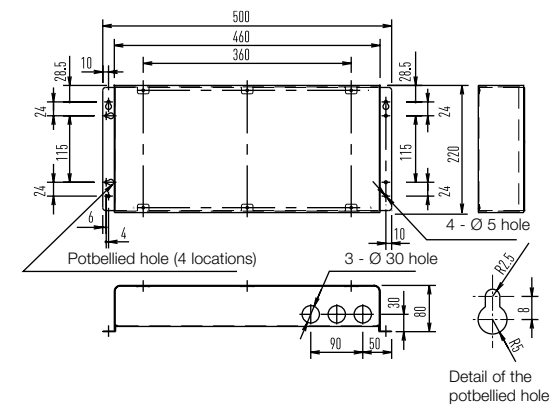

SERI-PARA I/O UNIT FOR OUTDOOR UNIT (CZ-CAPDC2)

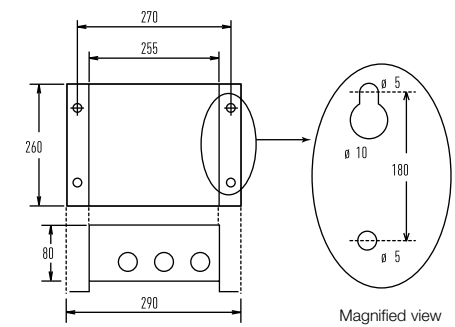

ECONAVI SENSOR (CZ-CENSC1)

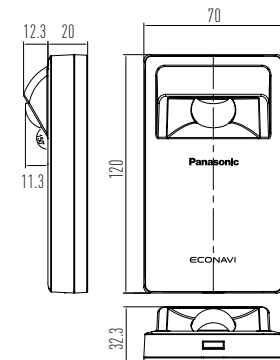

REMOTE SENSOR (CZ-CSRC3)

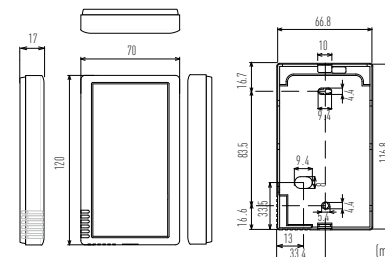

VRF Renewal

An important drive to further reduce the potential damage to our ozone



R22 is a HCFC and classified as an ozone depleting substance banned under the Montreal Protocol. Many existing R22 VRF Systems will need to be replaced over the coming years by more modern and efficient R410A VRF Systems.

Panasonic takes proactive action to switch to R410A refrigerant

Recognising consumers' anxiety and financial difficulties to adapt to the new R22 regulations, Panasonic developed a new cost-effective and simple solution to switch to R410A refrigerant.

What is Panasonic VRF Renewal?

Panasonic VRF Renewal enables reuse of good quality existing R22 pipe work to be installed with a new high efficiency R410A system.

What's so unique about Panasonic's solution?

By enabling reuse of existing R22 piping, consumers get to save substantially from reduced installation cost, and without any sacrifices to warranty or performance.

| Ozone Depletion Potential | | |
|---------------------------|-------|-------|
| R22 | HCFCs | 0.055 |
| R410A | HFC | 0 |
| R407C | HFC | 0 |

R22 - The reduction of Chlorine critical for a cleaner future

Before renewing piping, be sure to contact an authorised Panasonic dealer for advice.

VRF Renewal

Panasonic's Renewal system allows a completely new VRF system, indoor and outdoor units, to be installed using the existing systems pipe work. Panasonic's advanced technology enables the system to work with previously installed pipe work by managing the working pressure within the system down to R22 (3.3 bar) levels. This ensures the system works safely and efficiently without loss of capacity.

The new equipment has potential to increase COP/EER by using state of the art inverter compressor and heat exchanger technology.

Having contacted your Panasonic supplier regarding pipe work restrictions and gained approval to use the Panasonic Renewal System there are three main tests that have to be carried out to ensure that the system can be used effectively.

Firstly a thorough inspection of the pipe work must be carried out and any damage must be repaired.

Secondly an oil test has to be carried out to ensure that the system has not been subject to a compressor burnout during its lifetime.

Lastly a VRF Renewal Kit (CZ-SLK2) has to be installed within the pipe work to ensure that the system is cleaned of any oil residue.

VRF Renewal Kit (CZ-SLK2) and Sight Glass

The following shows an overview of the VRF Renewal Kit (CZ-SLK2) that is required when existing tubing is reused. If the exact tube length and tube size of the existing tubing are uncertain, attach a sight glass in accordance with the figure below. It will be used for checking the amount of additional refrigerant charge (calculating the amount in Judgment 4 see page 122).

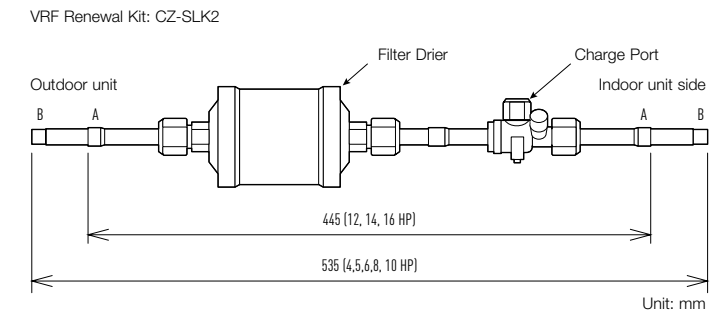

Attaching the Renewal Kit and sight glass

- To adjust the limited pressure level into 3,3 MPa, special setting is necessary on site.
- A filter drier shall be attached to the liquid tubing of each outdoor unit.
- Do not need to remove Renewal Kit after a test run is performed as it can be retained for normal operation.
- When attaching Renewal Kit, be extra careful with regards to installation location and orientation of the filter drier and ball valve. Any mistakes will complicate maintenance work.
- Thermal insulation material (field supply: heat resistance of 80°C or higher and thickness of 10 mm or greater) shall be applied to the Renewal Kit.
- The filter drier of the Renewal Kit may need to be replaced depending on the condition of the existing unit. Use a Danfoss DMB 164 as the replacement filter drier (field supply).

Connecting tube dimensions (Inch mm)

- A Ø 1/2 (12.7) (12,14,16 HP)
- B Ø 3/8 (9.52) (8,10 HP)

Note: If the tube size does not match that of the existing tubing, use a reducer (field supply) to adjust the tube diameter.

Sight glass (field supply)

If the exact tube length and tube size of the existing tubing are uncertain, attach a sight glass to the liquid tubing, and use it to check whether there is an appropriate amount of additional refrigerant charge.

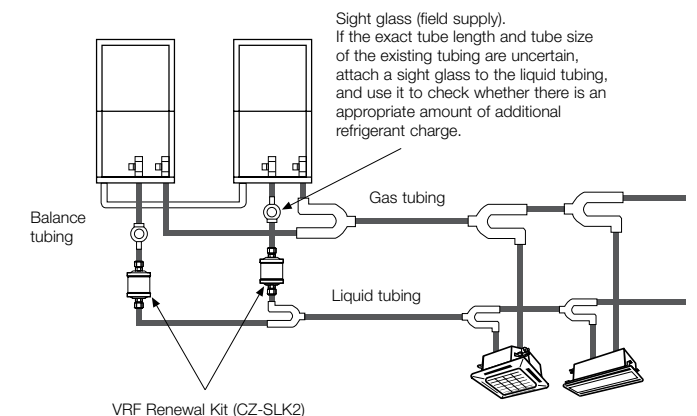

Procedure for VRF Renewal

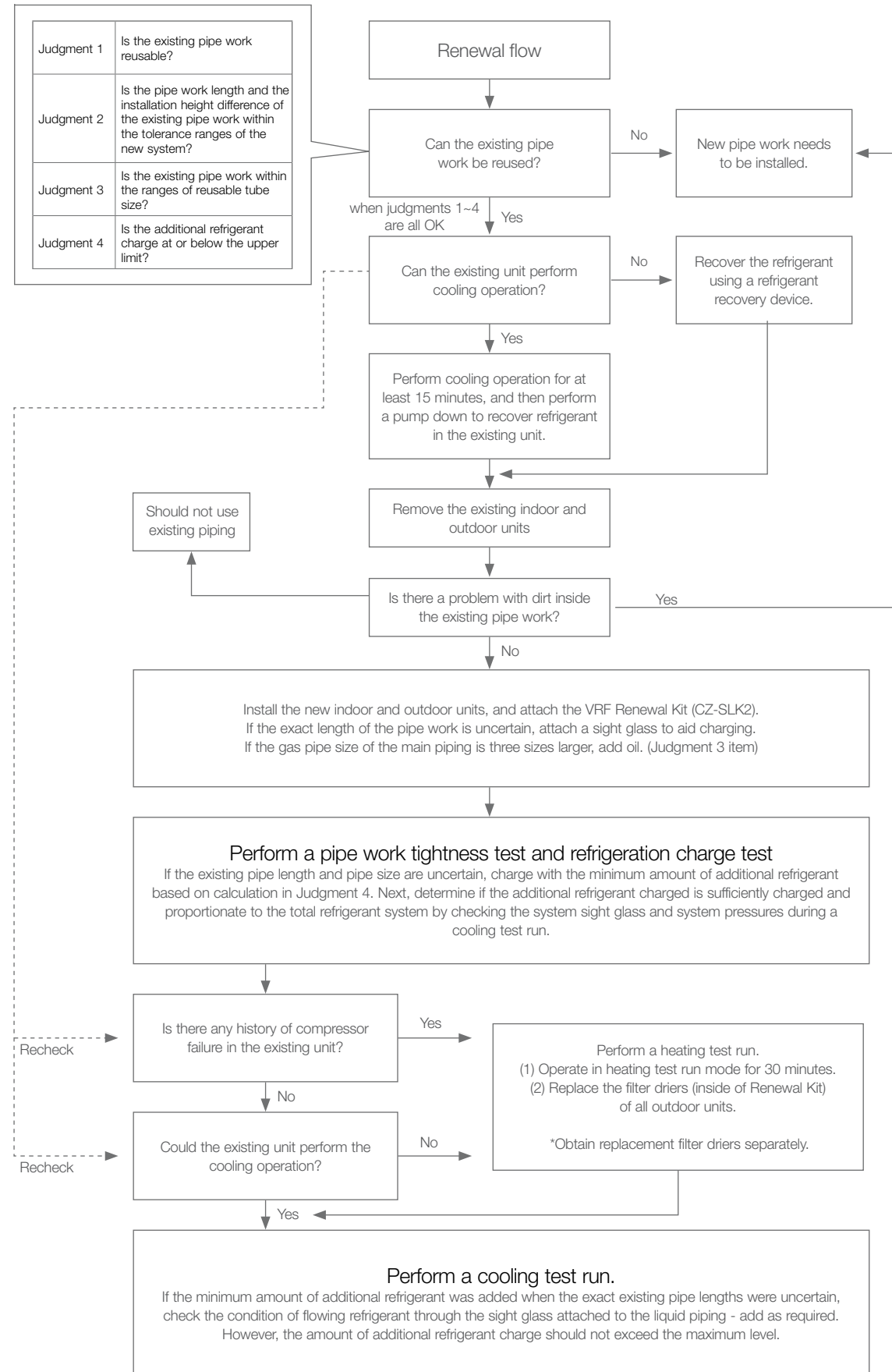

A Globally Trusted Air Conditioning Brand

With roots going back 60 years, the Panasonic Air Conditioning Business Division has grown to become a multinational company recognised around the world. Driven by a never-ending quest for product innovation, the group has evolved from manufacturing compressors to providing comprehensive air conditioning solutions. Panasonic has become a brand that people trust to deliver products with superior quality and reliability.

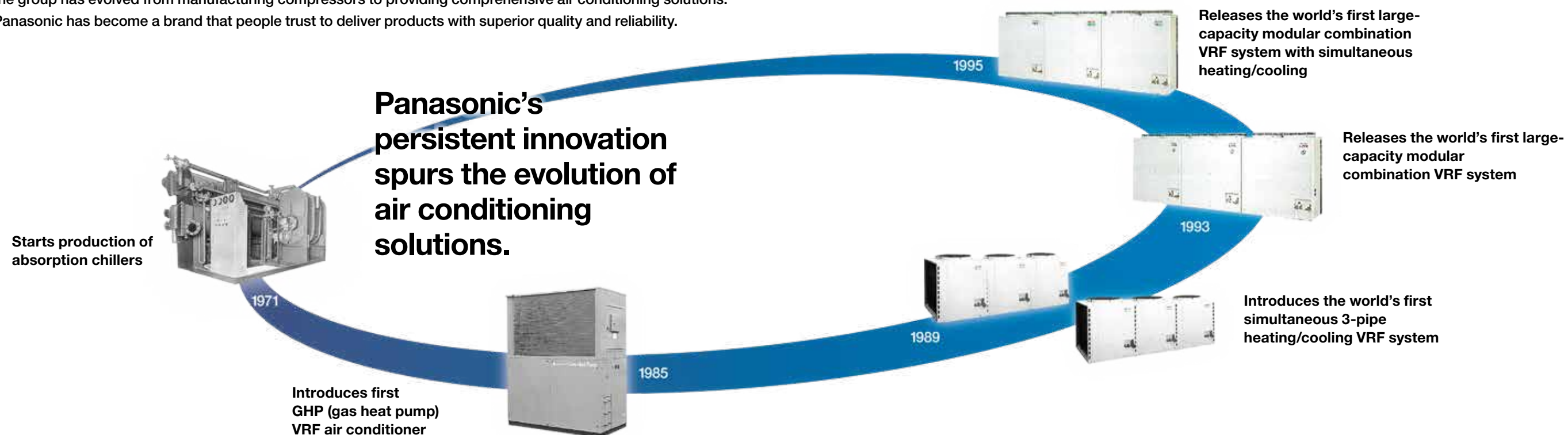

1957

- Start of the Home Cooler business

1958

- Panasonic (using the National brand) introduces its first Home Cooler, a window-type air conditioner model



- Electrical Appliance Business Group (Kadoma) starts manufacture of Home Coolers
- Sales of Home Coolers begin

1961

- Starts exports of Home Coolers to South Vietnam

1965

- Launches Room Coolers



1968

- Begins development of rotary compressors
- The high efficiency and quality of these compressors draw interest from domestic and overseas air conditioner manufacturers
- External sales begin

1972

- MAICO, the Division's first overseas manufacturing base, established in Malaysia
- Starts export from MAICO to Japan, Indonesia, Australia, and other markets
- Begins operating twin-based system out of Japan and Malaysia



1983

- Launches inverter air conditioners
- Starts sale of Panasonic's first inverter air conditioners
- Inverters grow to become a core technology in the air conditioner industry
- Starts shipment of air conditioners to Panasonic America



1985

- Begins development of scroll compressors
- Scroll compressors bring high efficiency, low noise, and low vibration in comparison to rotary compressors

1990

- Launches world's first air conditioner equipped with compact scroll compressor

1993

- Establishes Matsushita-Wanbao (Guangzhou) Air Conditioner (MWAC)
- Establishes Matsushita-Wanbao (Guangzhou) Compressor (MWCC)
- Establishes Matsushita Air Conditioner Engineering (Matsushita ACE)

2003

- Launches automatic filter-cleaning function for air conditioners (AC robot)



- Debuts quiet, lightweight, compact EcoCute systems with improved energy-saving technology
- EcoCute adopts highly efficient, accumulator-less CO₂ scroll compressor
- CO₂ heat-pump hot water heater (EcoCute) uses non-toxic, non-combustible natural refrigerant (CO₂) instead of Freon, to reduce environmental impact
- Begins production of new energy-saving mini-VRF series multi-split packaged air conditioners for residential use



2005

- Panasonic products become extremely successful in Japan's air conditioner market
- Innovations such as airstream robots and motion sensors help grow Panasonic's market share

2006

- Cumulative global production of Panasonic compressors reaches 200 million units

2008

- Starts air-to-water heat pump business in Europe

- Hot water heating considered an eco-friendly alternative to conventional fuel-type heating systems
- At the Energy Conservation Grand Prize awards, Panasonic air conditioners won the Chairman Prize of ECCJ, whilst EcoCute won the Director General Prize of Agency of Natural Resources and Energy (prizes presented by Energy Conservation Center of Japan)
- nanoe technology installed on room air conditioners



2009

- Establishes sales company in Europe (PHAAE) dedicated to selling air conditioners
- Panasonic HA Air-Conditioning Europe (PHAAE) strengthens company's commercial air conditioning business

2010

- Begins collaboration with SANYO air conditioner business
- Through share exchange, SANYO and Panasonic Electric Works become wholly owned subsidiaries

2011

- Launches FSV series of large-capacity VRF air conditioners

2012

- New Panasonic Group inaugurated

2013

- Expands VRF operation in Malaysia



2016

- Partnership started with Schneider Electric
- At the Energy Conservation Grand Prize awards, the room air conditioner "WX series" won the Minister Prize of Economic, Trade and Industry (prize presented by Energy Conservation Center of Japan)



Reliability and Durability

At Panasonic, we believe that the best air conditioner is one that works quietly and effectively in the background whilst minimising its impact on the environment. People who use our products can look forward to long years of high-quality performance without the need for constant maintenance. As part of our rigorous design and development process, Panasonic air conditioners undergo a variety of stringent tests to ensure their effectiveness and long-term reliability. Tests for durability, waterproofing, shock resistance, and noise are conducted on component parts or on the finished products themselves. As a result of all of these painstaking efforts, Panasonic air conditioners meet even the most demanding industrial standards and regulations in every country where they are sold.



Applying advanced technologies that truly make life better, we live by an unparalleled commitment to product quality. Our approach to product development originates in the DNA of Japanese craftsmanship. Panasonic is building on the Japanese tradition of uncompromising quality control worldwide, developing and manufacturing fine products and delivering them to customers everywhere.



Testing laboratory Panasonic Gunma, Japan (PAPARS)

Durability

At Panasonic we know the importance of a long service life with minimal maintenance. That's why we subject our air conditioners to a wide range of stringent durability tests.



Long-Term Durability Test

To ensure durability and stable operation for many years, we conduct a long-term continuous operation test under conditions that are much more severe than actual operating conditions.



Compressor Reliability Test

After the continuous operation test, we remove the compressor from a selected outdoor unit, disassemble it, and examine the internal mechanisms and parts for potential failure. This helps ensure reliable long-term performance under harsh conditions.



Waterproofing Test

The outdoor unit, which is subject to rain and wind, complies with IPX4 waterproof specifications. Contact sections on printed circuit boards are resin-potted to prevent adverse effects caused by exposure to water (an unlikely occurrence).



A resin-potted circuit board

International Standard Quality

To uphold the company's reputation around the world, Panasonic strives continuously to offer the highest quality with the lowest possible environment impact.



The strength of the resin material used in a propeller fan is confirmed by a tension test

Reliable Parts That Meet or Exceed Industrial Standards

In every country where they are sold, Panasonic air conditioners comply with all required industrial standards and regulations. In addition, Panasonic conducts stringent testing to ensure the reliability of parts and materials.



RoHS / REACH Compliant Parts

All Panasonic parts and materials comply with Europe's strict RoHS/REACH environmental regulations. During the development and production of parts, stringent inspections are conducted on over 100 materials to ensure that no hazardous substances are included.



Sophisticated Production Process

Panasonic's air conditioner production lines employ state-of-the-art factory automation technologies to ensure products are manufactured efficiently and with uniformly high levels of quality and reliability.

Global Networking of Heating and Cooling Solutions

In any indoor environment, eco-friendly air conditioning plays a vital role in maintaining our health, comfort, and productivity. Whether it's an office, a hotel, or a shopping mall, every building matters. That's why Panasonic has developed energy-efficient large-scale heating and cooling solutions to suit a variety of business applications. As one of the pillars of Panasonic's BtoB operations, our heating and cooling sector provides comprehensive solutions to businesses around the world. Harnessing our advanced technology and extensive on-site expertise, we serve clients in a diverse range of environments throughout the world.

Panasonic air conditioning solutions are designed from the ground up to meet the specific needs of each location, whilst placing a premium on efficiency and reliability. At every stage, we seek to make optimal use of resources and energy to create solutions that benefit the environment.

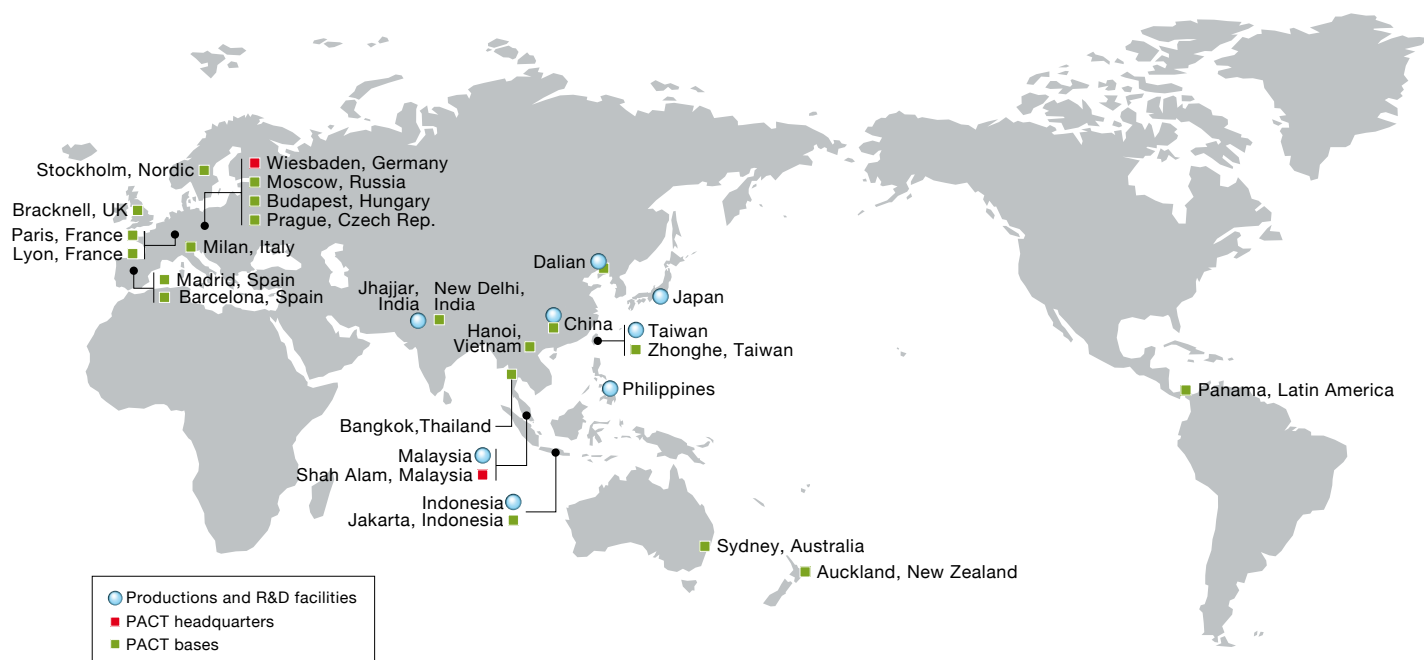

PACT Training Facilities

The 42 Panasonic Air Conditioning Training Centers (PACTs) around the world provide a wide range of support for Panasonic's business-use air conditioning systems. PACT represents Panasonic's unwavering commitment to our sales partners, distributors, and service teams in Europe, Asia, Oceania, and the Americas.



Quality Assurance from Japan to the World

With a diverse network of production and R&D facilities, Panasonic delivers innovative products incorporating cutting-edge technologies that set the standard for air conditioners worldwide. As our business expands globally, we strive to transcend borders with our superior-quality products.

Japan



Heating & Cooling Solutions Business Division, Air-Conditioning Business Unit (Appliances Company) (Shiga, Japan)

Established April 1972
 • Appliances Company HQ
 • Home Appliances Business Group
 • Corporate Engineering Division



Commercial Air-Conditioning Business Unit (Gunma, Japan)

Established July 1959
 • Air conditioners
 • Cold-chain/refrigeration products

Malaysia



PAPAMY Panasonic Appliances Air Conditioning Malaysia Sdn. Bhd.

Established April 1972
 • Air conditioners
 • Air-to-water heat pumps



PAPANADMY Panasonic Appliances Air Conditioning R&D Malaysia Sdn. Bhd.

Established June 1991
 • R&D for air conditioners
 • Air-to-water heat pumps



PAPAMY Compressor

Established January 1987
 • Rotary compressors for air conditioners



PAPAMY Compressor R&D

Established September 1997
 • R&D for rotary compressors

China



PAPANAGZ Panasonic Appliances Air Conditioning (Guangzhou) Co., Ltd.

Established June 1993
 Air conditioners



PAPANADGZ Panasonic Wanbao Appliances Compressor (Guangzhou) Co., Ltd.

Established June 1993
 • Rotary compressors for air conditioners
 • Compressors for automotive air conditioners



PRDCS Panasonic R&D Center Suzhou Co., Ltd.

Established April 2002
 • Air conditioners
 • R&D for home appliance products

PAPANADL Panasonic Appliances Air-Conditioning and Refrigeration (Dalian) Co., Ltd.

Established September 1992
 • Air conditioners

Taiwan



PTW Panasonic Taiwan Co., Ltd.

Established October 1962
 • Air conditioners
 • Automotive air conditioners
 • Home appliance products



PMI Panasonic Manufacturing Indonesia

Established September 1970
 • Air conditioners
 • Home appliance products



PMPC Panasonic Manufacturing Philippines Corporation

Established September 1967
 • Air conditioners
 • Home appliance products

India



PI Panasonic India Pvt. Ltd.

Established December 2012
 • Room Air conditioners

PACT Headquarters and Bases

EUROPE



■ Germany Wiesbaden

■ Nordic Stockholm

■ Hungary Budapest



■ Russia (CIS) Moscow

■ Spain Barcelona



■ Spain Madrid

■ France Paris



■ Italy Milan

■ France Lyon
 ■ Czech Rep. Prague
 ■ UK Bracknell

ASIA



■ Malaysia Shah Alam

■ Vietnam Hanoi

■ India New Delhi



■ Thailand Bangkok

■ China

■ Taiwan Zhonghe

■ Indonesia Jakarta

OCEANIA

■ Australia Sydney

■ New Zealand Auckland

AMERICAS

■ Latin America Panama



Panasonic VRF Global Project References

Panasonic air conditioning systems provides comprehensive solutions to businesses around the world. Harnessing our advanced technology and extensive on-site expertise, we serve clients in a diverse range of environments throughout the world.

HOTEL

Australia Travelodge Hobart



Air Conditioning System:
VRF 3-way FSV MF2 series 8 systems
Indoor Units: 116 units
Cooling Capacity:
302 kW / 86 USRT

Indonesia Patra Jasa Hotel



Air Conditioning System:
VRF 2-way FSV ME1 series 14 systems
Indoor Units: 132 units
Cooling Capacity:
677 kW / 193 USRT

Spain Hotel Claris 5 GL



Air Conditioning System:
VRF 2-way ME1&LE1 series 11 systems
VRF 3-way MF1 series 14 systems
Indoor Units: 233 units
Cooling Capacity: 769 kW / 218 USRT

Spain Monument Hotel



Air Conditioning System:
VRF 2-way ME1 series 4 systems,
VRF 3-way 12 systems
Indoor Units: 171 units
Cooling Capacity:
592 kW / 168.33 USRT

Russia River Park Hotel



Air Conditioning System:
VRF 2-way ME1 series 47 systems
Indoor Units: 96 units
Cooling Capacity: 788 kW / 224 USRT

Germany The LEGOLAND Castle Hotel



Air Conditioning System:
VRF 3-way MF2 12 systems
Indoor Units: 144 units
Cooling Capacity:
592 kW / 168.33 USRT

OFFICE

Malaysia Gapruna project



Air Conditioning System:
VRF 2-way FSV ME1 series 109 systems
Indoor Units: 537 units
Cooling Capacity:
5,370 kW / 1,526 USRT

Malaysia Plaza 33 Office Block A



Air Conditioning System:
VRF 2-way FSV ME1 series 99 systems
Indoor Units: 153 units
Cooling Capacity:
3,667 kW / 1,042 USRT

Thailand Areeya



Air Conditioning System:
VRF 2-way FSV ME1 series 19 systems
Single split system 67 systems
Indoor Units: 85 units
Cooling Capacity:
1,519 kW / 432 USRT

HongKong King Yip Road



Air Conditioning System:
VRF FSM LA1 series 136 systems
Indoor Units: 294 units
Cooling Capacity:
2,108 kW / 599 USRT

England Soapworks



Air Conditioning System:
VRF 3-way MF2 77 systems
with ERV 167 systems

Spain PTA Malaga



Air Conditioning System:
VRF 2-way ME1 series 20 systems
Indoor Units: 74 units
Cooling Capacity:
908 kW / 258 USRT

Russia Russian Government Building



Air Conditioning System:
VRF 2-way ME1 series 42 systems
Indoor Units: 277 units
Cooling Capacity:
2,045 kW / 581 USRT

RETAIL

Italy Le Centurie CENTRO COMMERCIALE



Air Conditioning System:
VRF 3-way ME1 series 18 systems
Indoor Units: 57 units
Cooling Capacity:
656 kW / 186 USRT

India Sai Aarav Motors, Mehsana



Air Conditioning System:
VRF 2-way FSV ME1 series 3 systems
Indoor Units: 19 units
Cooling Capacity: 156 kW / 44 USRT

Russia Sun City Mall



Air Conditioning System:
VRF 2-way ME1 series 47 systems,
VRF 3-way 12 systems
Indoor Units: 283 units
Cooling Capacity:
1,605 kW / 456 USRT

SCHOOL

United States Shippensburg University



Air Conditioning System:
VRF 3-Way MF1 series 55 systems
Indoor Units: 530 units
Cooling Capacity:
1,498 kW / 426 USRT

SCHOOL

Malaysia Xiamen University



Air Conditioning System:
VRF FSV Systems 110 systems
Indoor Units: 1,349 units
Cloud adapter: CZ-CFUSCC1 17 pcs

Russia Technopark of Nobosibirsk Academgorodok



Air Conditioning System:
VRF 2-way ME1 series 38 systems,
VRF 3-way 12 systems
Indoor Units: 234 units
Cooling Capacity:
1,487 kW / 422 USRT

HOSPITAL

Indonesia Bekasi Hospital



Air Conditioning System:
VRF 2-way FSV ME1 series 42 systems
Indoor Units: 283 units
Cooling Capacity:
1,834 kW / 524 USRT

Indonesia Persada Hospital



Air Conditioning System:
VRF 2-way FSV ME1 series 21 systems
Indoor Units: 116 units
Cooling Capacity:
989 kW / 281 USRT

RESIDENTIAL

China Star River Group Luxury Condominium



Air Conditioning System:
VRF Master series 966 systems
Indoor Units: 3,948 systems
Cooling Capacity:
16,737 kW / 4,755 USRT

Singapore Punggol Eco-Town



Air Conditioning System:
Inverter multi-split room air conditioner
Indoor Units:
Wall mounted S Series (with ECOWALL)
Control System: Panasonic HEMS

Hong Kong Gloucester Road Project



Air Conditioning System:
VRF FSM LA1 series 67 systems
Twenty series 105 systems
Indoor Units: 255 units
Cooling Capacity: 1,391 kW / 395 USRT

Hong Kong The Green Project



Air Conditioning System:
VRF FSM LA1 series 239 systems
Twenty series 538 systems
Indoor Units: 999 units
Cooling Capacity:
6,425 kW / 1,825 USRT

India Royal Orchids Eco-Green Homz



Air Conditioning System:
VRF 2-way FSV ME1 series 22 systems,
Indoor Units: 139 units
Cooling Capacity:
802 kW / 228 USRT

India Heera Windfaire



Air Conditioning System:
VRF 2-way FSV ME1 series 96 systems,
VRF 3-way 12 systems
Indoor Units: 479 units
Cooling Capacity: 2,184kW / 620 USRT

Panama Mosaic Building PANAMA PACIFICO



Air Conditioning System:
VRF 2-way FSV LE1 series 156 systems
Indoor Units: 357 units
Cooling Capacity: 2,338 kW / 664 USRT